

ABB drives for HVAC

Hardware manual

ACH580-04 drive modules (250 to 500 kW)



Power and productivity
for a better world™



List of related manuals

Drive hardware manuals and guides	Code (English)	Code (Chinese)
<i>ACH580-04 drive modules (250 to 500 kW) hardware manual</i>	3AXD50000048685	
<i>ACH580-04 drive modules (250 to 500 kW) quick installation guide</i>	3AXD50000048686	3AXD50000048686
<i>ACS-AP-x Assistant control panels user's manual</i>	3AUA0000085685	
Drive firmware manuals		
<i>ACH580 HVAC control program firmware manual</i>	3AXD50000027537	
<i>ACH580 drives with HVAC control program quick start-up guide</i>	3AXD50000047658	
Option manuals and guides		
<i>DPMP-02/03 mounting platform for control panels installation guide</i>	3AUA0000136205	
<i>Manuals and quick guides for I/O extension modules, fieldbus adapters, etc.</i>		
<i>CCA-01 communication adapter quick guide</i>	3AXD50000018457	
<i>FBIP-21 BACnet/IP adapter module user's manual</i>	3AXD50000028468	
<i>FCAN-01 CANopen adapter module user's manual</i>	3AFE68615500	
<i>FCNA-01 ControlNet adapter module user's manual</i>	3AUA0000141650	
<i>FDNA-01 DeviceNet™ adapter module user's manual</i>	3AFE68573360	
<i>FECA-01 EtherCAT adapter module user's manual</i>	3AUA0000068940	
<i>FENA-01/-11/-21 Ethernet adapter module user's manual</i>	3AUA0000093568	
<i>FLON-01 LonWorks® adapter module user's manual</i>	3AUA0000041017	
<i>FEPL-02 Ethernet POWERLINK adapter module user's manual</i>	3AUA0000123527	
<i>FPBA-01 PROFIBUS DP adapter module user's manual</i>	3AFE68573271	
<i>FSCA-01 RS-485 adapter module user's manual</i>	3AUA0000109533	
<i>FOCH du/dt filters hardware manual</i>	3AFE68577519	
Tool and maintenance manuals and guides		
<i>Drive composer PC tool user's manual</i>	3AUA0000094606	
<i>Converter module capacitor reforming instructions</i>	3BFE64059629	
<i>NETA-21 remote monitoring tool user's manual</i>	3AUA0000096939	
<i>NETA-21 remote monitoring tool installation and startup guide</i>	3AUA0000096881	

You can find manuals and other product documents in PDF format on the Internet. See section [Document library on the Internet](#) on the inside of the back cover. For manuals not available in the Document library, contact your local ABB representative.

The QR code below opens an online listing of the manuals applicable to this product..



[ACH580-04 manuals](#)

Hardware manual

ACH580-04 drive modules
(250 to 500 kW)

Table of contents



1. Safety instructions



6. Installation instructions



9. Start-up



Table of contents

List of related manuals	2
1. Safety instructions	
Contents of this chapter	13
Use of warnings and notes	13
General safety in installation, start-up and maintenance	14
Electrical safety in installation, start-up and maintenance	16
Precautions before electrical work	16
Additional instructions and notes	17
Grounding	18
Additional instructions for permanent magnet motor drives	19
Safety in installation, start-up and maintenance	19
2. Introduction to the manual	
Contents of this chapter	21
Target audience	21
Contents of the manual	22
Categorization by frame size and option code	23
Quick installation, commissioning and operating flowchart	23
Terms and abbreviations	25
3. Operation principle and hardware description	
Contents of this chapter	27
Product overview	27
Layout	28
Drive module configuration with option +B051	29
Control panel	31
Overview of power and control connections	32
Control connection terminals	33
Type designation label	34
Type designation key	34
4. Guidelines for planning the cabinet installation	
Contents of this chapter	37
Limitation of liability	37
Installation positions of the drive module	37
Basic requirements for the cabinet	37
Planning the layout of the cabinet	38
Layout example, door closed	38
Layout example, door open (standard drive module configuration)	39
Layout example, door open (option +B051)	40
Arranging the grounding inside the cabinet	41
Selecting the busbar material and preparation of the joints	41
Tightening torques	41
Planning the fastening of the cabinet	41
Planning the cabinet placement on a cable channel	42



Planning the electromagnetic compatibility (EMC) of the cabinet	42
Planning the cooling	44
Preventing the recirculation of hot air	45
Standard drive module configuration	46
Drive module with option +B051	48
Required free space	49
Free space at the top of the drive module	49
Free space around the drive module	49
Other installation positions	49
Drive module on its back	49
Planning the placement of the control panel	50
Planning the use of cubicle heaters	50
Arc welding	50

5. Guidelines for planning the electrical installation

Contents of this chapter	51
Selecting the supply disconnecting device	52
European Union	52
Other regions	52
Selecting the main contactor	52
Examining the compatibility of the motor and drive	52
Protecting the motor insulation and bearings	52
Requirements table	53
Additional requirements for ABB motors of types other than M2_, M3_, M4_, HX_ and AM_	54
Additional requirements for ABB high-output and IP23 motors	54
Additional requirements for non-ABB high-output and IP23 motors	54
Additional data for calculating the rise time and the peak line-to-line voltage	55
Additional note for common mode filters	55
Selecting the power cables	55
General rules	55
Sufficient conductivity of the protective conductor	56
Typical power cable sizes	56
Alternative power cable types	58
Recommended power cable types	58
Power cable types for restricted use	58
Not allowed power cable types	58
Motor cable shield	58
Selecting the control cables	59
Shielding	59
Signals in separate cables	59
Signals allowed to be run in the same cable	59
Relay cable type	59
Control panel cable length and type	59
Routing the cables	60
Separate control cable ducts	60
Continuous motor cable shield or enclosure for equipment in the motor cable	61
Implementing thermal overload and short-circuit protection	61
Protecting the drive and input power cable in short-circuits	61
Protecting the motor and motor cable in short-circuits	61
Protecting the drive and the input power and motor cables against thermal overload	62
Protecting the motor against thermal overload	62



Protecting the drive against ground faults	62
Residual current device compatibility	62
Implementing the Emergency stop function	63
Implementing the Safe torque off function	63
Implementing the Power loss ride-through function	63
Using power factor compensation capacitors with the drive	63
Implementing a safety switch between the drive and the motor	63
Using a contactor between the drive and the motor	64
Implementing a bypass connection	64
Example bypass connection	65
Switching the motor power supply from drive to direct-on-line	65
Switching the motor power supply from direct-on-line to drive	66
Protecting the contacts of relay outputs	66
Connecting a motor temperature sensor to the drive I/O	67
Example circuit diagram	67

6. Installation instructions

Contents of this chapter	69
Safety	69
Checking the installation site	69
Moving and unpacking the unit	70
Checking the delivery	74
Installing the motor cable at the motor end	74
Checking the insulation of the assembly	75
Drive	75
Input cable	75
Motor and motor cable	75
Installation alternatives	75
Standard drive module configuration and option +B051	75
Optional input power cable connection terminals and ground busbar assembly (+H370)	75
Drive module without output cable connection terminals (option +0H371)	76
Drive module without pedestal (option +0H354)	76
Attaching the drive module to a mounting plate or wall	77
Alternatives for grounding the drive module	77
Installing the bottom grille (for IP20 degree protection)	78
Connecting the power cables	79
Connection diagram	79
Power cable connection procedure	80
DC connection	81
Connecting the control cables	82
Default I/O connection diagram (ABB standard macro)	84
Switches	85
PNP configuration for digital inputs (X2 & X3)	85
NPN configuration for digital inputs (X2 & X3)	86
Connection for obtaining 0...10 V from analog output 2 (AO2)	86
Connection examples of two-wire and three-wire sensors to analog input (AI2)	87
DI6 as frequency input	87
DI6 as PTC input	87
AI1 and AI2 as Pt100, Pt1000, Ni1000, KTY83 and KTY84 sensor inputs (X1)	88
Safe torque off (X4)	88
Connecting a control panel	88



Installing option modules	89
Option slot 2 (I/O extension modules)	89
Option slot 1 (fieldbus adapter modules)	89
Wiring the optional modules	89
Connecting a PC	90

7. Installation example of drive module with IP20 shrouds (option +B051)

Contents of this chapter	91
Limitation of liability	91
Safety	91
Required parts	92
Required tools	92
Overall flowchart of the installation process	92
Installing the drive module into a cabinet	93
Connecting the power cables and installing the shrouds	93
Installing the roof and door	95
Miscellaneous	96
Input power cable lead-through from top	96
Attaching the drive module to a mounting plate	96
IP20 shrouds	96

8. Installation checklist

Contents of this chapter	97
Installation checklist	97

9. Start-up

Contents of this chapter	101
Start-up procedure	101

10. Fault tracing

Contents of this chapter	103
Warning and fault messages	103

11. Maintenance

Contents of this chapter	105
Maintenance intervals	105
Descriptions of symbols	106
Recommended annual maintenance actions by the user	106
Recommended maintenance intervals after start-up	106
Cabinet	106
Cleaning the interior of the cabinet	106
Heatsink	107
Cleaning the interior of the heatsink	107
Fans	108
Replacing the circuit board compartment cooling fan	108
Replacing the main cooling fans	109
Replacing the drive module	110
Capacitors	111
Reforming the capacitors	111



Control panel	112
Cleaning the control panel	112
Replacing the battery in the assistant control panel	112

12. Technical data

Contents of this chapter	115
Ratings	115
IEC ratings	115
NEMA ratings	116
Output derating	116
Ambient temperature derating	117
Altitude derating	117
Deratings for special settings in the drive control program	117
Fuses (IEC)	118
Ultraprapid (aR) fuses	118
Fuses (UL)	118
Dimensions, weights and free space requirements	119
Losses, cooling data and noise	119
Terminal and lead-through data for the power cables	119
Drive modules without output cable connection terminals (+0H371) and with a common mode filter (+E208)	119
Terminal data for the control cables	119
Electrical power network specification	120
Motor connection data	120
DC connection data	120
Control unit (CCU-24) connection data	120
Control panel type	122
Efficiency	122
Degree of protection	122
Ambient conditions	123
CE marking	124
Compliance with the European Low Voltage Directive	124
Materials	124
Applicable standards	124
Compliance with the European EMC Directive	125
Compliance with the European RoHS Directive	125
Compliance with the European Machinery Directive	125
Compliance with EN 61800-3:2004	125
Definitions	125
Category C3	126
Category C4	126
UL marking	127
China RoHS marking	127
WEEE marking	128
EAC (Eurasian Conformity) marking	128
Cybersecurity disclaimer	128
Disclaimer	128

13. Dimension drawings

Contents of this chapter	129
R10 standard configuration	130
R10 with options +E208+0H354+H356+0H370+0H371	131



R10 with option +B051	132
R11 standard configuration	133
R11 with options +E208+0H354+H356+0H370+0H371	134
R11 with option +B051	135
Air baffles for the drive module with option +B051	136

14. Example circuit diagram

Contents of this chapter	137
Example circuit diagram	138

15. Safe torque off function

Contents of this chapter	139
Description	139
Compliance with the European Machinery Directive	140
Wiring	140
Activation switch	140
Cable types and lengths	141
Grounding of protective shields	141
Single drive (internal power supply)	141
Single drive (external +24 V DC power supply)	142
Dual-channel connection	142
Single-channel connection	143
Wiring examples	143
Multiple drives (internal power supply)	145
Multiple drives (external power supply)	146
Operation principle	147
Start-up including acceptance test	147
Competence	147
Acceptance test reports	147
Acceptance test procedure	147
Use	148
Maintenance	149
Competence	150
Fault tracing	150
Safety data	150
Abbreviations	151
Declaration of conformity	152

16. Optional I/O extension modules

Contents of this chapter	153
CHDI-01 115/230 V digital input extension module	153
Safety instructions	153
Hardware description	153
Product overview	153
Layout	154
Mechanical installation	154
Necessary tools and instructions	154
Unpacking and checking the delivery	154
Installing the module	154
Electrical installation	155
Warnings	155



Necessary tools and instructions	155
Terminal designations	155
General cabling instructions	155
Wiring	155
Start-up	156
Setting the parameters	156
Diagnostics	156
Faults and warning messages	156
LEDs	157
Technical data	157
Dimension drawing:	157
CMOD-01 multifunction extension module (external 24 V AC/DC and digital I/O)	159
Safety instructions	159
Hardware description	159
Product overview	159
Layout	160
Mechanical installation	160
Necessary tools and instructions	160
Unpacking and checking the delivery	160
Installing the module	160
Electrical installation	161
Warnings	161
Necessary tools and instructions	161
Terminal designations	161
General cabling instructions	161
Wiring	161
Start-up	163
Setting the parameters	163
Diagnostics	163
Faults and warning messages	163
LEDs	164
Technical data	164
Dimension drawing:	164
CMOD-02 multifunction extension module (external 24 V AC/DC and isolated PTC interface)	166
Safety instructions	166
Hardware description	166
Product overview	166
Layout	167
Mechanical installation	167
Necessary tools and instructions	167
Unpacking and checking the delivery	167
Installing the module	167
Electrical installation	168
Warnings	168
Necessary tools and instructions	168
Terminal designations	168
General cabling instructions	168
Wiring	168
Start-up	169
Setting the parameters	169
Diagnostics	170
Faults and warning messages	170
LEDs	170



Technical data	170
CPTC-02 ATEX-certified thermistor protection module, (external 24 V AC/DC and isolated PTC interface)	172

17. du/dt filters

Contents of this chapter	173
du/dt filters	173
When is du/dt filter needed?	173
Selection table	173
Ordering codes	173
Description, installation and technical data of the FOCH filters	173

18. Step-by-step drawings for an installation example of drive module with options +B051 and +E208 in Rittal TS 8 600 mm wide cabinet

Further information

Product and service inquiries	179
Product training	179
Providing feedback on ABB manuals	179
Document library on the Internet	179



1

Safety instructions



Contents of this chapter

This chapter contains the safety instructions which you must obey when you install and operate the drive and do maintenance on the drive. If you ignore the safety instructions, injury, death or damage can occur.

Use of warnings and notes

Warnings tell you about conditions which can cause injury or death, or damage to the equipment. They also tell you how to prevent the danger. Notes draw attention to a particular condition or fact, or give information on a subject.

The manual uses these warning symbols:



Electricity warning tells about hazards from electricity which can cause injury or death, or damage to the equipment.



General warning tells about conditions, other than those caused by electricity, which can cause injury or death, or damage to the equipment.



Electrostatic sensitive devices warning tells you about the risk of electrostatic discharge which can cause damage to the equipment.

General safety in installation, start-up and maintenance

These instructions are for all personnel that install the drive module and do maintenance work on it.



WARNING! Obey these instructions. If you ignore them, injury or death, or damage to the equipment can occur.

- Use protective gloves when working on the drive module.
- Handle the drive module carefully:
 - Use safety shoes with a metal toe cap to prevent foot injury.
 - Lift the drive module only by the lifting lugs.

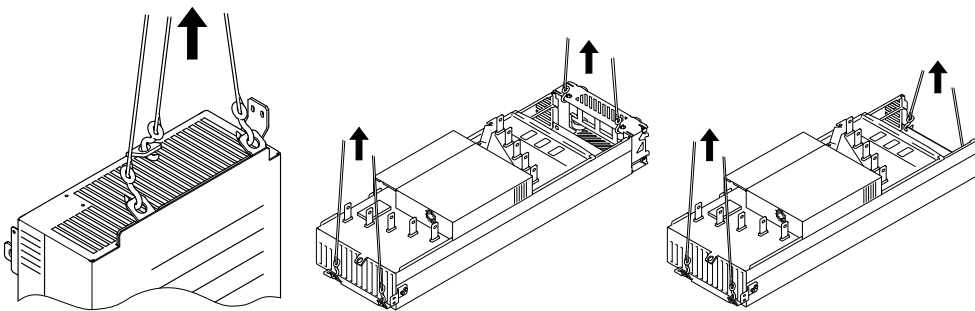

- Make sure that the module does not topple over when you move it on the floor: Open the support legs by pressing each leg a little down (1, 2) and turning it aside. Whenever possible secure the module also with chains.
- Do not tilt the drive module (A). It is **heavy** and its **center of gravity is high**. The module overturns from a sideways tilt of 5 degrees. Do not leave the module unattended on a sloping floor.

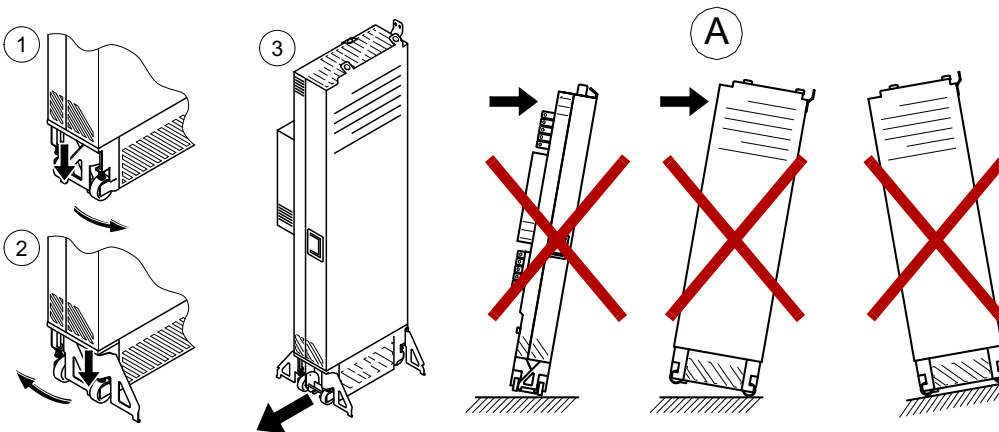

3AJUA0000086323

- Do not use the module installation ramp with plinth heights which exceed the maximum height marked on the ramp. (The maximum plinth height is 50 mm [1.97 in] when the telescopic ramp is fully retracted and 150 mm [5.91 in] when the ramp is fully extended.)
- Attach the module installation ramp carefully.

- To prevent the drive module from falling, attach its top lifting lugs with chains to the cabinet frame before you push the module into the cabinet and pull it from the cabinet. Work carefully preferably with help from another person as shown below. Keep a constant pressure with one foot on the base of the module to prevent the module from falling on its back

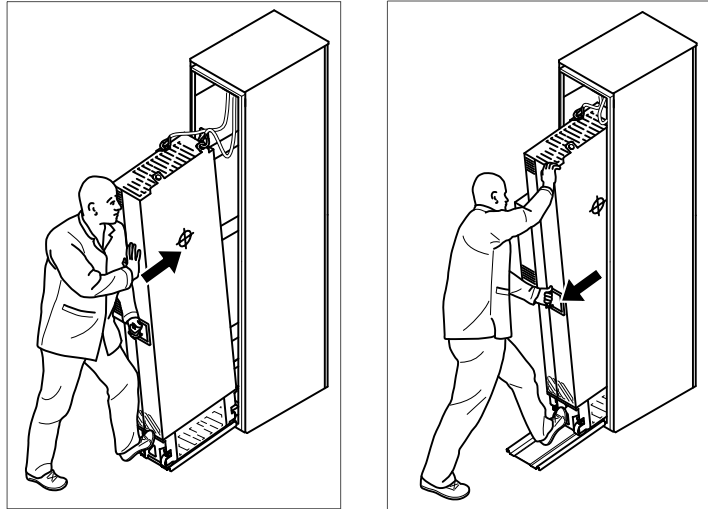

3AUA0000088632

- Beware of hot surfaces. Some parts, such as heatsinks of power semiconductors, remain hot for a while after disconnection of the electrical supply.
- Make sure that debris from borings and grindings does not enter the drive during the installation. Electrically conductive debris inside the drive may cause damage or malfunction.
- Make sure that there is sufficient cooling.
- Before you connect voltage to the drive, make sure that the cabinet doors are closed. Keep the doors closed during the operation. Obey the panel builder's instructions.
- Before you adjust the drive operation limits, make sure that the motor and all driven equipment can operate throughout the set operation limits.
- Before you activate the automatic fault reset or automatic restart functions of the drive control program, make sure that no dangerous situations can occur. These functions reset the drive automatically and continue operation after a fault or supply break. If these functions are activated, the installation must be clearly marked as defined in IEC/EN 61800-5-1, subclause 6.5.3, for example, "THIS MACHINE STARTS AUTOMATICALLY".
- The maximum number of drive power-ups is five in ten minutes. Too frequent power-ups can damage the charging circuit of the DC capacitors.
- Make sure that any safety circuits (for example, emergency stop and Safe torque off) are validated in start-up. See chapter [Start-up](#) for reference of the validation instructions.

Note:

- If you select an external source for start command and it is on, the drive will start immediately after fault reset unless you configure the drive for pulse start. See the firmware manual.
- When the control location is not set to Local, the stop key on the control panel will not stop the drive.



Electrical safety in installation, start-up and maintenance

■ Precautions before electrical work

These warnings are for all personnel that do work on the drive, motor cable or motor.



WARNING! Obey these instructions. If you ignore them, injury or death, or damage to the equipment can occur. If you are not a qualified electrician, do not do installation or maintenance work. Go through these steps before you begin any installation or maintenance work.

1. Clearly identify the work location.
 2. Disconnect all possible voltage sources.
 - Open the main disconnecter of the drive.
 - Open the disconnecter of the supply transformer as the main disconnecter of the drive does not remove the voltage from the input busbars of the drive.
 - Make sure that reconnection is not possible. Lock the disconnectors to open position and attach a warning notice to them.
 - Disconnect any external power sources from the control circuits before you do work on the control cables.
 - After you disconnect the drive, always wait for 5 minutes to let the intermediate circuit capacitors discharge before you continue.
 3. Protect any other energized parts in the work location against contact.
 4. Take special precautions when close to bare conductors.
 5. Measure that the installation is de-energized.
 - Use a multimeter with an impedance of at least 1 Mohm.
 - Make sure that the voltage between the drive module input power terminals (L1/U1, L2/V1, L3/W1) and the grounding (PE) busbar is close to 0 V.
 - If the drive module is equipped with UDC+ and UDC- terminals (option +H356), make sure that the voltage between the UDC+ and UDC- terminals and the grounding (PE) busbar is close to 0 V.
 6. Install temporary grounding as required by the local regulations.
 7. Ask for a permit to work from the person in control of the electrical installation work.
-



■ Additional instructions and notes



WARNING! Obey these instructions. If you ignore them, injury or death, or damage to the equipment can occur.

- If you are not a qualified electrician, do not do installation or maintenance work.
- Do not install a drive with EMC filter option +E202 on an ungrounded power system or a high resistance-grounded (over 30 ohms) power system.
- Do not connect the drive to a voltage higher than what is on the type designation label. Overvoltage can cause the motor to rush to its maximum speed.
- We do not recommend that you secure the cabinet by arc welding. If you have to, obey the instructions in section [Arc welding](#) on page 50.
- Do not do insulation or voltage withstand tests on the drive or drive modules.

Note:

- The motor cable terminals of the drive are at a dangerous voltage when the input power is on, regardless of whether the motor is running or not.
- The DC bus terminals (UDC+, UDC-) are at a dangerous voltage.
- External wiring can supply dangerous voltages to the terminals of relay outputs (XRO1, XRO2 and XRO3).
- The Safe torque off function does not remove the voltage from the main and auxiliary circuits. The function is not effective against deliberate sabotage or misuse.



WARNING! Use a grounding wrist band when you handle the printed circuit boards. Do not touch the boards unnecessarily. The boards contain components sensitive to electrostatic discharge.



WARNING! Obey these instructions. If you ignore them, equipment malfunction and damage to the fiber optic cables can occur.

- Handle the fiber optic cables with care.
- When you unplug the cables, always hold the connector, not the cable itself.
- Do not touch the ends of the fibers with bare hands as the ends are extremely sensitive to dirt.
- Do not bend the fiber optic cables too tightly. The minimum allowed bend radius is 35 mm (1.4 in).



■ Grounding

These instructions are for all personnel who are responsible for the grounding of the drive.



WARNING! Obey these instructions. If you ignore them, injury or death, or equipment malfunction can occur, and electromagnetic interference can increase.

- If you are not a qualified electrician, do not do grounding work.
- Always ground the drive, the motor and adjoining equipment. This is necessary for the personnel safety. Proper grounding also reduces electromagnetic emission and interference.
- Make sure that the conductivity of the grounding conductors is sufficient. See section [Selecting the power cables](#) on page 55. Obey the local regulations.
- Connect the power cable shields to protective earth (PE) of the drive to make sure of personnel safety.
- Make a 360° grounding of the power and control cable shields at the cable entries to suppress electromagnetic disturbances.
- In a multiple-drive installation, connect each drive separately to the protective earth (PE) busbar of the switch board or the transformer.

Note:

- You can use power cable shields as grounding conductors only when their conductivity is sufficient.
 - As the normal touch current of the drive is higher than 3.5 mA AC or 10 mA DC, you must use a fixed protective earth connection. See standard EN 61800-5-1, 4.3.5.5.2.
-



Additional instructions for permanent magnet motor drives

■ Safety in installation, start-up and maintenance

These are additional warnings concerning permanent magnet motor drives. The other safety instructions in this chapter are also valid.



WARNING! Obey these instructions. If you ignore them, injury or death and equipment malfunction can occur.

- Do not do work on the drive when the permanent magnet motor is rotating. A rotating permanent magnet motor energizes the drive including its input power terminals.

Before installation, start-up and maintenance work on the drive:

- Stop the motor.
- Disconnect the motor from the drive with a safety switch or by other means.
- If you cannot disconnect the motor, make sure that the motor cannot rotate during work. Make sure that no other system, like hydraulic crawling drives, can rotate the motor directly or through any mechanical connection like felt, nip, rope, etc.
- Measure that the installation is de-energized.
 - Use a multimeter with an impedance of at least 1 Mohm.
 - Make sure that the voltage between the drive output terminals (T1/U2, T2/V2, T3/W2) and the grounding (PE) busbar is close to 0 V.
 - Make sure that the voltage between the drive input power terminals (L1/U1, L2/V1, L3/W1) and the grounding (PE) busbar is close to 0 V.
 - Make sure that the voltage between the drive module UDC+ and UDC- terminals and the grounding (PE) busbar is close to 0 V.
- Install temporary grounding to the drive output terminals (T1/U2, T2/V2, T3/W2). Connect the output terminals together as well as to the PE.
- Make sure that the operator cannot run the motor over the rated speed. Motor overspeed causes overvoltage can damage or explode the capacitors in the intermediate circuit of the drive.







Introduction to the manual

Contents of this chapter

This chapter describes the intended audience and contents of the manual. It contains a flowchart of steps in checking the delivery, installing and commissioning the drive. The flowchart refers to chapters/sections in this manual and other manuals.

Target audience

This manual is intended for persons who

- plan the cabinet assembly of the drive module and install the module into a user-defined cabinet
- plan the electrical installation of the drive cabinet
- make instructions for the end user of the drive concerning the mechanical installation of the drive cabinet, connection of power and control cables to the cabinet-installed drive and maintenance of the drive.

Read the manual before working on the drive. You are expected to know the fundamentals of electricity, wiring, electrical components and electrical schematic symbols.

The manual is written for readers worldwide. Both SI and imperial units are shown.

Contents of the manual

This manual contains the instructions and information for the basic drive module configuration. The chapters of the manual are briefly described below.

Safety instructions gives safety instructions for the installation, commissioning, operation and maintenance of the drive module.

Introduction to the manual introduces the manual.

Operation principle and hardware description describes the drive module.

Guidelines for planning the cabinet installation guides in planning drive cabinets and installing the drive module into a user-defined cabinet. The chapter gives cabinet layout examples and free space requirements around the module for cooling.

Guidelines for planning the electrical installation instructs in the motor and cable selection, protections and cable routing.

Installation instructions gives the basic installation instructions that are common for the different installation procedures.

Installation example of drive module with IP20 shrouds (option +B051) describes the installation process of a standard drive module in a Rittal 600 mm wide cabinet.

Installation checklist contains lists for checking the mechanical and electrical installation of the drive.

Start-up refers to the start-up instructions of the cabinet-installed drive.

Fault tracing describes the LED indications and refers to the fault tracing instructions of the drive.

Maintenance contains maintenance instructions.

Technical data contains the technical specifications of the drive module, eg, the ratings, sizes and technical requirements, provisions for fulfilling the requirements for CE and other markings.

Dimension drawings contains dimension drawings of the drive module installed into a Rittal TS 8 cabinet.

Example circuit diagram shows an example circuit diagram for a cabinet-installed drive module.

Safe torque off function describes the Safe torque off function of the drive and gives instructions on its implementing.

du/dt filters describes how to select du/dt filters for the drive.

Step-by-step drawings for an installation example of drive module with options +B051 and +E208 in Rittal TS 8 600 mm wide cabinet shows how to install the drive module in a Rittal TS 8 cabinet.

Categorization by frame size and option code

The instructions, technical data and dimension drawings which concern only certain drive frame sizes are marked with the symbol of the frame size (R10 or R11). The frame size is marked on the type designation label.

The instructions and technical data which concern only certain optional selections are marked with option codes, eg, +J410. The options included in the drive can be identified from the option codes visible on the type designation label. The option selections are listed in section [Type designation key](#) on page 34.

Quick installation, commissioning and operating flowchart

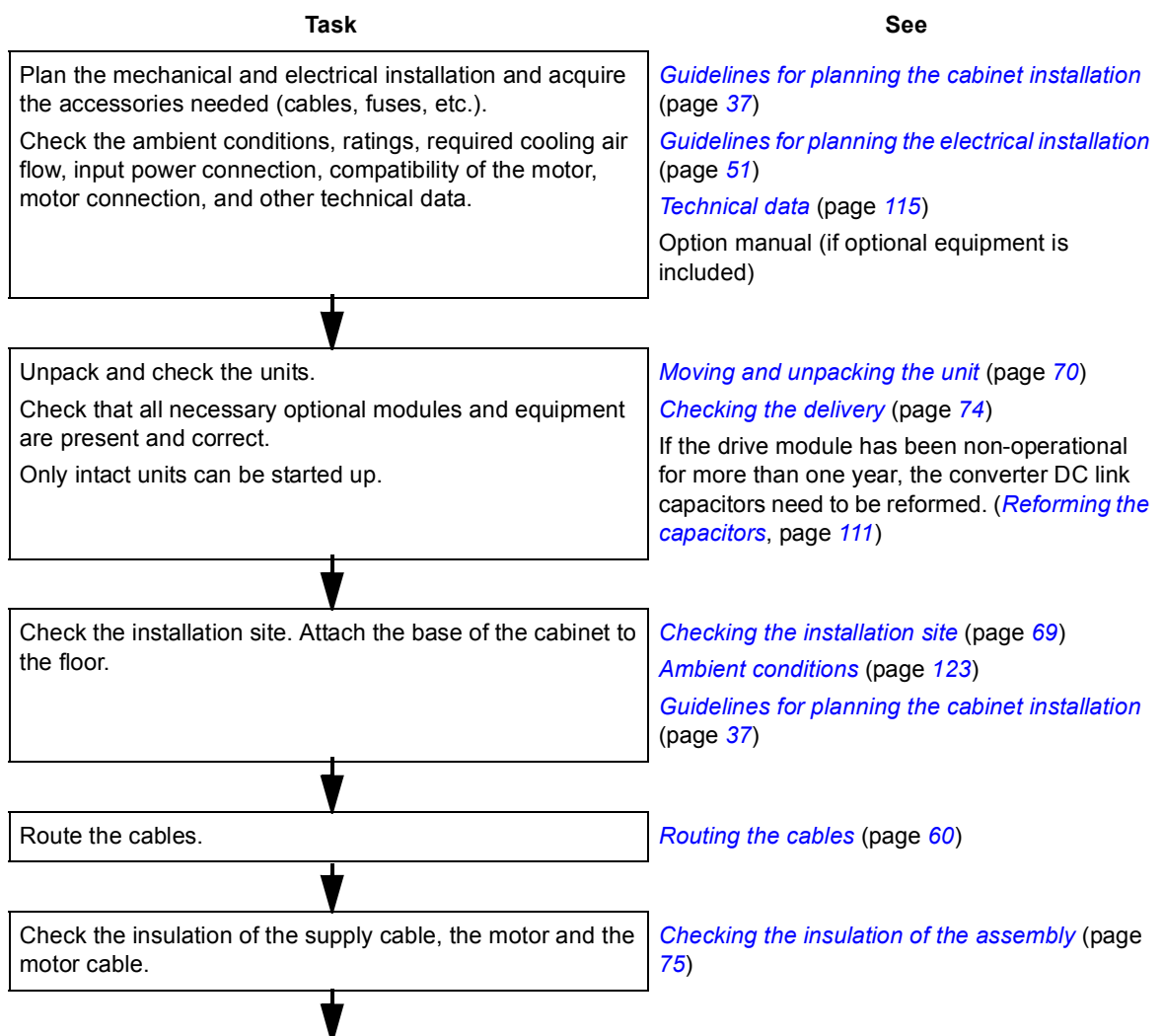

Task	See
<p><u>Standard drive modules</u></p> <ul style="list-style-type: none">• Install the additional components into the cabinet: for example, main disconnect, main contactor, main AC fuses, etc.• Install the drive module into the cabinet.• Connect the motor cables to the drive module terminals.• Connect the DC connection cables (if any) to the drive module terminals.• If the main disconnect is installed into the cabinet, connect it to the drive module terminals and the input power cabling to the disconnect.	<p>Installing the drive module into a cabinet (page 93)</p> <p>Connecting the power cables (page 79)</p> <p>Manuals for any optional equipment</p>
<p><u>Drive modules with IP20 shrouds (option +B051)</u></p>	<p>Step-by-step drawings for an installation example of drive module with options +B051 and +E208 in Rittal TS 8 600 mm wide cabinet (page 175)</p>
<p>Connect the external control cables to the drive control unit.</p>	<p>Connecting the control cables (page 82)</p>
<p>Check the installation.</p>	<p>Installation checklist (page 97)</p>
<p>Commission the drive.</p>	<p>Start-up (page 101)</p>
<p>Operate the drive: start, stop, speed control etc.</p>	<p>Firmware manual</p>

Terms and abbreviations

Term/Abbreviation	Explanation
ACS-AP-x	Assistant control panel, advanced operator keypad for communication with the drive. The ACH580 supports types ACH-AP-H and ACH-AP-W.
CCA-01	Optional communication adapter
CHDI-01	Optional 115/230 V digital input extension module
CMOD-01	Optional multifunction extension module (external 24 V AC/DC and digital I/O extension)
CMOD-02	Optional multifunction extension module (external 24 V AC/DC and isolated PTC interface)
CMF	Common mode filtering
EMC	Electromagnetic compatibility
EMI	Electromagnetic interference
FBIP-21	Optional BACnet/IP adapter module
FCAN-01	Optional CANopen adapter module
FCNA-01	Optional ControlNet fieldbus adapter module
FDNA-01	Optional DeviceNet™ fieldbus adapter module
FECA-01	Optional EtherCAT adapter module
FENA-11	Optional high performance Ethernet/IP™, Modbus/TCP and PROFINET IO adapter module
FENA-21	Optional 2-port Ethernet (EtherNet/IP, Modbus/TCP, PROFINET) adapter module
FEPL-02	Optional Ethernet POWERLINK fieldbus adapter module
FPBA-01	Optional PROFIBUS DP adapter module
Frame (size)	Size of the drive module. The drive modules described in this manual are of frame size R10 and R11.
FSCA-01	Optional Modbus RTU adapter module
IGBT	Insulated gate bipolar transistor; a voltage-controlled semiconductor type widely used in converters due to their easy controllability and high switching frequency.
I/O	Input/Output
IT system	Type of supply network that has no (low-impedance) connection to ground.
NETA-21	Remote monitoring tool
PLC	Programmable logic controller
RFI	Radio-frequency interference
STO	Safe torque off
TN system	Type of supply network that provides a direct connection to ground.

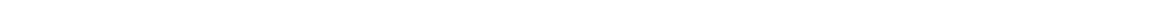

3

Operation principle and hardware description

Contents of this chapter

This chapter describes the operating principle and construction of the drive module.

Product overview

The ACH580-04 is a drive module for controlling AC induction motors, synchronous reluctance motors and synchronous permanent magnet motors in open loop control.

The main circuit of the drive module is shown below.

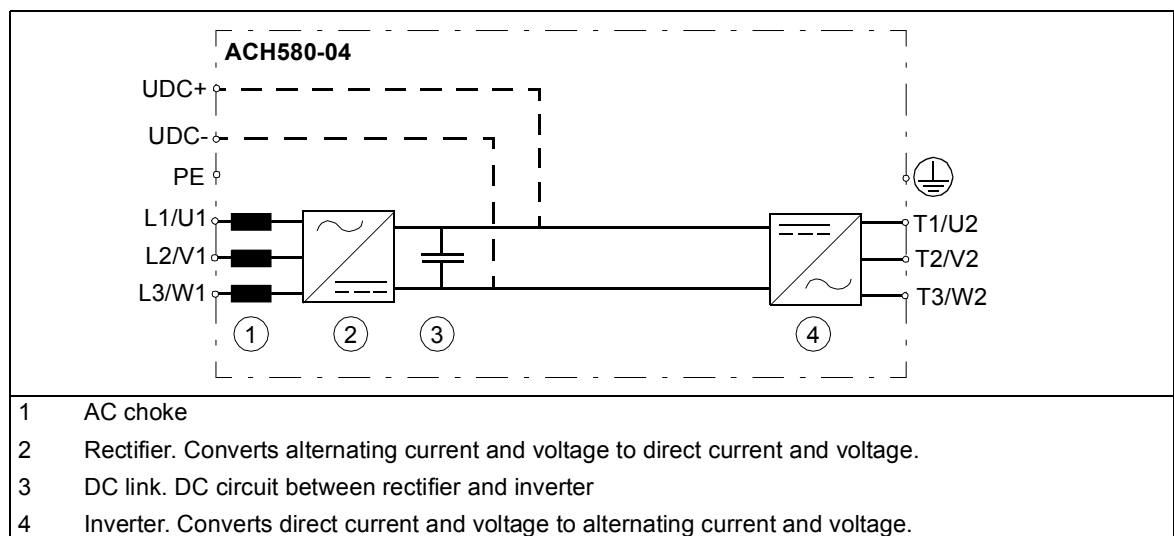

Layout

Standard drive module configuration

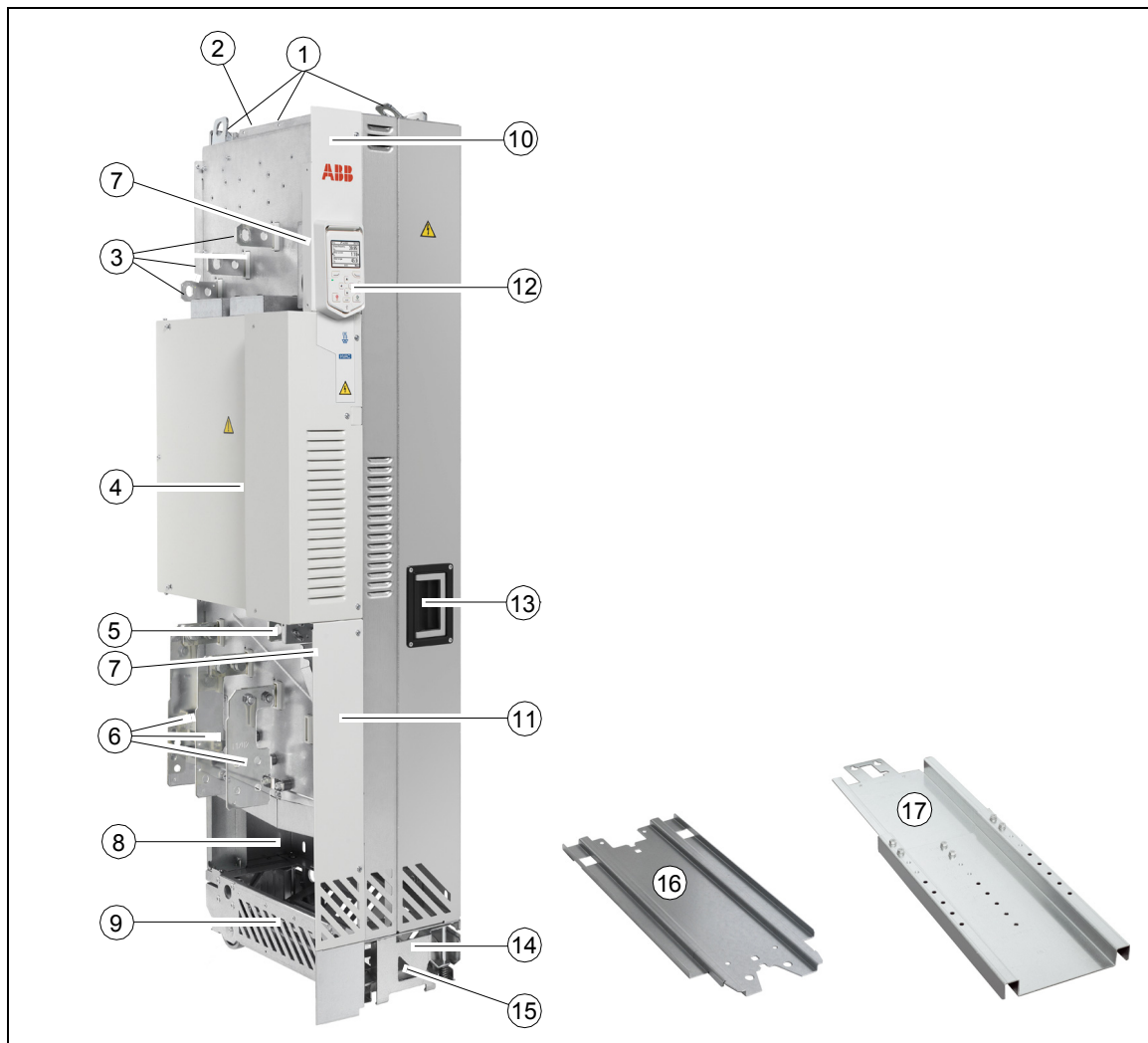

- | | |
|----|---|
| 1 | Lifting lugs |
| 2 | Fastening bracket |
| 3 | Input cable connection busbars (L1/U1, L2/V1, L3/W1) |
| 4 | Circuit board compartment |
| 5 | PE busbar |
| 6 | Output cable connection terminals (T1/U2, T2/V2, T3/W2) attached |
| 7 | Control cable duct |
| 8 | Main cooling fans |
| 9 | Pedestal |
| 10 | Upper front cover |
| 11 | Lower front cover |
| 12 | Control panel. Can also be mounted on the cabinet door as well with the door mounting platform kit. |
| 13 | Handle for pulling the drive module out of the cabinet |
| 14 | Retractable support legs |
| 15 | Base fastening screws behind the retractable support legs |
| 16 | Pedestal guide plate |
| 17 | Telescopic extraction and insertion ramp |

■ Drive module configuration with option +B051

The drive module configuration with clear plastic shrouds (option +B051) mounted is shown below.

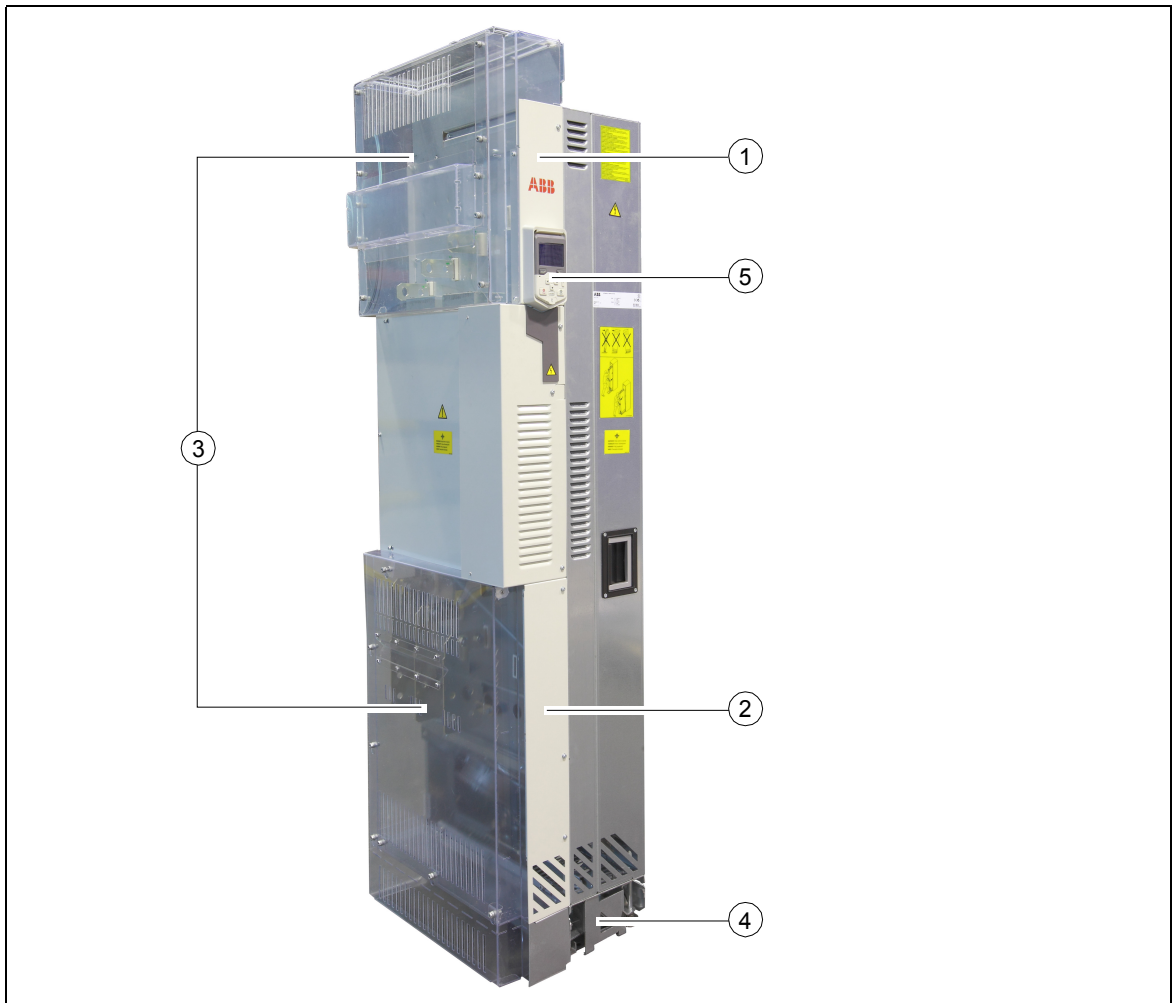

- | | | | |
|---|---|---|---------------|
| 1 | Upper front cover | 4 | Pedestal |
| 2 | Lower front cover | 5 | Control panel |
| 3 | Clear plastic shrouds attached (option +B051) | | |

See the next page for the part descriptions.

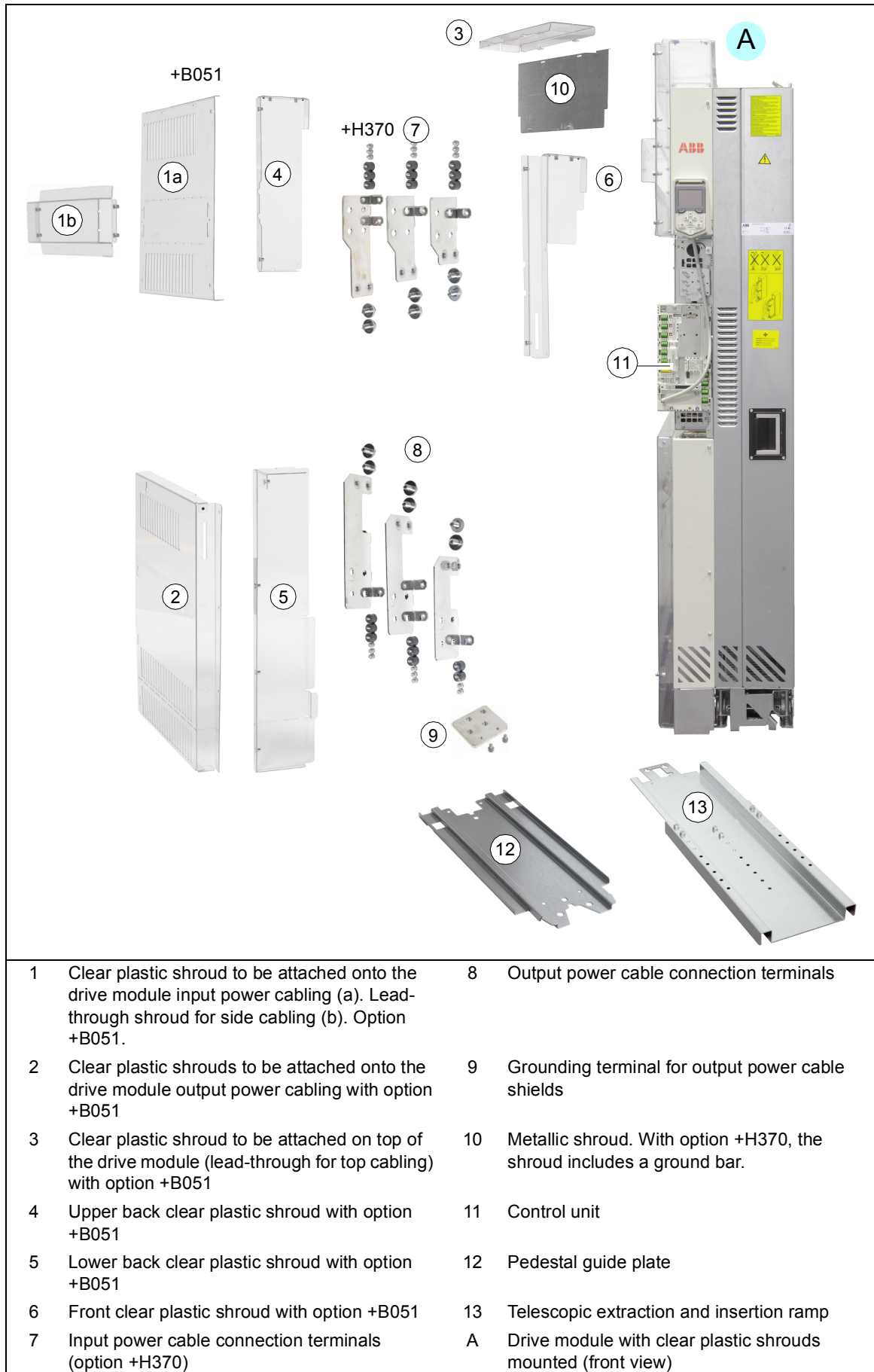

■ Control panel



- 1 ACH-AP-H hand-off-auto control panel (standard)
- 2 CDUM-01 blank control panel cover (no control panel) (option +J424)
- 3 ACH-AP-W hand-off-auto control panel with bluetooth interface (option +J429)
- 4 DPMP-03 control panel mounting platform

In the standard drive module configuration, the control panel is located on the internal control unit.

DPMP-03 door mounting platform is also available with option +J410 in the Chinese market. In other market regions, DPMP-03 kit is included in the standard delivery. DPMP-03 allows you to mount the control panel on the cabinet door.

For the use of the control panel, see the firmware manual or *ACS-AP-X assistant control panels user's manual* (3AUA0000085685 [English]).

Overview of power and control connections

The diagram shows the power connections and control interfaces of the drive module.

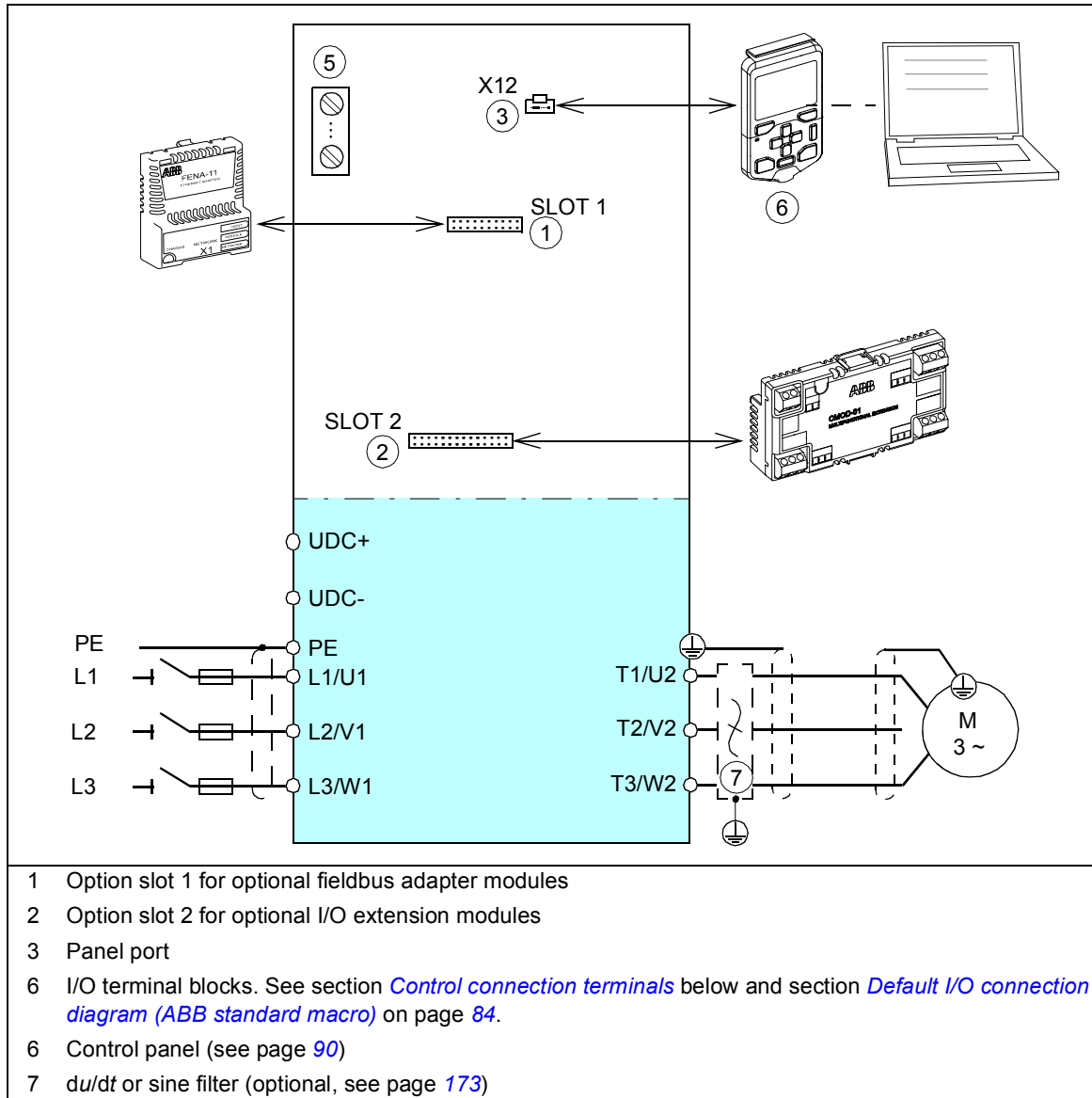







■ Control connection terminals

The layout of the control connection terminals on the drive module control are shown below.

SLOT 1	
Option slot 1 (fieldbus adapter modules)	
ANALOG IN/OUT	
1...3	Analog input 1
AI1	Current/Voltage selection switch for analog input 1
4...6	Analog input 2
AI2	Current/Voltage selection switch for analog input 2
7...9	Analog outputs
AO1	Current/Voltage selection switch for analog output 1
EIO	
10...12	Auxiliary voltage output
DIGITAL IN	
13...18	Digital inputs
STO	
34...38	Safe torque off connection
EIO	
FAN2	Internal fan 2 connection
FAN1	Internal fan 1 connection
X12	Panel port (control panel connection, wired at the factory to the control panel)
X15	Reserved for internal use
EFB	
EIA/R5-485 fieldbus connector	
BIAS S101	Bias resistor switch
TERM S100	End termination switch
29...31	Connection terminals
SLOT 2	
Option slot 2 (I/O extension modules)	
EIO	
40, 41	24 V AC/DC external power input
RO1 ... RO3	
19...21	Relay output 1 (RO1)
22...24	Relay output 2 (RO2)
25...27	Relay output 3 (RO3)

Type designation label

The type designation label includes a rating, markings, a type designation and a serial number, which allow individual recognition of each drive module. The type designation label is located on the front cover. An example label is shown below.

	① ACH580-04-585A-4+E208+E210+J400+J410	
MADE IN FINLAND	③	④ 
ABB Oy Hiomotie 13 00380 Helsinki Finland	Input U1 3~ 400/480 VAC I1 585/573 A f1 50/60 Hz	
FRAME	Output U2 3~ 0...U1 I2 585/573 A f2 0...500 Hz	 
R10		⑨  S/N: M170600002
Air cooling		
IP00 UL open type	Icc 100 kA	

1	Type designation, see section on page 40.
2	Manufacturer's address
3	Ratings, see section Ratings on page 115, Electrical power network specification on page 120 and Motor connection data on page 120.
4	Valid markings
5	Frame size
6	Cooling method
7	Degree of protection, enclosure type
8	Short-circuit withstand strength, see section Electrical power network specification on page 120.
9	Serial number. The first digit of the serial number refers to the manufacturing plant. The next four digits refer to the unit's manufacturing year and week, respectively. The remaining digits complete the serial number so that there are no two units with the same number.

Type designation key

The type designation contains information on the specifications and configuration of the drive module. The first digits from left express the basic configuration. The optional selections are given thereafter, separated by plus signs, eg, +J410. The main selections are described below. Not all selections are available for all types. For more information, refer to *ACH580-04 Ordering Information* (3AXD10000580721), available on request.

Code	Description
Basic code, eg, ACH580-04-585A-4	
Product series	
ACH580	ACH580 product series
Type	
-04	When no options are selected: drive module to be installed in a cabinet, IP00 (UL open type), bookshelf mounting with pedestal, internal control unit (inside the drive module), assistant control panel ACH-AP-H and panel holder, build-in choke, installation ramp, full-size output cable connection terminals, no EMC filter, no DC connection busbars, ACH580 HVAC standard control program, RS-485 Modbus RTU adapter module (CEIA-01), Safe torque off function, coated boards, printed multilingual quick installation guide.
Size	
xxxA	Refer to the rating tables, page 115.
Voltage range	
-4	380...480 V
Option codes (plus codes)	

Code	Description
Construction, pedestal and cabling	
B051	IP20 shrouds for cabling area
H370	Full-size input power cable connection terminals and PE busbar
Control panel and mounting platform	
J400	Hand-Off-Auto control panel (standard) ACH-AP-H
OJ400	No control panel. Note: You need at least one loose control panel to be able to commission the drive.
J424	Blank control panel cover (no control panel) CDUM-01
J429	Assistant control panel with bluetooth interface ACH-AP-W
Fieldbus adapter modules	
K451	FDNA-01 DeviceNet™ fieldbus adapter module
K452	LonWorks
K454	FPBA-01 PROFIBUS DP fieldbus adapter module
K457	FCAN-01 CANopen fieldbus adapter module
K458	FSCA-01 Modbus/RTU adapter module
K462	FCNA-01 ControlNet fieldbus adapter module
K465	BACnet/IP (2-port)
K469	FECA-01 EtherCAT® fieldbus adapter module
K470	FEPL-02 Ethernet POWERLINK fieldbus adapter module
K473	FENA-11 Ethernet/IP™, Modbus/TCP and PROFINET IO fieldbus adapter module
K475	2-port Ethernet (EtherNet/IP, Modbus/TCP, PROFINET)
I/O extension and feedback interface modules	
L501	CMOD-01 external 24 V DC/AC and digital I/O extension module (two relay outputs and one digital output)
L512	CHDI-01 115/230 V digital input module (six digital inputs and two relay outputs)
L523	CMOD-02 external 24 V and isolated PTC interface
Specialities	
P931	Extended warranty 36 extends the total warranty to 36 months from delivery.
P932	Extended warranty 60 extends the total warranty to 60 months from delivery.
Paper manuals. Note: The delivered manual set can include manuals in English if the translation is not available.	
R700	English
R701	German
R702	Italian
R703	Dutch
R704	Danish
R705	Swedish
R706	Finnish
R707	French
R708	Spanish
R709	Portuguese (in Brazilian Portuguese)
R711	Russian
R712	Chinese
R714	Turkish

4

Guidelines for planning the cabinet installation

Contents of this chapter

This chapter guides in planning drive cabinets and installing the drive module into a user-defined cabinet. The chapter gives cabinet layout examples and free space requirements around the module for cooling. These guidelines are essential for the safe and trouble-free use of the drive system.

Limitation of liability

You must always plan and make the installation according to applicable local laws and regulations. ABB does not assume any liability whatsoever for any installation which breaches the local laws and/or other regulations.

Installation positions of the drive module

You can put the drive module in the bookshelf position in a cabinet.

Basic requirements for the cabinet

Use a cabinet which

- has a frame sturdy enough to carry the weight of the drive components, control circuitry and other equipment installed in it
 - protects the user and drive module against contact and meets the requirements for dust and humidity
 - has sufficient air inlet and outlet gratings that allow free flow of cooling air through the cabinet. This is critical for proper cooling of the drive module.
-

Planning the layout of the cabinet

Plan a spacious layout to ensure easy installation and maintenance. Sufficient cooling air flow, obligatory clearances, cables and cable support structures all require space.

Place the control board(s) away from:

- main circuit components such as contactors, switches and power cables
- hot parts (heat sink, air outlet of the drive module).

Layout example, door closed

This diagram shows a cabinet layout example with the input power cable lead-through from top and the motor cable lead-through from bottom.

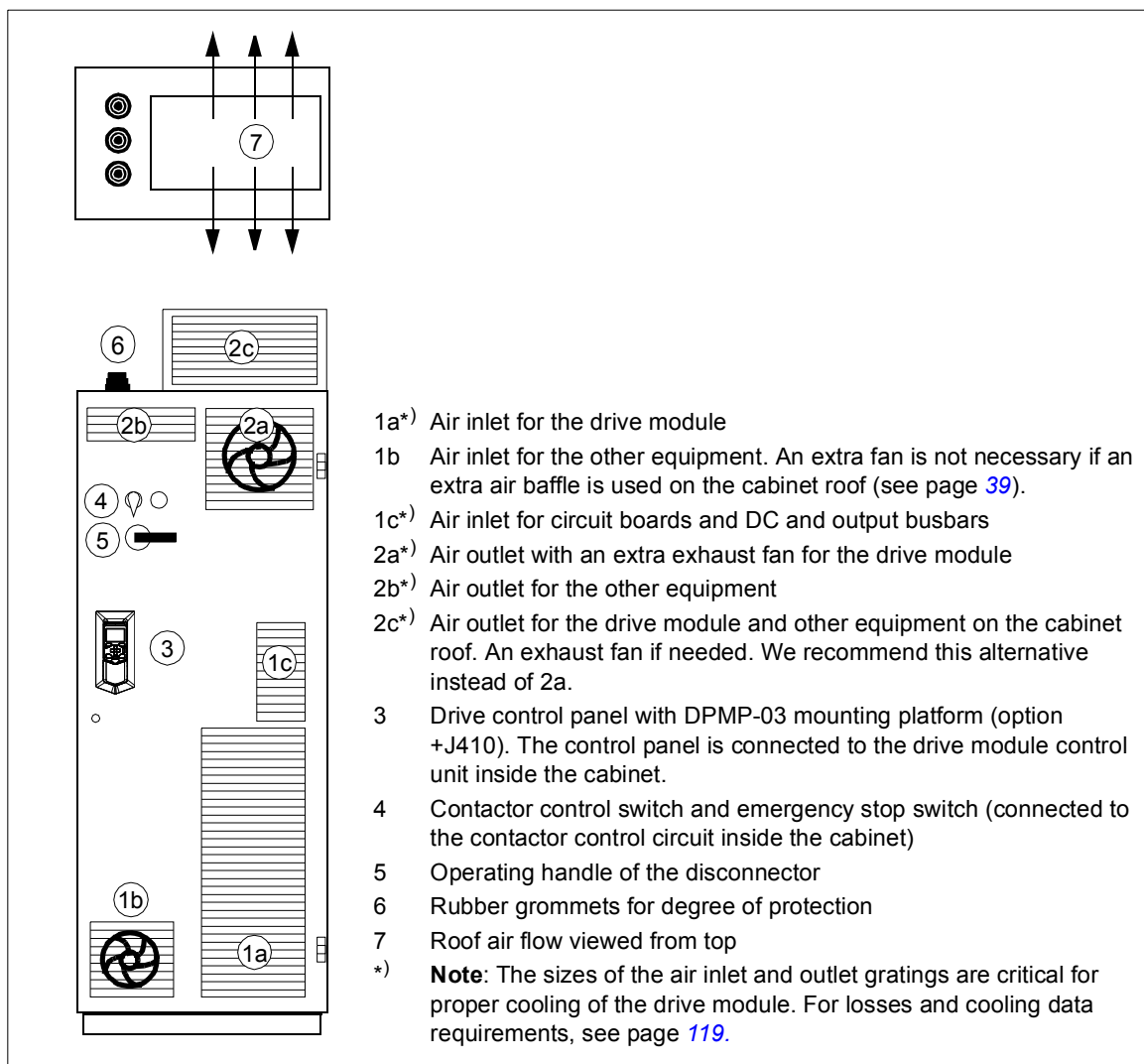

Layout example, door open (standard drive module configuration)

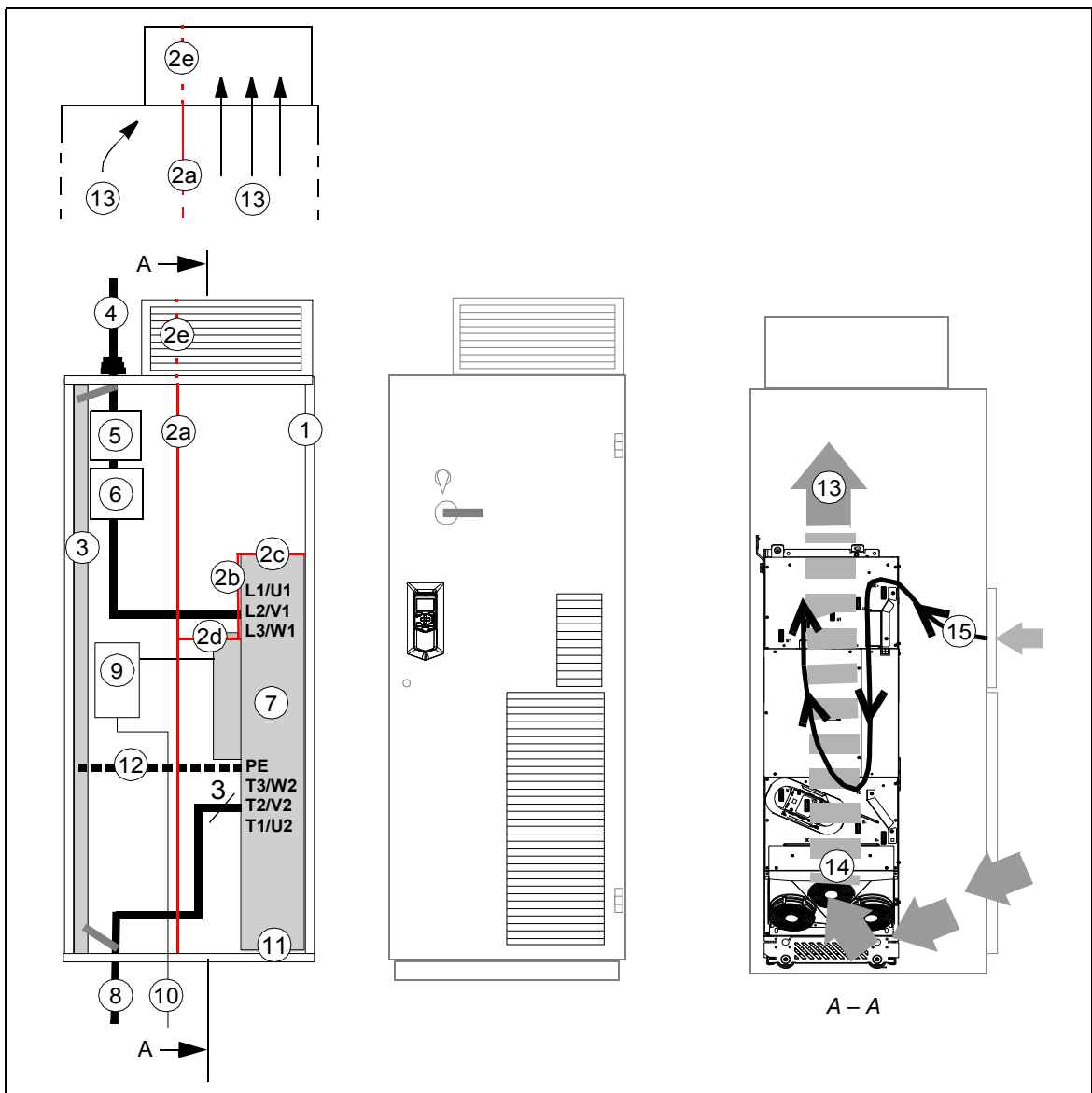

- | | |
|--|---|
| 1 Supporting frame of the cabinet | 8 Motor cable including the protective ground conductor of the drive module |
| 2 Vertical (2a, 2b) and horizontal (2c, 2d) air baffles that separate the cool and hot areas (leak-proof lead-throughs). See also page 45. | 9 Drive module control unit. Note: With the internal control unit, the upper door air inlet is critical for proper cooling of the control board. |
| 2e Optional air baffle that is needed when there is no fan on the lower part of the cabinet door (see 1b on page on 38) | 10 External control cables |
| 3 Cabinet grounding busbar (PE) | 11 Grounding screws |
| 4 Input power cable including the protective ground conductor (PE) of the drive | 12 Alternative to grounding screws (11) |
| 5 Disconnecter and fuses | 13 Air flow to the roof |
| 6 Contactor | 14 Air flow through the drive module |
| 7 Drive module | 15 Air flow through circuit boards and to DC output busbars |
| | - - |

Note 1: The power cable shields can also be grounded to the drive module grounding terminals.

Note 2: See also section *Required free space*, page 49.

■ **Layout example, door open (option +B051)**

This diagram shows a layout example for drive modules with IP20 shrouds (option +B051).

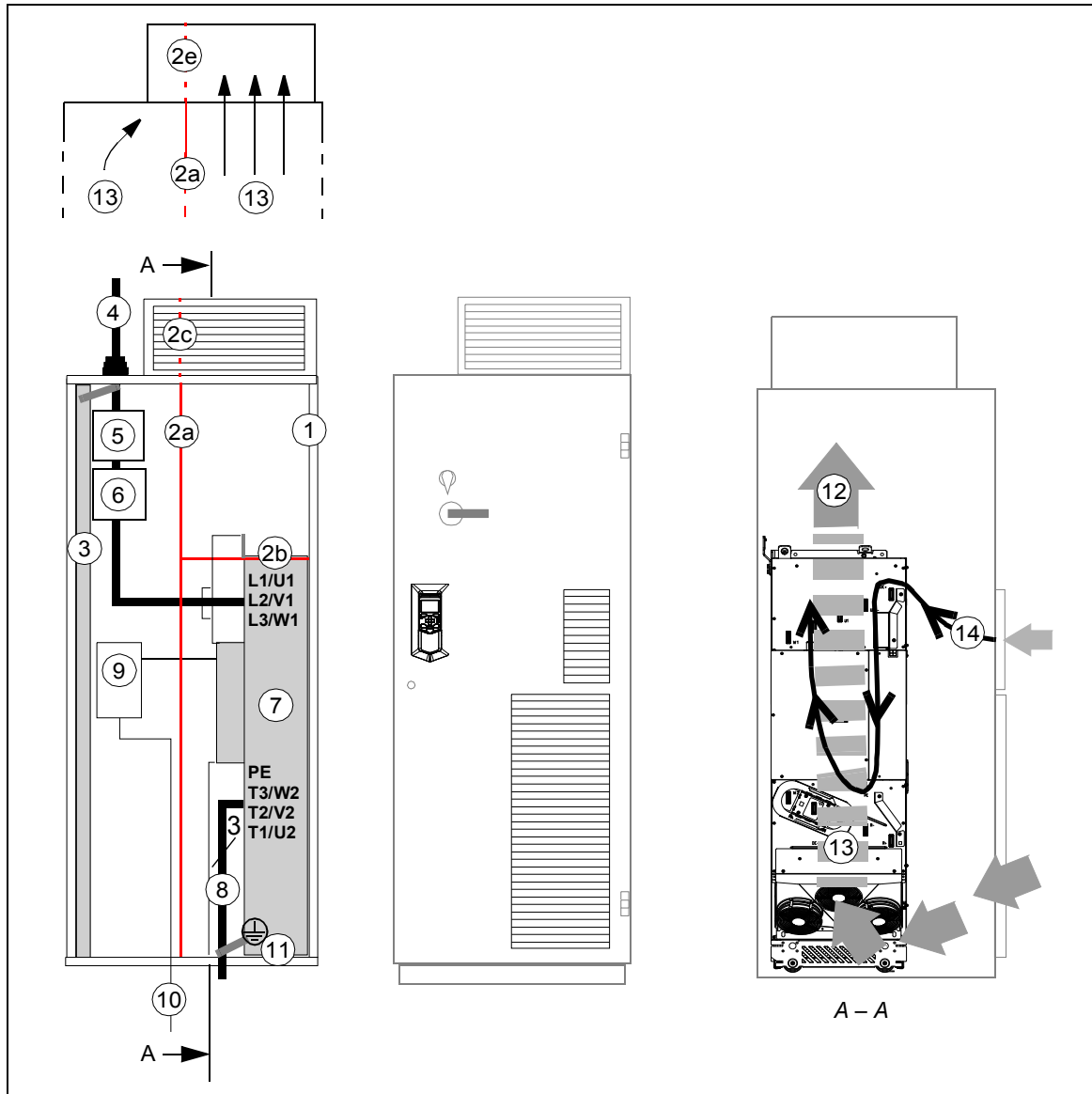

- | | |
|---|--|
| 1 Supporting frame of the cabinet | 7 Drive module |
| 2a Vertical (2a) and horizontal (2b) air baffles | 8 Motor cable including the protective ground conductor |
| 2b that separate the cool and hot areas (leak-proof lead-throughs). See also page 45. | of the drive module |
| 2c Optional air baffle that is needed when there is no fan on the lower part of the cabinet door (see 1b on page on 38) | 9 Drive module control unit. Note: With an internal control unit, the upper door air inlet is critical for proper cooling of the control board. |
| 3 Cabinet grounding busbar (PE) | 10 External control cables |
| 4 Input power cable including the protective ground conductor (PE) of the drive | 11 Grounding screws |
| 5 Disconnect and fuses | 12 Air flow to the roof |
| 6 Contactor | 13 Air flow through the drive module |
| | 14 Air flow through circuit boards and to DC output busbars |

Arranging the grounding inside the cabinet

Arrange the grounding of the drive module by leaving the contact surfaces of the fastening points unpainted (bare metal-to-metal contact). The module frame will be grounded to the PE busbar of the cabinet via the fastening surfaces, screws and the cabinet frame.

Alternatively, use a separate grounding conductor between the PE terminal of the drive module and the PE busbar of the cabinet.

Ground also the other components in the cabinet according to the principle above.

Selecting the busbar material and preparation of the joints

Note the following when you use busbars:

- Tin-plated copper is recommended but aluminum can also be used.
- The oxide layer from aluminum busbar joints must be removed and suitable anti-oxidant joint compound applied.

Tightening torques

Apply the following torques to grade 8.8 screws (with or without joint compound) that tighten electric contacts.

Screw size	Torque
M5	3.5 N·m (2.6 lbf·ft)
M6	9 N·m (6.6 lbf·ft)
M8	20 N·m (14.8 lbf·ft)
M10	40 N·m (29.5 lbf·ft)
M12	70 N·m (52 lbf·ft)
M16	180 N·m (133 lbf·ft)

Planning the fastening of the cabinet

Note the following when you plan the fastening of the cabinet:

- Fasten the cabinet to the floor from the front and to the floor or wall from the back.
- Always fasten the drive module from its fastening points to the cabinet. For details, see the module installation instructions.



WARNING! Do not fasten the cabinet by electric welding. ABB does not assume any liability for damages caused by electric welding as the welding circuit can damage electronic circuits in the cabinet. See section [Arc welding](#) on page 50.

Planning the cabinet placement on a cable channel

Note the following when you plan to place the cabinet on a cable channel:

- The cabinet structure must be sturdy enough. If the whole cabinet base is not supported from below, the cabinet weight will lie on the sections that the floor carries.
- Equip the cabinet with a sealed bottom plate and cable lead-throughs to ensure the degree of protection and to prevent the cooling air flow from the cable channel into the cabinet.

Note for option +B051: When the bottom grille and clear plastic shrouds around the motor cables are installed, the degree of protection of the drive module from bottom side is IP20.

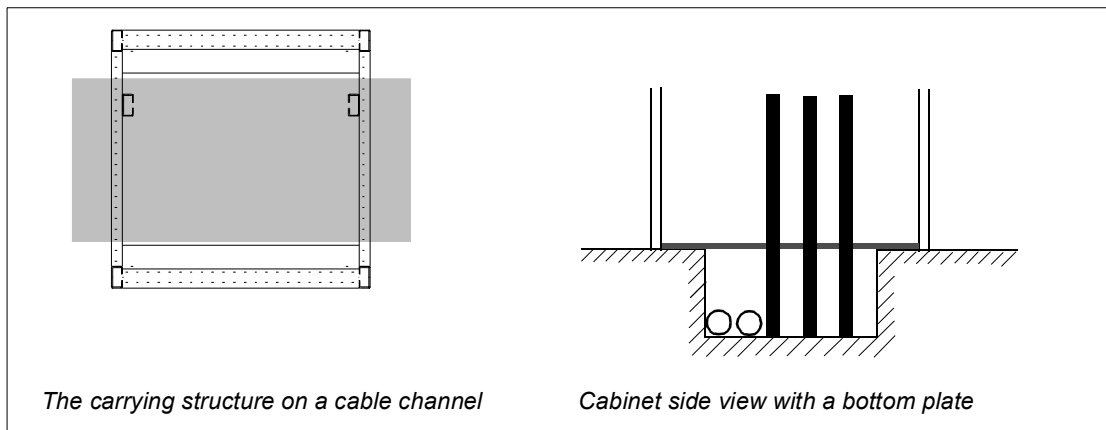

Planning the electromagnetic compatibility (EMC) of the cabinet

Note the following when you plan the electromagnetic compatibility of the cabinet:

- Generally, the fewer and smaller the holes in the cabinet, the better the interference attenuation. The maximum recommended diameter of a hole in galvanic metal contact in the covering cabinet structure is 100 mm (3.94 in). Pay special attention to the cooling air inlet and outlet gratings.
- The best galvanic connection between the steel panels is achieved by welding them together as no holes are necessary. If welding is not possible, we recommend to leave the seams between the panels **unpainted** and equipped with special conductive EMC strips to provide adequate galvanic connection. Usually, reliable strips are made of flexible silicon mass covered with a metal mesh. The non-tightened touch-contact of the metal surfaces is not sufficient, so a conductive gasket between the surfaces is required. The maximum recommended distance between assembly screws is 100 mm (3.94 in).
- Construct sufficient high-frequency grounding network in the cabinet to avoid voltage differences and forming of high-impedance radiator structures. A good high-frequency grounding is made with short flat copper braids for low inductance. One-point high-frequency grounding cannot be used due to the long distances inside the cabinet.
- 360° high frequency grounding of the cable shields at the cable lead-throughs improves the EMC shielding of the cabinet.

- We recommend 360° high frequency grounding of the motor cable shields at their entries. The grounding can be implemented by a knitted wire mesh screening as shown below.

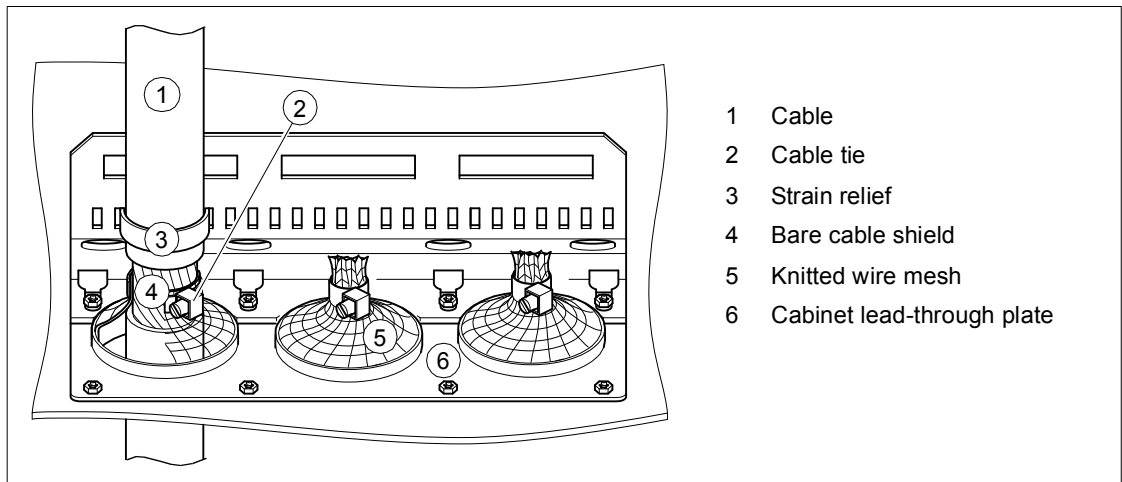

- We recommend 360° high frequency grounding of the control cable shields at their entries. The shields can be grounded by means of conductive shielding cushions pressed against the cable shield from both directions as shown below:

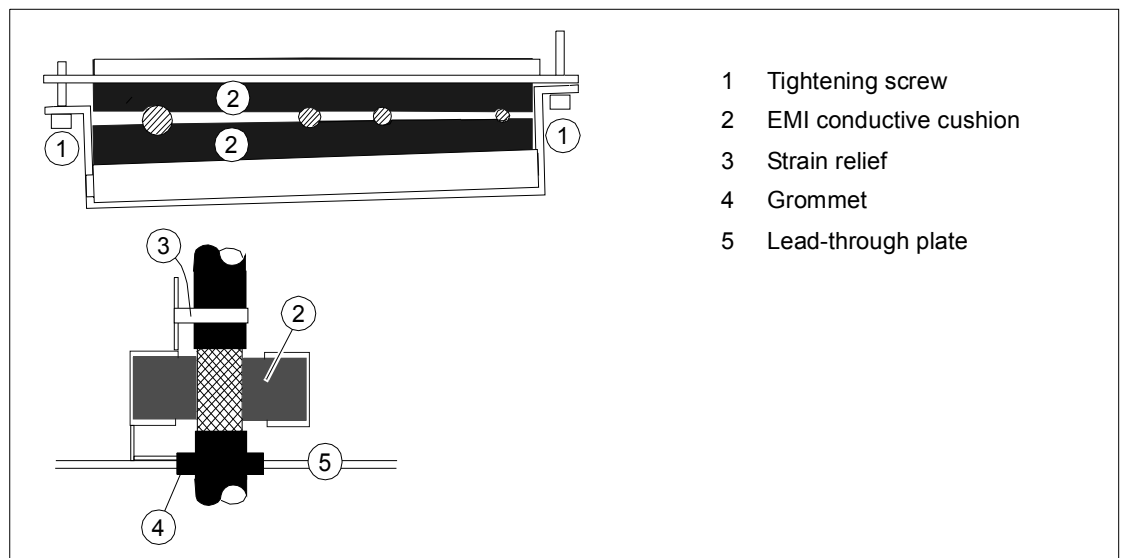

Planning the cooling

Note the following guidelines when you plan the cooling of the cabinet:

- Ventilate the installation site sufficiently so that the cooling air flow and ambient temperature requirements of the drive module are met, see pages 119 and 123. The internal cooling fan of the drive module rotates at a constant speed thus blowing constant air flow through the module. Whether the same amount of air must be replaced all the time in the facility depends on how much heat must be removed.
- Leave enough free space around the components to ensure sufficient cooling. Observe the minimum clearances given for each component. For the required free space around the drive module, see page 49.
- Also ventilate the heat dissipated by cables and other additional equipment.
- **Make sure that the air inlets and outlets are large enough to allow sufficient air flow in and out of the cabinet.** This is critical for proper cooling of the drive module.
- Equip the air inlets and outlets with gratings that
 - guide the air flow
 - protect against contact
 - prevent water splashes from entering the cabinet.
- The drawing below shows two typical cabinet cooling solutions. The air inlet is at the bottom of the cabinet, while the outlet is at the top, either on the upper part of the door or on the roof. We recommend that the air outlet is on the cabinet roof. Use an extra exhaust fan if the air outlet is on the cabinet door.

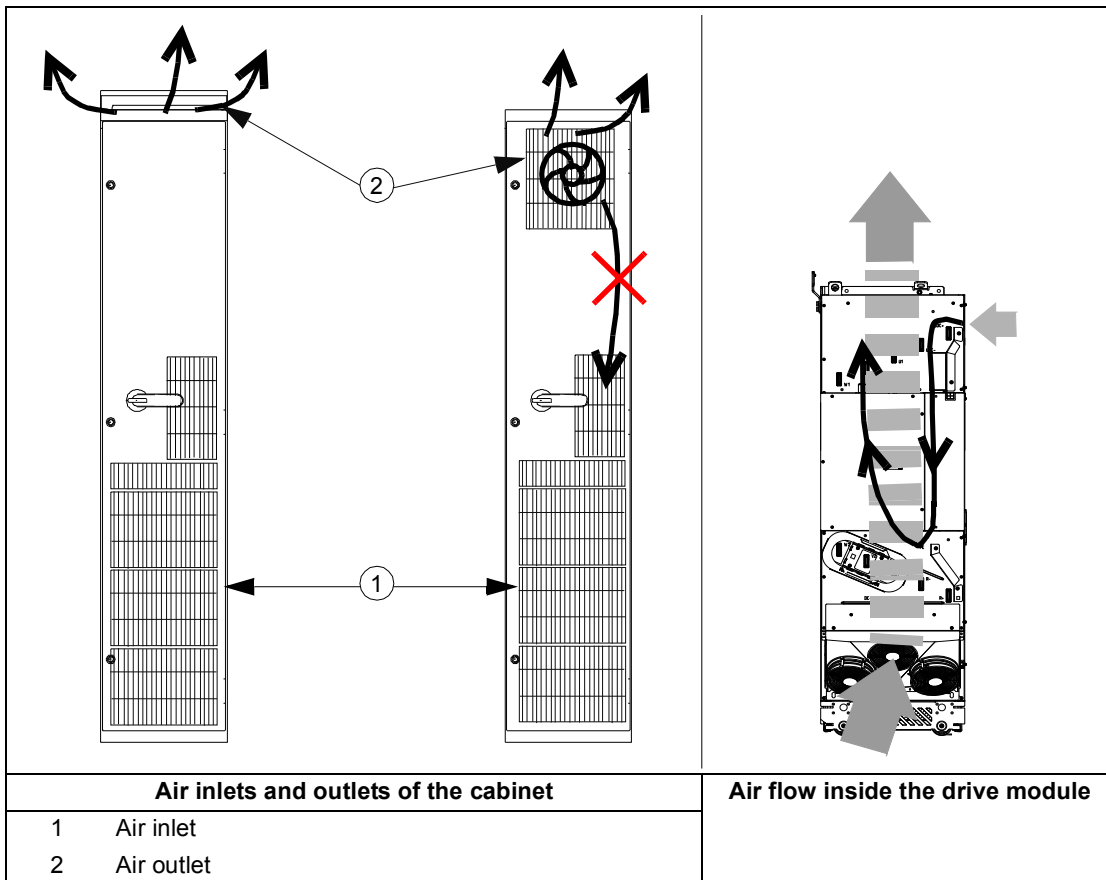

- The internal cooling fans of the drive modules and reactors/chokes are usually sufficient to keep the component temperatures low enough in IP22 cabinets.
- In IP54 cabinets, thick filter mats are used to prevent water splashes from entering the cabinet. This requires the installation of additional cooling equipment, such as a hot air exhaust fan.

Preventing the recirculation of hot air

Prevent hot air circulation outside the cabinet by leading the out coming hot air away from the area where the inlet air to the cabinet is taken. Possible solutions are listed below:

- gratings that guide air flow at the air inlet and outlet
- air inlet and outlet at different sides of the cabinet
- cool air inlet in the lower part of the front door, and an extra exhaust fan on the roof of the cabinet.

Prevent hot air circulation inside the cabinet with, for example, leak-proof air baffles. No gaskets are usually required.

Standard drive module configuration

This diagram shows air baffle positions inside an example cabinet. For the descriptions, see the next page.

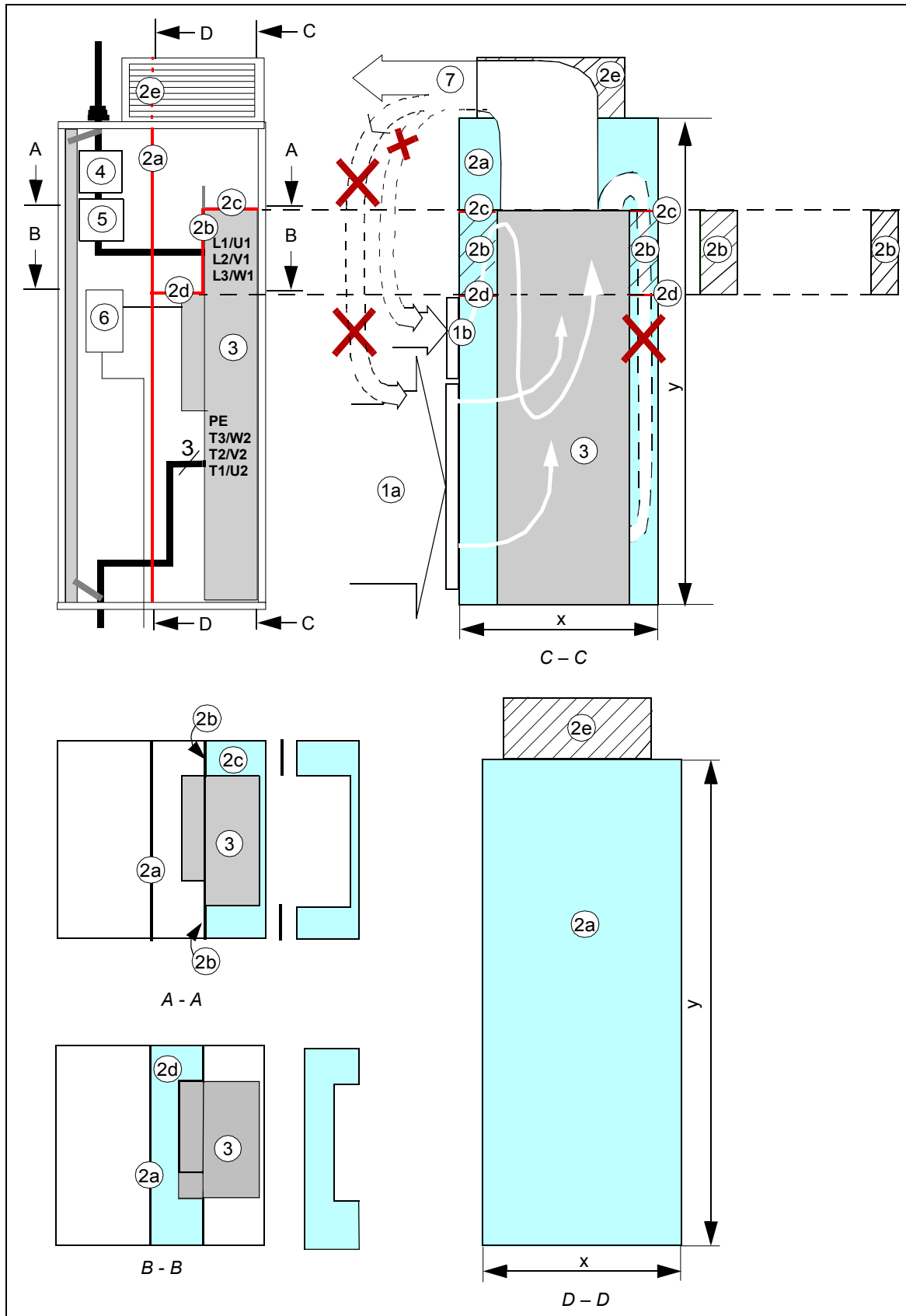

1a	Air flow to the drive module, max. 40 °C (104 °F)	2e	Optional air baffle that is needed when there is no fan on the lower part of the cabinet door (see 1b on page 38).
1b	Air inlet to the drive module circuit boards and DC output busbars	3	Drive module
2a	Vertical air baffle that separates the cool and hot areas in the cabinet	4	Disconnecter and fuses
2b	Vertical air baffle	5	Contactors
2c	Upper horizontal air baffle. For vertical location, see page 136.	6	Drive module control unit
2d	Lower horizontal air baffle	7	Air flow out

■ Drive module with option +B051

This diagram shows air baffle positions inside an example cabinet.

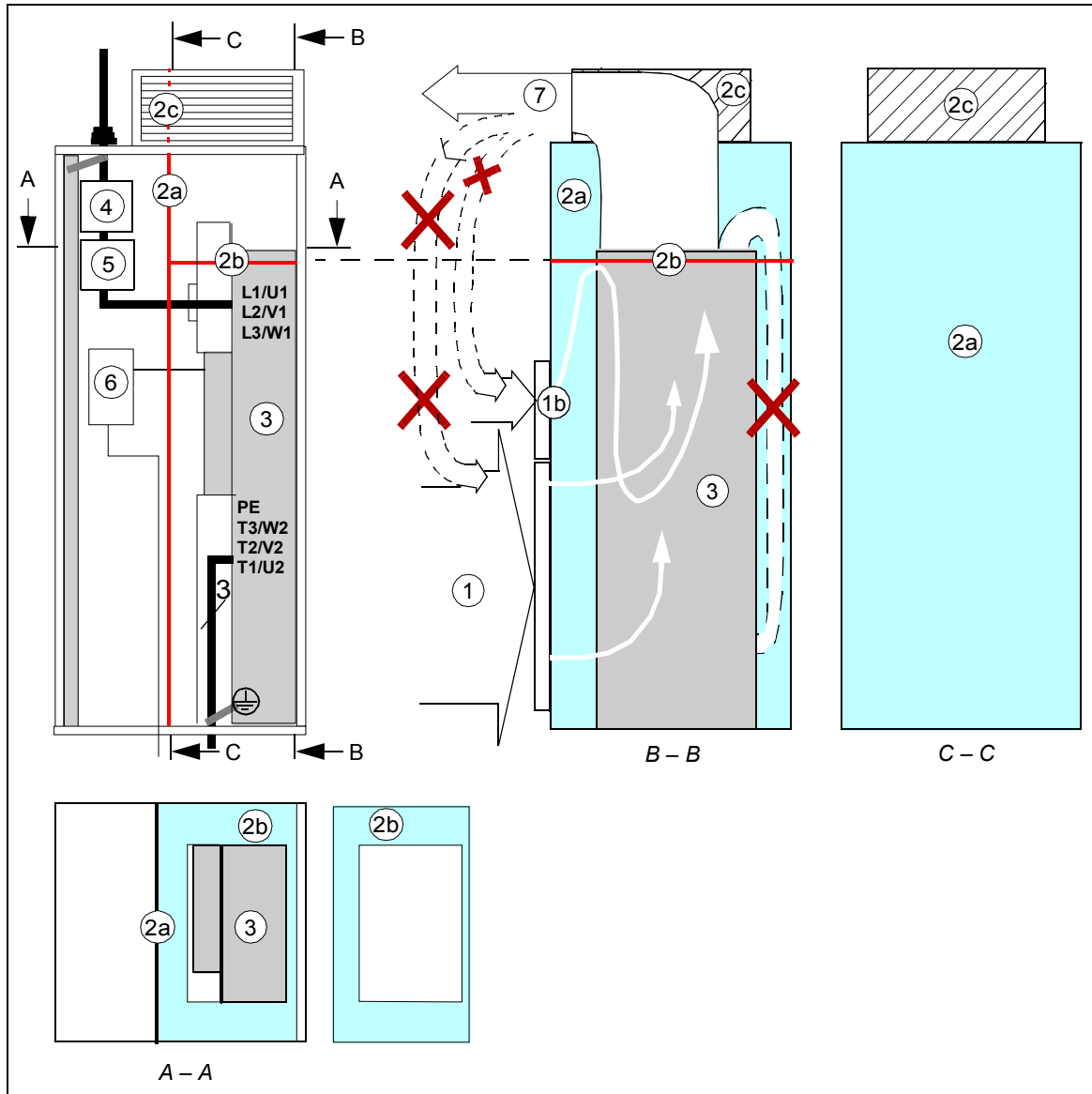

- | | |
|---|-----------------------------|
| 1a Air flow to the drive module, max. 40 °C (104 °F) | 3 Drive module |
| 1b Air inlet to the drive module circuit boards and DC output busbars | 4 Disconnecter and fuses |
| 2a Vertical air baffle that separates the cool and hot areas in the cabinet | 5 Contactor |
| 2b Horizontal air baffle, see page 136. | 6 Drive module control unit |
| 2c Optional air baffle that is needed when there is no fan on the lower part of the cabinet door (see 1b on page 38). | 7 Air flow out |

Required free space

Free space around the drive module is needed for ensuring that sufficient cooling air flows through the module and the module cools correctly.

■ Free space at the top of the drive module

The required free space at the top of the drive module is shown below.

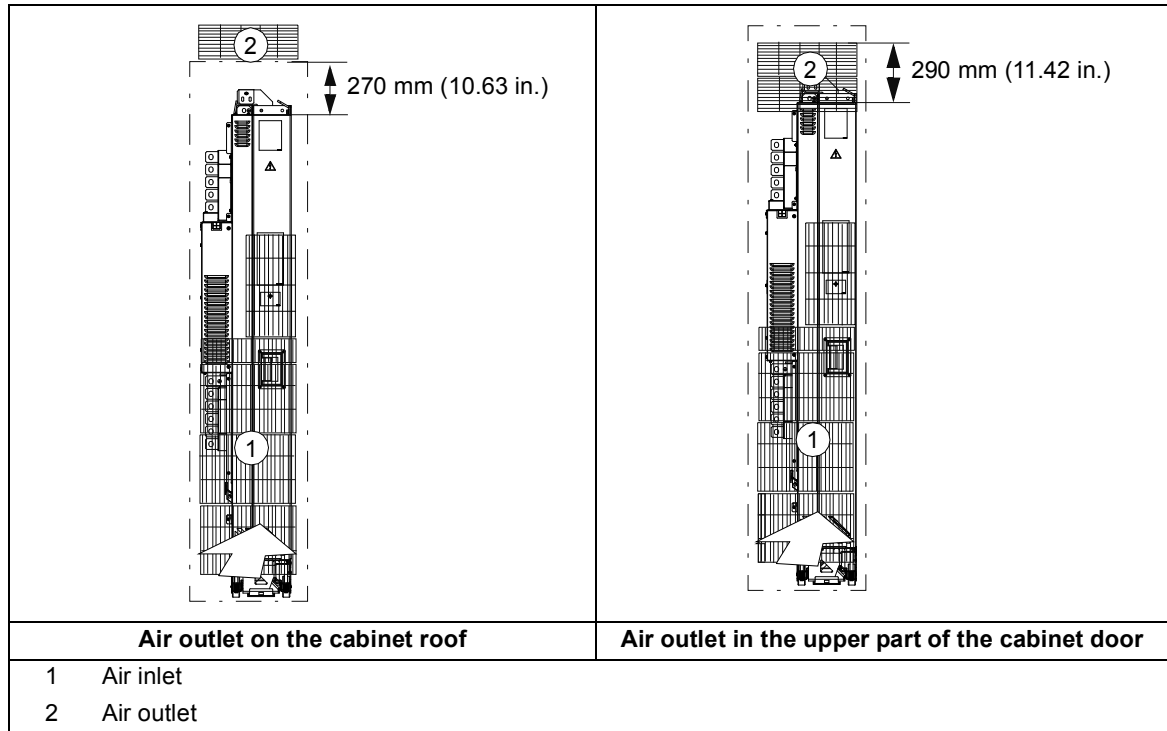

■ Free space around the drive module

20 mm (0.79 in.) free space around the drive module is required from the cabinet back panel and front door. No free space for cooling is required on the left- and right-hand sides of the module.

The module can be installed in a cabinet with the following dimensions:

- width 500 mm (19.68 in.)
- depth 600 mm (23.62 in.)
- height 2000 mm (78.74 in.).

Other installation positions

Contact your local ABB representative for more information.

■ Drive module on its back

If you install the drive module on its back, make sure that the hot cooling air that flows upwards from the module does not cause danger.

Planning the placement of the control panel

Note the following alternatives when you plan the placement of the control panel:

- As standard, the control panel is integrated on the control unit inside the drive module.
- The control panel can be mounted onto the cabinet door using a control panel mounting platform (option +J410). For instructions, see *DPMP-02/03 control panel mounting platform kit installation guide* (3AUA0000136205 [English]).

Planning the use of cubicle heaters

Use a cubicle heater if there is a risk of condensation in the cabinet. Although the primary function of the heater is to keep the air dry, it may also be required for heating at low temperatures.

Arc welding

Fastening the cabinet by arc welding is not allowed due to risk of electrical component failure. However, if the arc welding is the only mounting option, remove the module from the cabinet before welding.



5

Guidelines for planning the electrical installation

Contents of this chapter

This chapter contains the instructions that you must obey when you select the motor, cables, protections, cable routing and way of operation for the drive system.

Limitation of liability

The installation must always be designed and made according to applicable local laws and regulations. ABB does not assume any liability whatsoever for any installation which breaches the local laws and/or other regulations. Furthermore, if the recommendations given by ABB are not obeyed, the drive can experience problems that the warranty does not cover.

Selecting the supply disconnecting device

Install a hand-operated input disconnecting device between the AC power source and the drive. The disconnecting device must be of a type that can be locked to the open position for installation and maintenance work.

■ European Union

To meet the European Union Directives, according to standard EN 60204-1, *Safety of Machinery*, the disconnecting device must be one of the following types:

- switch-disconnector of utilization category AC-23B (EN 60947-3)
- disconnector that has an auxiliary contact that in all cases causes switching devices to break the load circuit before the opening of the main contacts of the disconnector (EN 60947-3)
- circuit breaker suitable for isolation in accordance with EN 60947-2.

■ Other regions

The disconnecting device must conform to the applicable safety regulations.

Selecting the main contactor

If a main contactor is used, its utilization category (number of operations under load) must be AC-1 according to IEC 60947-4, *Low-voltage switchgear and controlgear*. Select the contactor according to the nominal voltage and current of the drive.

Examining the compatibility of the motor and drive

Use an AC induction motor, synchronous reluctance motor or synchronous permanent magnet motor with the drive. Several induction motors can be connected at a time.

Select the motor size and drive type from the rating tables in chapter [Technical data](#) on basis of the AC line voltage and motor load.

Make sure that the motor withstands the maximum peak voltage in the motor terminals, see the [Requirements table](#) on page 53. For basics of protecting the motor insulation and bearings in drive systems, refer to section [Protecting the motor insulation and bearings](#) below.

Note:

- Consult the motor manufacturer before you use a motor which nominal voltage differs from the AC line voltage connected to the drive input.
- The voltage peaks at the motor terminals are relative to the supply voltage of the drive, not the drive output voltage.

■ Protecting the motor insulation and bearings

The drive uses modern IGBT inverter technology. Regardless of frequency, the drive output has pulses of approximately the drive DC bus voltage with a very short rise time. Up to twice bus voltage can be at the motor terminals, depending on the attenuation and reflection properties of the motor cable and the terminals. The increased voltage can cause additional stress on the motor and motor cable insulation.

Modern variable speed drives with their fast rising voltage pulses and high switching frequencies can generate current pulses that flow through the motor bearings. This can gradually erode the bearing races and rolling elements.

Optional du/dt filters protect motor insulation system and reduce bearing currents. Optional common mode filters mainly reduce bearing currents. Insulated N-end (non-drive end) bearings protect the motor bearings.

■ Requirements table

The following table shows how to select the motor insulation system and when optional ABB du/dt filters, insulated N-end (non-drive end) motor bearings and ABB common mode filters are required. Failure of the motor to fulfil the following requirements or improper installation may shorten motor life or damage the motor bearings and voids the warranty.

Motor type	Nominal AC supply voltage	Requirement for		
		Motor insulation system	ABB du/dt and common mode filters, insulated N-end motor bearings	
			$100 \text{ kW} \leq P_N < 350 \text{ kW}$ or $\text{IEC } 315 \leq \text{frame size} < \text{IEC } 400$	$P_N \geq 350 \text{ kW}$ or $\text{frame size} \geq \text{IEC } 400$
			$134 \text{ hp} \leq P_N < 469 \text{ hp}$ or $\text{NEMA } 500 \leq \text{frame size} \leq \text{NEMA } 580$	$P_N \geq 469 \text{ hp}$ or $\text{frame size} > \text{NEMA } 580$
ABB motors				
Random-wound M2_ and M4_	$U_N \leq 500 \text{ V}$	Standard	+ N	+ N + CMF
Form-wound HX_ and AM_	$380 \text{ V} < U_N \leq 690 \text{ V}$	Standard	+ N + CMF	$P_N < 500 \text{ kW}$: +N + CMF
				$P_N \geq 500 \text{ kW}$ +N + du/dt + CMF
Old* form-wound HX_ and modular	$380 \text{ V} < U_N \leq 690 \text{ V}$	Check with the motor manufacturer.	+ N + du/dt with voltages over 500 V + CMF	
Random-wound HX_ and AM_**	$0 \text{ V} < U_N \leq 500 \text{ V}$	Enamelled wire with fiber glass taping	+ N + CMF	
HDP	Consult the motor manufacturer.			

* manufactured before 1.1.1998

** For motors manufactured before 1.1.1998, check for additional instructions with the motor manufacturer.

Non-ABB motors				
Random-wound and form-wound	$U_N \leq 420 \text{ V}$	Standard: $\dot{U}_{LL} = 1300 \text{ V}$	+ N or CMF	+ N + CMF
	$420 \text{ V} < U_N \leq 500 \text{ V}$	Standard: $\dot{U}_{LL} = 1300 \text{ V}$	+ du/dt + (N or CMF)	+ N + du/dt + CMF
		or Reinforced: $\dot{U}_{LL} = 1600 \text{ V}$, 0.2 microsecond rise time	+ N or CMF	+ N + CMF

The abbreviations used in the table are defined below.

Abbreviation	Definition
U_N	Nominal AC line voltage
\hat{U}_{LL}	Peak line-to-line voltage at motor terminals which the motor insulation must withstand
P_N	Motor nominal power
du/dt	du/dt filter at the output of the drive
CMF	Common mode filter (option +E208)
N	N-end bearing (Insulated motor non-drive end bearing)

Additional requirements for ABB motors of types other than M2_, M3_, M4_, HX_ and AM_

Use the selection criteria given for non-ABB motors.

Additional requirements for ABB high-output and IP23 motors

The rated output power of high output motors is higher than what is stated for the particular frame size in EN 50347:2001. This table shows the requirements for ABB random-wound motor series (for example, M3AA, M3AP and M3BP).

Nominal AC supply voltage	Motor insulation system	Requirement for	
		ABB du/dt and common mode filters, insulated N-end motor bearings	
		$100 \text{ kW} \leq P_N < 200 \text{ kW}$	$P_N \geq 200 \text{ kW}$
		$140 \text{ hp} \leq P_N < 268 \text{ hp}$	$P_N \geq 268 \text{ hp}$
$U_N \leq 500 \text{ V}$	Standard	+ N	+ N + CMF

Additional requirements for non-ABB high-output and IP23 motors

The rated output power of high output motors is higher than what is stated for the particular frame size in EN 50347:2001. The table below shows the requirements for random-wound and form-wound non-ABB motors with nominal power smaller than 350 kW. For bigger motors, consult the motor manufacturer.

Nominal AC supply voltage	Motor insulation system	Requirement for	
		ABB du/dt filter, insulated N-end bearing and ABB common mode filter	
		$100 \text{ kW} \leq P_N < 350 \text{ kW}$ or IEC 315 \leq frame size $<$ IEC 400	
		$134 \text{ hp} \leq P_N < 469 \text{ hp}$ or NEMA 500 \leq frame size \leq NEMA 580	
$U_N \leq 420 \text{ V}$	Standard: $\hat{U}_{LL} = 1300 \text{ V}$	+ N + CMF	
$420 \text{ V} < U_N \leq 500 \text{ V}$	Standard: $\hat{U}_{LL} = 1300 \text{ V}$	+ N + du/dt + CMF	
	or Reinforced: $\hat{U}_{LL} = 1600 \text{ V}$, 0.2 microsecond rise time	+ N + CMF	

Additional data for calculating the rise time and the peak line-to-line voltage

The diagrams below show the relative peak line-to-line voltage and rate of change of voltage as a function of the motor cable length with and without a du/dt filter in use.

To calculate the actual peak voltage for a certain cable length read the relative \hat{U}_{LL}/U_N value from the appropriate diagram and multiply it by the nominal supply voltage (U_N).

To calculate the actual voltage rise time for a certain cable length read the relative values \hat{U}_{LL}/U_N and $(du/dt)/U_N$ from the appropriate diagram. Multiply the values by the nominal supply voltage (U_N) and substitute into equation $t = 0.8 \cdot \hat{U}_{LL}/(du/dt)$.

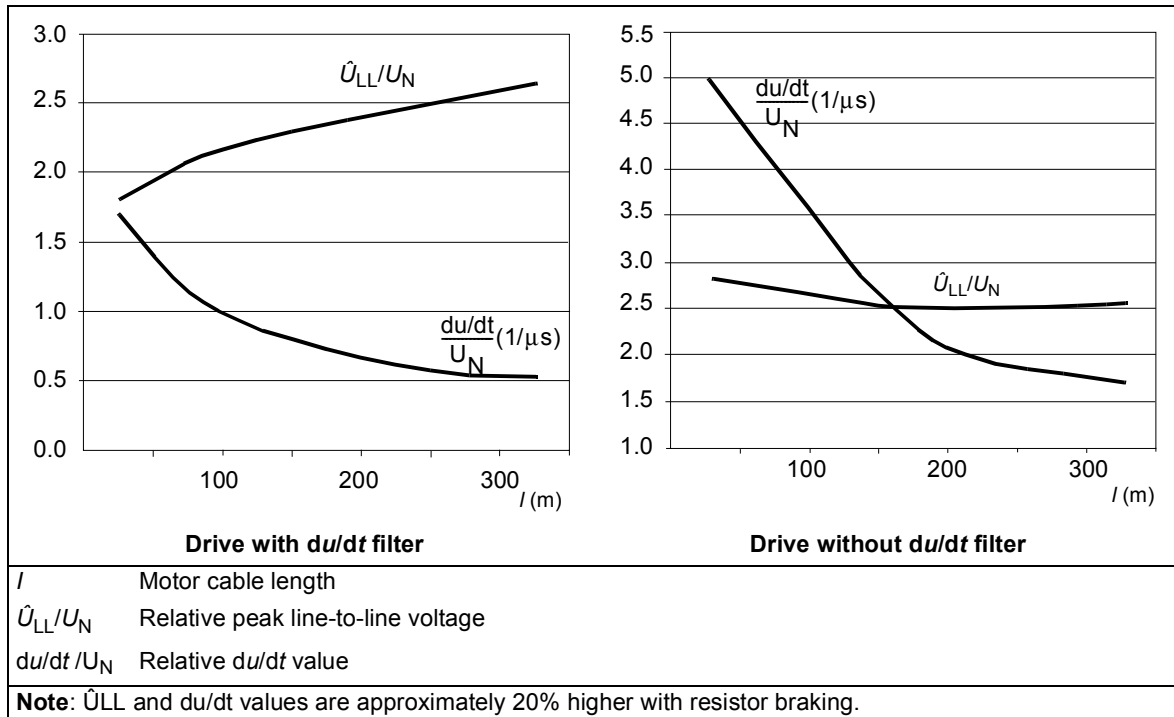

Additional note for common mode filters

Common mode filters are available as plus code option +E208.

Selecting the power cables

■ General rules

Select the input power and motor cables according to local regulations:

- Select a cable capable of carrying the drive nominal current. See section [Ratings](#) (page [115](#)) for the rated currents.
- Select a cable rated for at least 70 °C (158 °F) maximum permissible temperature of conductor in continuous use. For US, see [Selecting the control cables](#), page [59](#).
- The inductance and impedance of the PE conductor/cable (grounding wire) must be rated according to permissible touch voltage appearing under fault conditions (so that the fault point voltage will not rise excessively when a ground fault occurs).
- 600 V AC cable is accepted for up to 500 V AC.

Use symmetrical shielded motor cables (see page [58](#)). Ground motor cable shields 360° at both ends. Keep the motor cable and its PE pigtail (twisted shield) as short as possible to reduce high-frequency electromagnetic emissions.

Note: When continuous metal conduit is employed, shielded cable is not required. The conduit must have bonding at both ends.

A four-conductor system is allowed for input cabling, but shielded symmetrical cable is recommended.

Compared to a four-conductor system, the use of symmetrical shielded cable reduces electromagnetic emission of the whole drive system as well as the stress on motor insulation, bearing currents and wear.

■ Sufficient conductivity of the protective conductor

The protective conductor must always have an adequate conductivity.

Unless local wiring regulations state otherwise, the cross-sectional area of the protective conductor must meet the conditions that require automatic disconnection of the supply required in 411.3.2. of IEC 60364-4-41:2005 and be capable of withstanding the prospective fault current during the disconnection time of the protective device.

The cross-sectional area of the protective conductor can either be selected from the table below or calculated according to 543.1 of IEC 60364-5-54.

This table shows the minimum cross-sectional area related to the phase conductor size according to IEC 61800-5-1 when the phase conductor and the protective conductor are made of the same metal. If this is not so, the cross-sectional area of the protective earthing conductor shall be determined in a manner which produces a conductance equivalent to that which results from the application of this table.

Cross-sectional area of the phase conductors S (mm ²)	Minimum cross-sectional area of the corresponding protective conductor S_p (mm ²)
$S \leq 16$	S
$16 < S \leq 35$	16
$35 < S$	$S/2$

■ Typical power cable sizes

The table below gives copper and aluminium cable types with concentric copper shield for the drives with nominal current. See also [Terminal and lead-through data for the power cables](#) on page 119.

Drive type ACS580- 04-	IEC ¹⁾	
	Cu cable type	Al cable type
	mm ²	mm ²
$U_N = 380 \dots 415 \text{ V}$ (380, 400, 415 V)		
505A-4	3 × (3×95)	3 × (3×150)
585A-4	3 × (3×120)	3 × (3×185)
650A-4	3 × (3×150)	3 × (3×240)
725A-4	3 × (3×185)	4 × (3×185)
820A-4	3 × (3×240)	4 × (3×240)
880A-4	3 × (3×240)	4 × (3×240)
$U_N = 440 \dots 480 \text{ V}$ (440, 460, 480 V)		
505A-4	3 × (3×95)	3 × (3×150)
585A-4	3 × (3×95)	3 × (3×150)
650A-4	3 × (3×120)	3 × (3×185)
725A-4	3 × (3×150)	3 × (3×240)
820A-4	3 × (3×185)	4 × (3×185)
880A-4	3 × (3×240)	4 × (3×240)

3AXD00000588487

- 1) The cable sizing is based on max. 9 cables laid on a cable ladder side by side, three ladder type trays one on top of the other, ambient temperature 30 °C (86 °F) PVC insulation, surface temperature 70 °C (158 °F) (EN 60204-1 and IEC 60364-5-52). For other conditions, dimension the cables according to local safety regulations, appropriate input voltage and the load current of the drive.

Alternative power cable types

The recommended and not allowed power cable types to be used with the drive are presented below.

Recommended power cable types

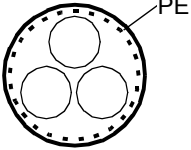
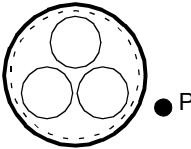
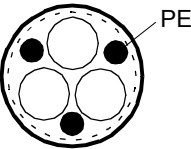
	<p>Symmetrical shielded cable with three phase conductors and a concentric PE conductor as shield. The shield must meet the requirements of IEC 61800-5-1, see section Motor cable shield on page 58. Check with local / state / country electrical codes for allowance.</p>
	<p>Symmetrical shielded cable with three phase conductors and a concentric PE conductor as shield. A separate PE conductor is required if the shield does not meet the requirements of IEC 61800-5-1, see section Motor cable shield on page 58.</p>
	<p>Symmetrical shielded cable with three phase conductors and symmetrically constructed PE conductor, and a shield. The PE conductor must meet the requirements of IEC 61800-5-1, see section Motor cable shield on page 58.</p>

Power cable types for restricted use

	<p>A four-conductor system (three phase conductors and a protective conductor on a cable tray) is not allowed for motor cabling (allowed for input cabling).</p>
---	---

Not allowed power cable types

	<p>Symmetrical shielded cable with individual shields for each phase conductor is not allowed on any cable size for input and motor cabling.</p>
---	--

Motor cable shield

If the motor cable shield is used as the sole protective earth conductor of the motor, make sure that the conductivity of the shield is sufficient. See subsection [General rules](#) on page 55, or IEC 61800-5-1. To effectively suppress radiated and conducted radio-frequency emissions, the cable shield conductivity must be at least 1/10 of the phase conductor conductivity. The requirements are easily met with a copper or aluminum shield. The minimum requirement of the motor cable shield of the drive is shown below. It consists of a concentric layer of copper wires with an open helix of copper tape or copper wire. The better and tighter the shield, the lower the emission level and bearing currents.

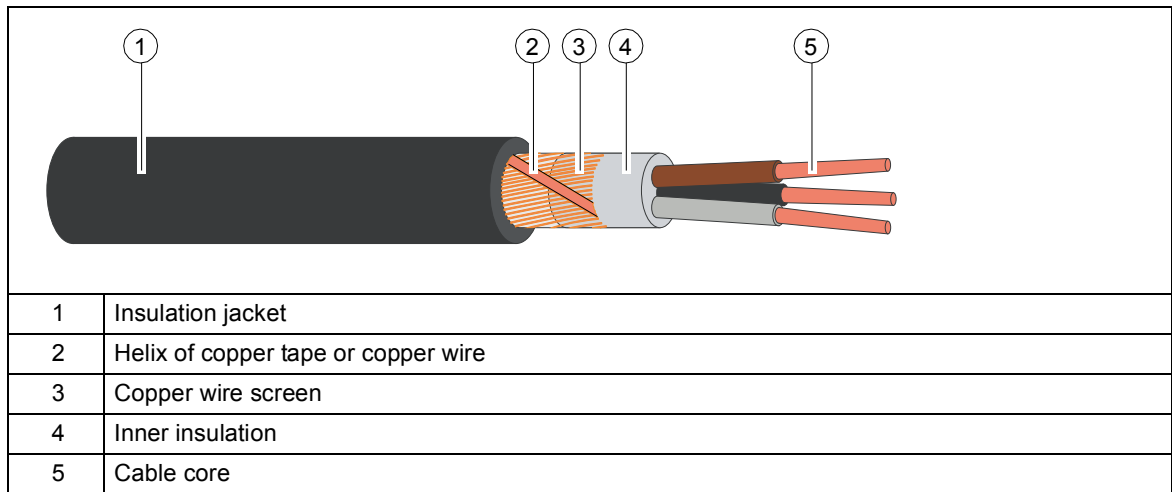

Selecting the control cables

■ Shielding

All control cables must be shielded.

Use a double-shielded twisted pair cable for analog signals. We recommend this type of cable for the pulse encoder signals also. Employ one individually shielded pair for each signal. Do not use common return for different analog signals.

A double-shielded cable (figure a below) is the best alternative for low-voltage digital signals but single-shielded (b) twisted pair cable is also acceptable.

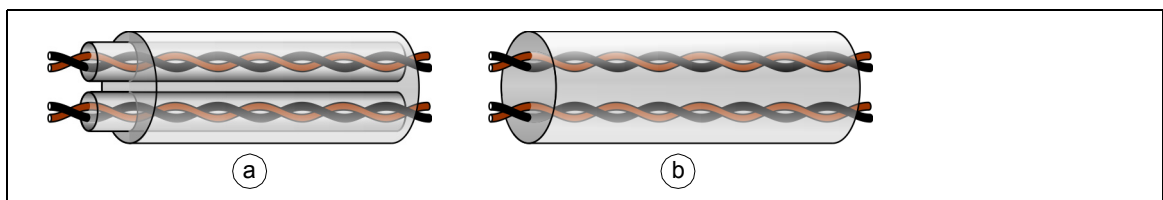

■ Signals in separate cables

Run analog and digital signals in separate, shielded cables. Never mix 24 V DC and 115/230 V AC signals in the same cable.

■ Signals allowed to be run in the same cable

Relay-controlled signals, providing their voltage does not exceed 48 V, can be run in the same cables as digital input signals. The relay-controlled signals should be run as twisted pairs.

■ Relay cable type

The cable type with braided metallic screen (for example ÖLFLEX by LAPPKABEL, Germany) has been tested and approved by ABB.

■ Control panel cable length and type

In remote use, the cable connecting the control panel to the drive must not exceed three meters (10 ft). Cable type: shielded CAT 5e or better Ethernet patch cable with RJ-45 ends.

■ Routing the cables

Route the motor cable away from other cable routes. Motor cables of several drives can be run in parallel when installed next to each other. The motor cable, input power cable and control cables should be installed on separate trays. Avoid long parallel runs of motor cables with other cables in order to decrease electromagnetic interference caused by the rapid changes in the drive output voltage.

Where control cables must cross power cables, make sure they are arranged at an angle as near to 90 degrees as possible. Do not install extra cables through the drive.

The cable trays must have good electrical bonding to each other and to the grounding electrodes. Aluminum tray systems can be used to improve local equalizing of potential

A diagram of the cable routing is shown below.

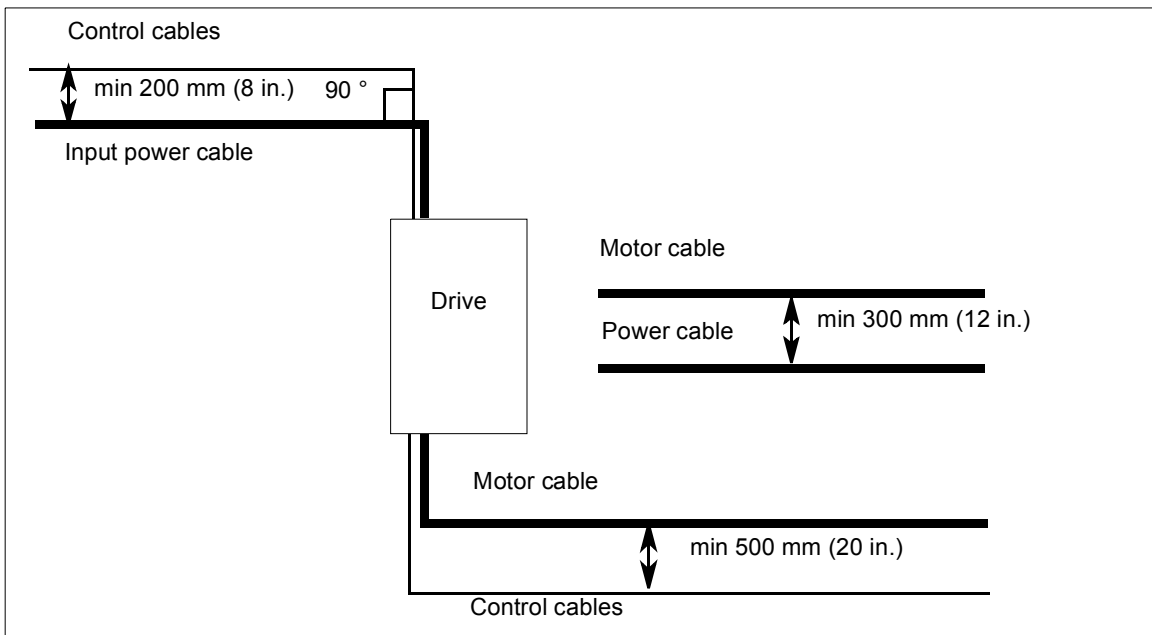

■ Separate control cable ducts

Lead 24 V and 230 V (120 V) control cables in separate ducts unless the 24 V cable is insulated for 230 V (120 V) or insulated with an insulation sleeving for 230 V (120 V).

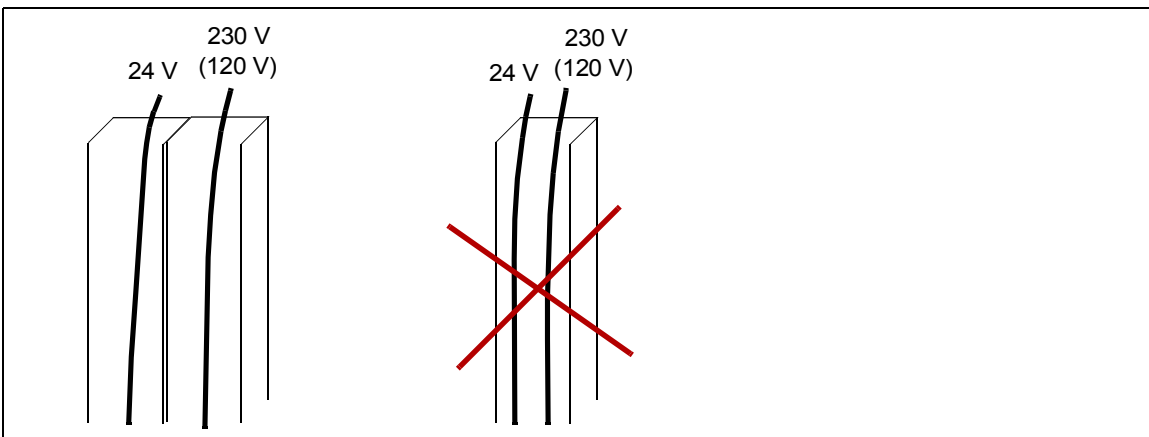

■ Continuous motor cable shield or enclosure for equipment in the motor cable

To minimize the emission level when safety switches, contactors, connection boxes or similar equipment are installed on the motor cable between the drive and the motor:

- European Union: Install the equipment in a metal enclosure with 360 degree grounding for the shields of both the incoming and outgoing cable, or connect the shields of the cables otherwise together.
- US: Install the equipment in a metal enclosure in a way that the conduit or motor cable shielding runs consistently without breaks from the drive to the motor.

Implementing thermal overload and short-circuit protection

■ Protecting the drive and input power cable in short-circuits

Protect the drive with fuses (a) and the input cable with fuses (b) as shown below:

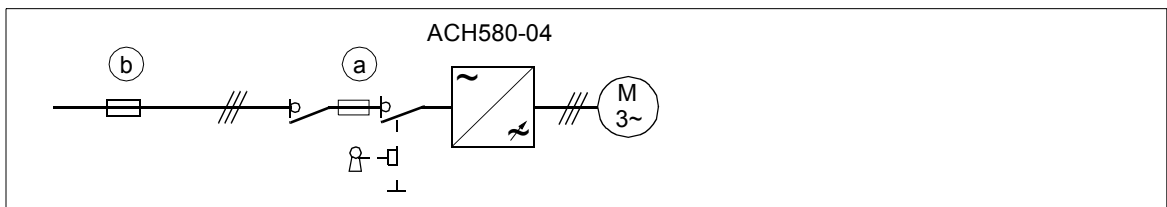

Size the fuses or the circuit breaker at the distribution board according to local regulations for the input cable protection. Select the fuses for the drive according to the instructions given in chapter *Technical data*. The fuses for the drive protection will restrict drive damage and prevent damage to adjoining equipment in case of a short-circuit inside the drive.

Note 1: If the fuses for the drive protection are placed at the distribution board and the input cable is dimensioned according to the nominal input current of the drive given in the rating table on page 115, the fuses will protect also the input cable in short-circuit situations, restrict drive damage and prevent damage to adjoining equipment in case of a short-circuit inside the drive. No separate fuses for the input cable protection are needed.

Note 2: Circuit breakers must not be used without fuses. For more information, contact ABB.

■ Protecting the motor and motor cable in short-circuits

The drive protects the motor cable and motor in a short-circuit situation when the motor cable is dimensioned according to the nominal current of the drive. No additional protection devices are needed.

■ Protecting the drive and the input power and motor cables against thermal overload

The drive protects itself and the input and motor cables against thermal overload when the cables are dimensioned according to the nominal current of the drive. No additional thermal protection devices are needed.



WARNING! If the drive is connected to multiple motors, use a separate circuit breaker or fuses for protecting each motor cable and motor against overload. The drive overload protection is tuned for the total motor load. It may not trip due to an overload in one motor circuit only.

■ Protecting the motor against thermal overload

According to regulations, the motor must be protected against thermal overload and the current must be switched off when overload is detected. The drive includes a motor thermal protection function that protects the motor and switches off the current when necessary. Depending on a drive parameter value, the function either monitors a calculated temperature value (based on a motor thermal model) or an actual temperature indication given by motor temperature sensors. The user can tune the thermal model further by feeding in additional motor and load data.

The most common temperature sensors are:

- motor sizes IEC 180...225: thermal switch, eg, Klixon
- motor sizes IEC 200...250 and larger: PTC or Pt100.

See the firmware manual for more information on the motor thermal protection, and the connection and use of the temperature sensors.

Protecting the drive against ground faults

The drive is equipped with an internal ground fault protective function to protect the drive against ground faults in the motor and motor cable in TN (grounded) networks. This is not a personal safety or a fire protection feature. The ground fault protective function can be disabled with a parameter, refer to the firmware manual.

Measures for protection in case of direct or indirect contact, such as separation from the environment by double or reinforced insulation or isolation from the supply system by a transformer, can be applied.

■ Residual current device compatibility

The drive is suitable to be used with residual current devices of Type B.

Note: The EMC filter of the drive includes capacitors connected between the main circuit and the frame. These capacitors and long motor cables increase the ground leakage current and can cause fault current circuit breakers to function.

Implementing the Emergency stop function

For safety reasons, install the emergency stop devices at each operator control station and at other operating stations where emergency stop may be needed. You can implement the emergency stop function using the Safe torque off function of the drive module (see chapter [Safe torque off function](#) on page 139). Design the emergency stop according to relevant standards.

Note: Pressing the stop key  on the control panel of the drive does not generate an emergency stop of the motor or separate the drive from dangerous potential.

Implementing the Safe torque off function

See chapter [Safe torque off function](#) on page 139.

Implementing the Power loss ride-through function

Implement the power-loss ride-through function as follows:

- Check that the power-loss ride-through function of the drive is enabled with parameter **30.31 Undervoltage control**.
- Set parameter **21.01 Vector start mode** to **Automatic** (in vector mode) or parameter **21.19 Scalar start mode** to **Automatic** (in scalar mode) to make flying start (starting into a rotating motor) possible. If the installation is equipped with a main contactor, prevent its tripping at the input power break. For example, use a time delay relay (hold) in the contactor control circuit.



WARNING! Make sure that the flying restart of the motor will not cause any danger. If you are in doubt, do not implement the Power-loss ride-through function.

Using power factor compensation capacitors with the drive

Power factor compensation is not needed with AC drives. However, if a drive is to be connected in a system with compensation capacitors installed, contact ABB for instructions.

Implementing a safety switch between the drive and the motor

We recommended that you install a safety switch between the permanent magnet motor and the drive output. The switch is needed to isolate the motor during any maintenance work on the drive.

Using a contactor between the drive and the motor

Implementing the control of the output contactor depends on how you select the drive to operate. See also section [Implementing a bypass connection](#) on page 64.

When you have selected to use

- vector control mode and motor ramp stop,

open the contactor as follows:

1. Give a stop command to the drive.
2. Wait until the drive decelerates the motor to zero speed.
3. Open the contactor.

When you have selected to use

- vector control mode and motor coast stop; or scalar control mode,

open the contactor as follows:

1. Give a stop command to the drive.
2. Open the contactor.



WARNING! When the vector control mode is in use, never open the output contactor while the drive controls the motor. The vector control operate extremely fast, much faster than it takes for the contactor to open its contacts. When the contactor starts opening while the drive controls the motor, the vector control will try to maintain the load current by immediately increasing the drive output voltage to the maximum. This will damage, or even burn the contactor completely.

Implementing a bypass connection

If bypassing is required, employ mechanically or electrically interlocked contactors between the motor and the drive and between the motor and the power line. Make sure with interlocking that the contactors cannot be closed simultaneously. The installation must be clearly marked as defined in IEC/EN 61800-5-1, subclause 6.5.3, for example, "THIS MACHINE STARTS AUTOMATICALLY".



WARNING! Never connect the drive output to the electrical power network. The connection may damage the drive.

■ Example bypass connection

An example bypass connection is shown below.

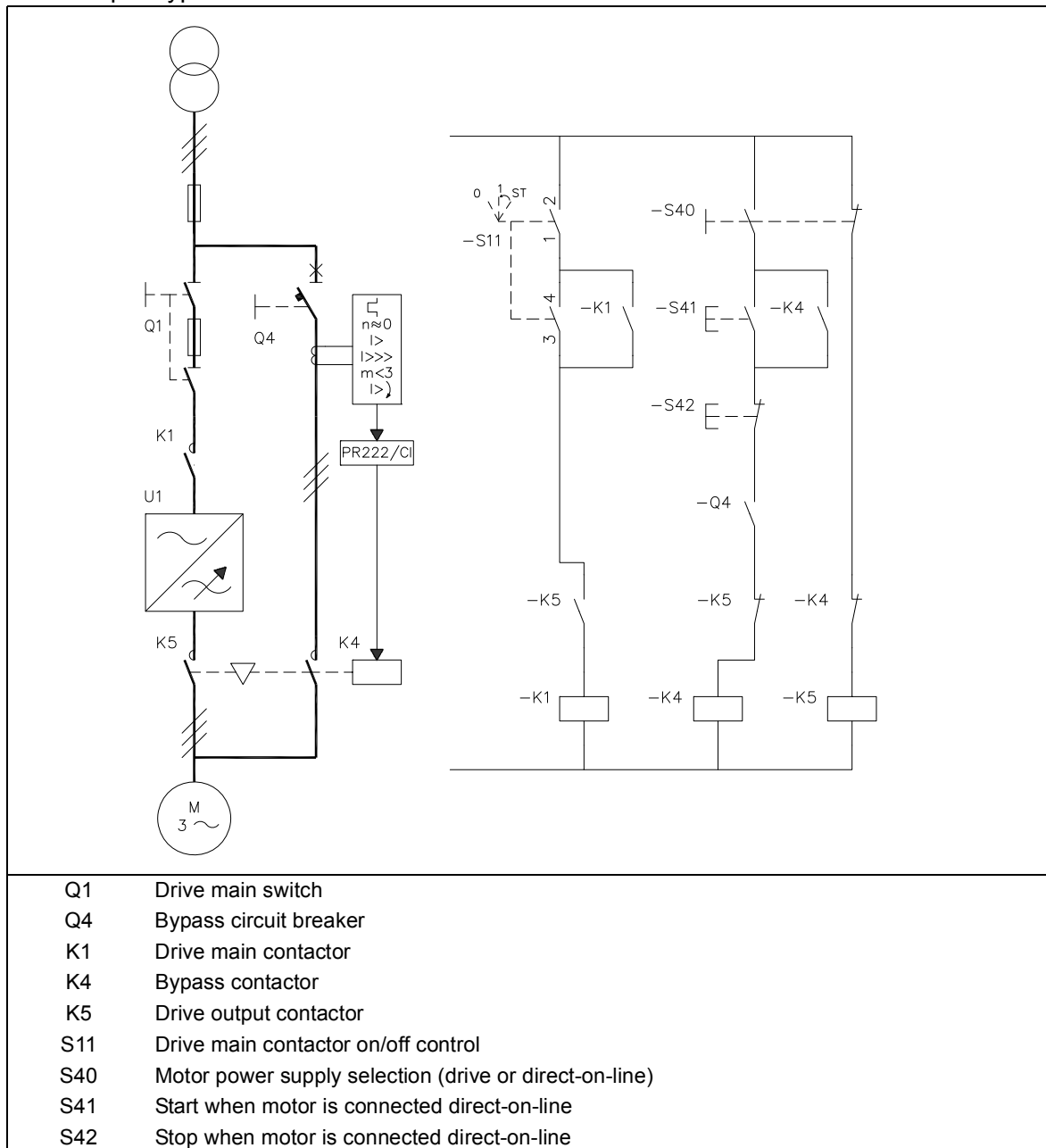

Switching the motor power supply from drive to direct-on-line

1. Stop the drive and the motor with the drive control panel (drive in the local control mode) or the external stop signal (drive in the remote control mode).
2. Open the main contactor of the drive with S11.
3. Switch the motor power supply from the drive to direct-on-line with S40.
4. Wait for 10 seconds to allow the motor magnetization to die away.
5. Start the motor with S41.

Switching the motor power supply from direct-on-line to drive

1. Stop the motor with S42.
2. Switch the motor power supply from direct-on-line to the drive with S40.
3. Close the main contactor of the drive with switch S11 (-> turn to position ST for two seconds and leave to position 1).
4. Start the drive and the motor with the drive control panel (drive in the local control mode) or the external start signal (drive in the remote control mode).

Protecting the contacts of relay outputs

Inductive loads (relays, contactors, motors) cause voltage transients when switched off.

The relay contacts on the drive control unit are protected with varistors (250 V) against overvoltage peaks. In spite of this, it is highly recommended that inductive loads are equipped with noise attenuating circuits (varistors, RC filters [AC] or diodes [DC]) in order to minimize the EMC emission at switch-off. If not suppressed, the disturbances may connect capacitively or inductively to other conductors in the control cable and form a risk of malfunction in other parts of the system.

Install the protective component as close to the inductive load as possible. Do not install protective components at the relay outputs.

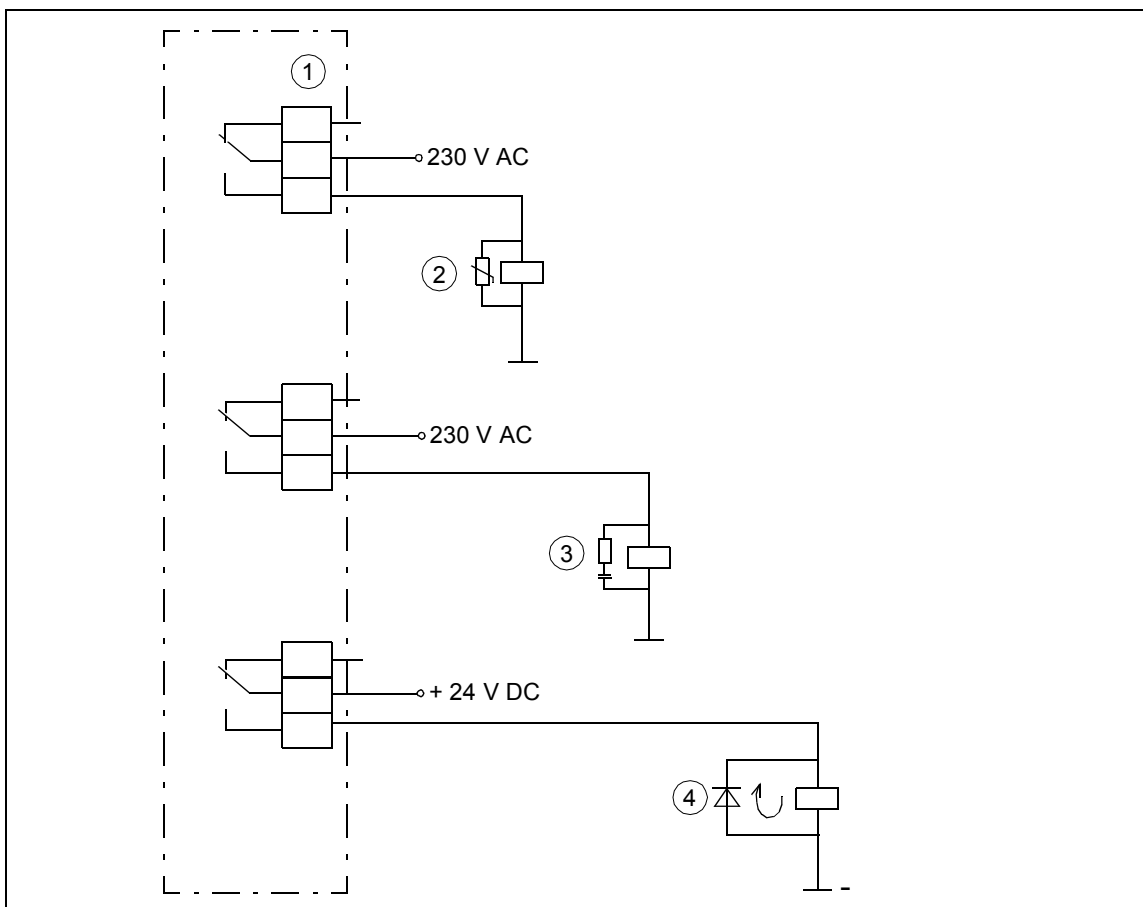

1) Relay outputs; 2) Varistor; 3) RC filter; 4) diode

Connecting a motor temperature sensor to the drive I/O



WARNING! IEC 60664 requires double or reinforced insulation between live parts and the surface of accessible parts of electrical equipment which are either non-conductive or conductive but not connected to the protective earth.

To fulfil this requirement, you can connect a thermistor (and other similar components) to the inputs of the drive:

- If there is double or reinforced insulation between the thermistor and live parts of the motor or
- if circuits connected to all digital and analog inputs of the drive are protected against contact and insulated with basic insulation (the same voltage level as the drive main circuit) from other low voltage circuits.

Another way is to use an optional thermistor protection module or an external thermistor relay. The insulation of the relay must be rated for the same voltage level as the main circuit of the drive. For connection to the relay, see the firmware manual. For connection to the thermistor protection module, see its manual.

See also sections

- [AI1 and AI2 as Pt100, Pt1000, Ni1000, KTY83 and KTY84 sensor inputs \(X1\)](#) on page 88
- [CMOD-02 multifunction extension module \(external 24 V AC/DC and isolated PTC interface\)](#) on page 166
- [CPTC-02 ATEX-certified thermistor protection module, \(external 24 V AC/DC and isolated PTC interface\)](#) on page 172.

Example circuit diagram

See page [137](#).

6

Installation instructions

Contents of this chapter

This chapter contains the general installation instructions for the drive module. The chapter refers to the installation example chapters which contain instructions that depend on the selected drive configuration.



Safety



WARNING! If you are not a qualified electrician do not do the installation work described in this chapter. Obey the instructions in chapter [Safety instructions](#). If you ignore them, injury or death, or damage to the equipment can occur.

Checking the installation site

The material below the drive must be non-flammable and strong enough to carry the weight of the drive.

See section [Ambient conditions](#) on page [123](#) for the allowed ambient conditions and section [Losses, cooling data and noise](#) on page [119](#) for the required cooling air.

Moving and unpacking the unit



WARNING! Obey the safety instructions in chapter [Safety instructions](#). If you ignore them, injury or death, or damage to the equipment can occur.

Move the transport package by pallet truck to the installation site.

Unpack the package as follows (see the package drawing on page [71](#)):

- Cut the bands (A).
- Unpack the additional boxes (B).
- Remove the outer sheathing by lifting it (C).
- Remove the sheathing by lifting it (D).
- Remove the pedestal guide plate (not included with options +0H354 and +0P919) as shown below.

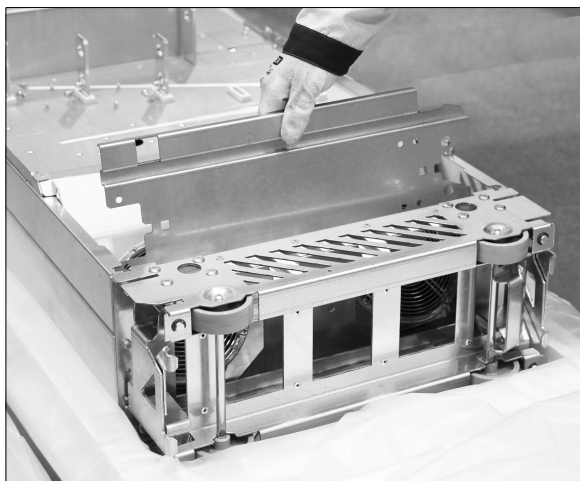

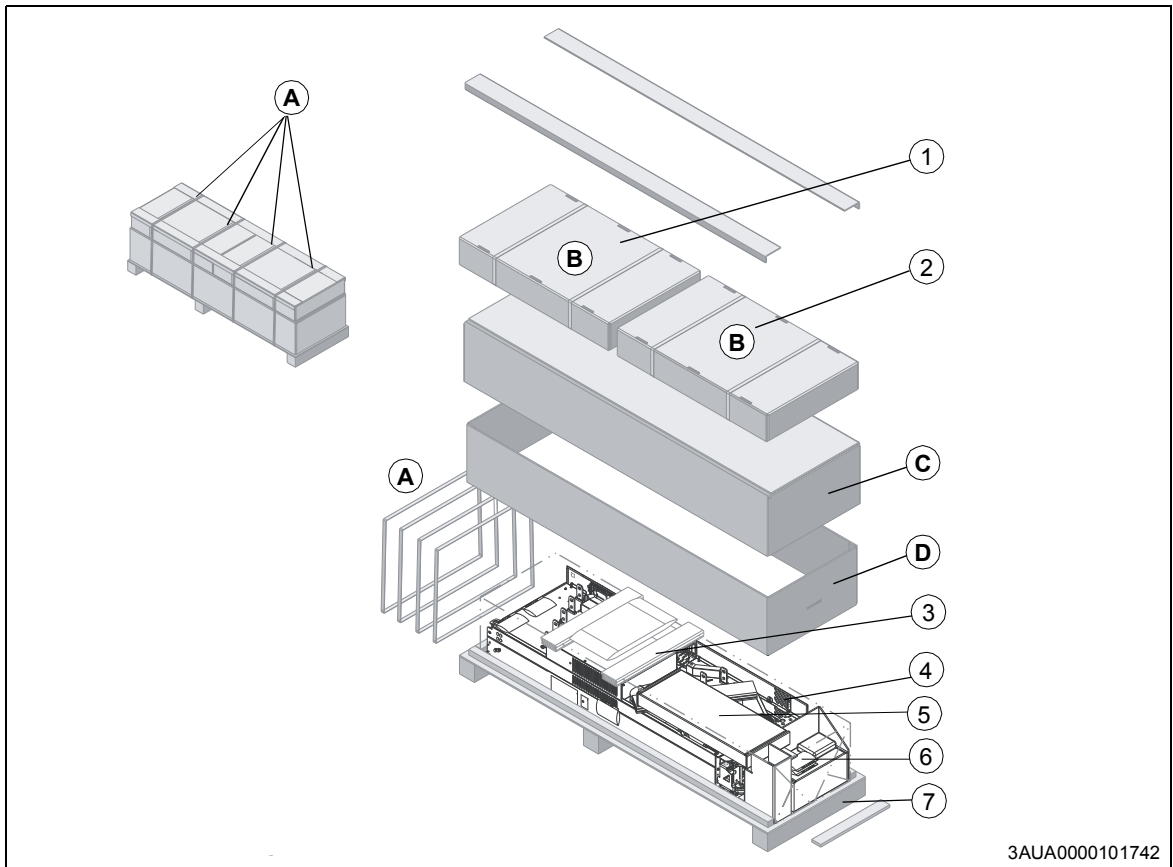

3AUA0000101742

Transport package contents

1	<u>With option +B051:</u> Clear plastic shrouds. See below for the box contents.
2	<u>With standard drive module configuration:</u> Output cable connection terminals. See below for the box contents.
3	Plywood support
4	Drive module with factory installed options and multilingual residual voltage warning sticker, top guide plate, pedestal guide plate, telescopic ramp package, fastening screws in a plastic bag, control unit options, delivery documents, printed multilingual installation and start-up quick guide. Other printed manuals if ordered.
5	Ramp box. <u>With option +H370:</u> also input cable connection terminals box.
6	Accessories box
7	Pallet



3AXD5000009484

Box B1 contents (option +B051)	
1	Paper fill
2	Clear plastic shroud for output cabling
3	Cardboard box cover
4	Cardboard box bottom
5	Support
6	Bands
7	Back clear plastic shroud (lower)
8	Back clear plastic shroud (upper)
9	Front clear plastic shroud
10	Clear plastic shroud for input cabling
11	Top clear plastic shroud
12	Clear plastic shroud for input cable lead-through from side
13	Screws in a plastic bag
14	Metallic shroud
15	Bottom grille and mounting bracket



33AXD5000009515

Box B2 contains this box with standard drive module configuration	
1	Paper fill
2	Output cable connection terminal T3/W2
3	Output cable connection terminal T2/V2
4	Output cable connection terminal T1/U2
5	Grounding terminal
6	Cardboard box
7	Screws and insulators a plastic bag

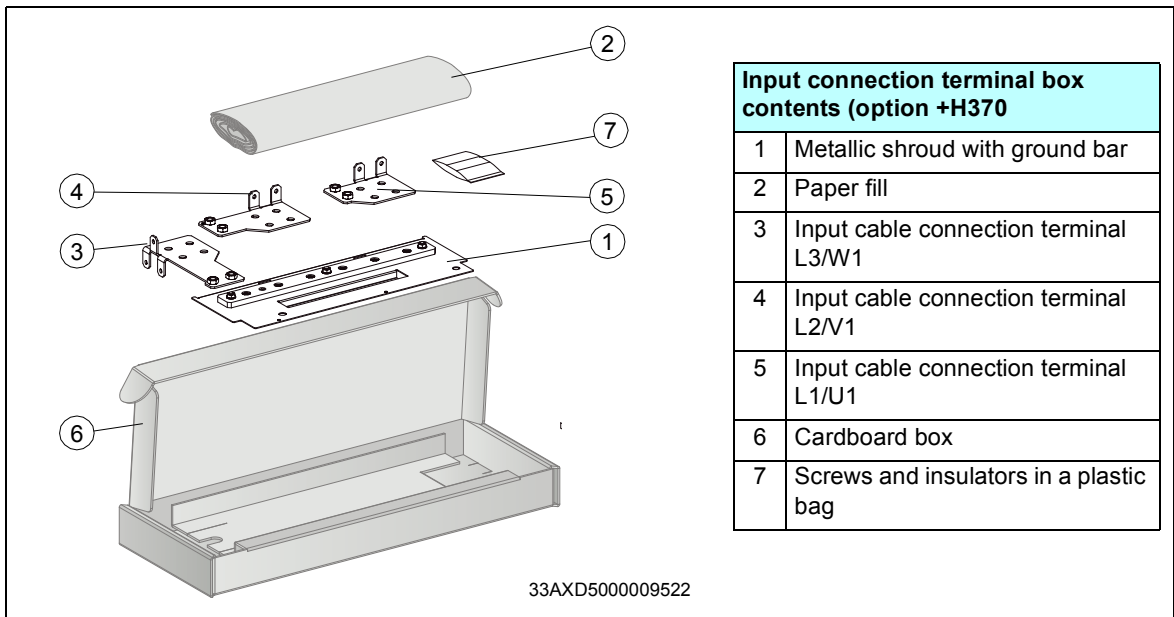

Input connection terminal box contents (option +H370)

1	Metallic shroud with ground bar
2	Paper fill
3	Input cable connection terminal L3/W1
4	Input cable connection terminal L2/V1
5	Input cable connection terminal L1/U1
6	Cardboard box
7	Screws and insulators in a plastic bag

33AXD5000009522

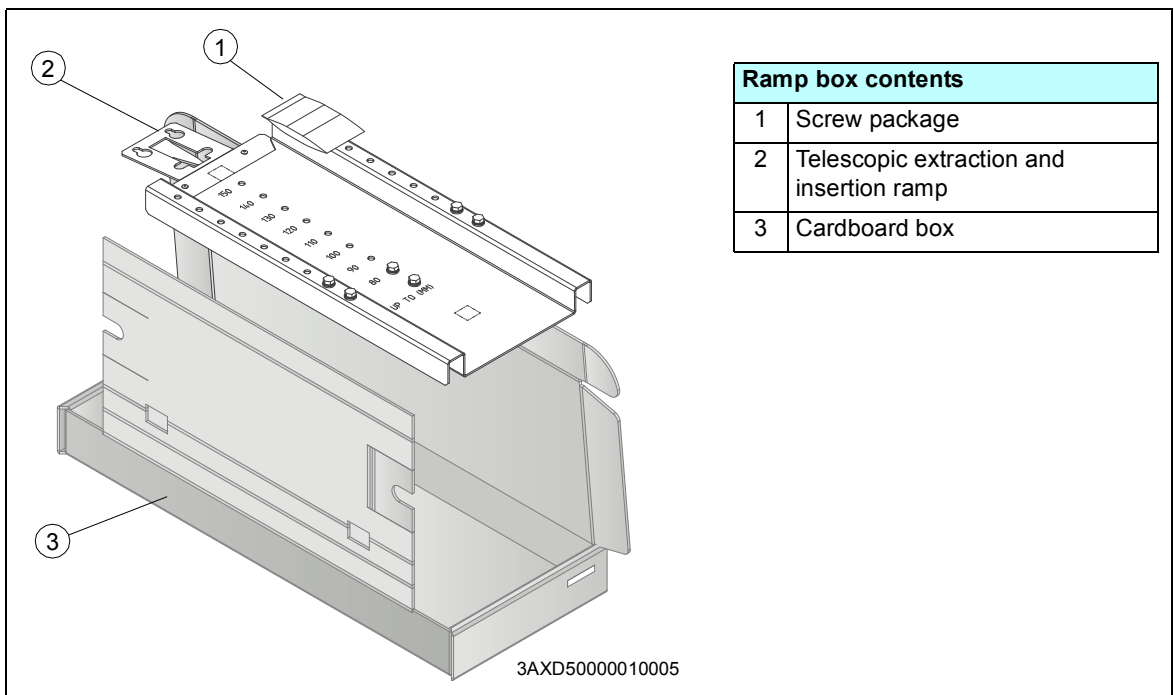

Ramp box contents

1	Screw package
2	Telescopic extraction and insertion ramp
3	Cardboard box

3AXD50000010005



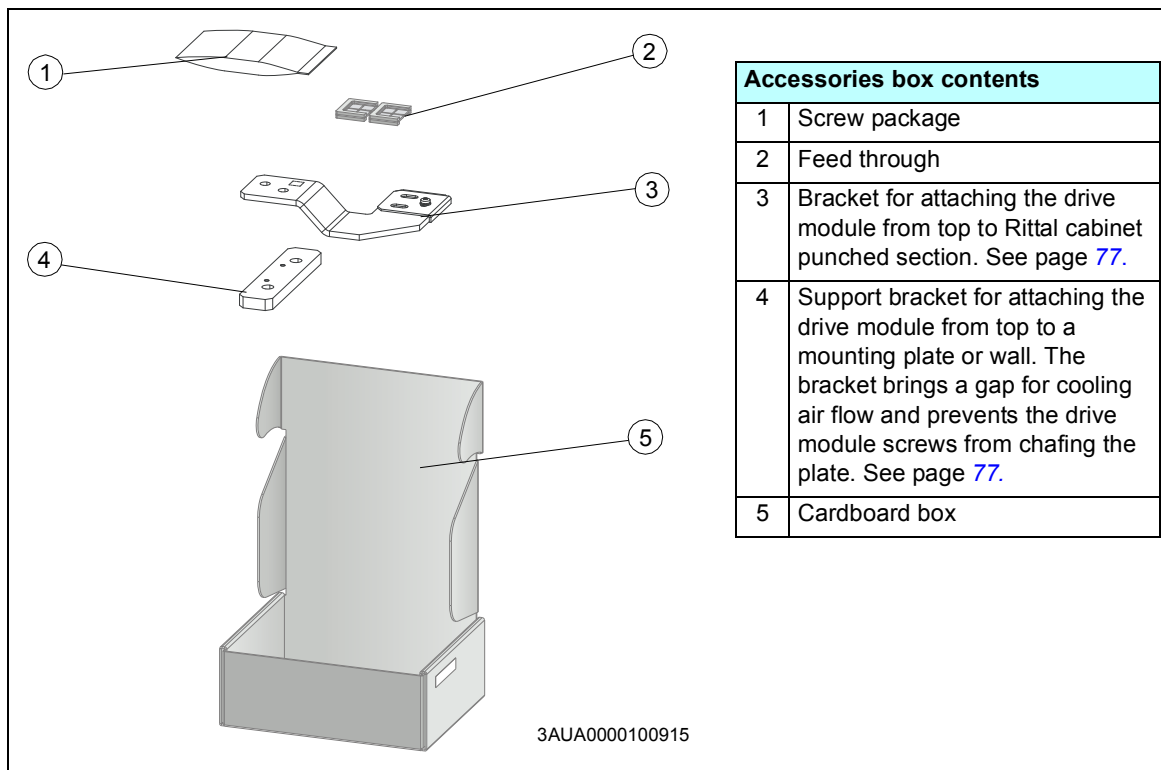

Checking the delivery

Check that all items listed in section [Moving and unpacking the unit](#) are present.

Check that there are no signs of damage. Before attempting installation and operation, check the information on the type designation label of the drive to verify that the unit is of the correct type.

Installing the motor cable at the motor end

Ground the motor cable shield 360 degrees at the lead-through of the motor terminal box.

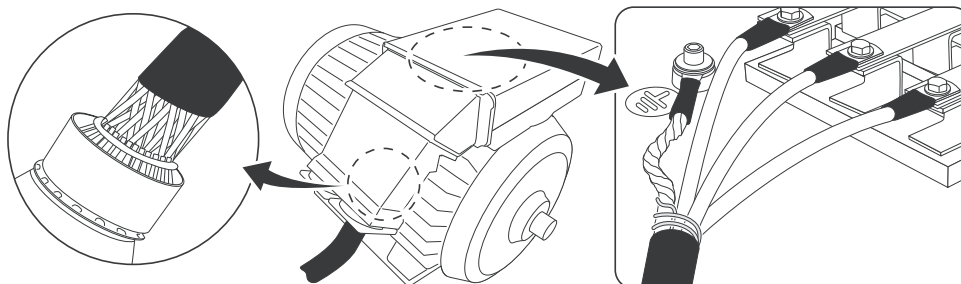

Checking the insulation of the assembly

■ Drive

Do not make any voltage tolerance or insulation resistance tests on any part of the drive as testing can damage the drive. Every drive has been tested for insulation between the main circuit and the chassis at the factory. Also, there are voltage-limiting circuits inside the drive which cut down the testing voltage automatically.

■ Input cable

Check the insulation of the input cable according to local regulations before connecting it to the drive.

■ Motor and motor cable

Check the insulation of the motor and motor cable as follows:

1. Check that the motor cable is disconnected from the drive output terminals T1/U2, T2/V2 and T3/W2.
2. Measure the insulation resistance between each phase conductor and the Protective Earth conductor using a measuring voltage of 1000 V DC. The insulation resistance of an ABB motor must exceed 100 Mohm (reference value at 25 °C or 77 °F). For the insulation resistance of other motors, consult the manufacturer's instructions. **Note:** Moisture inside the motor casing will reduce the insulation resistance. If you suspect moisture, dry the motor and repeat the measurement.

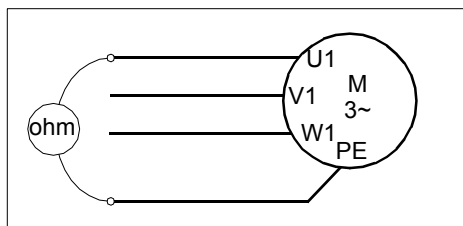

Installation alternatives

For an installation example of how to install the standard drive module into a Rittal cabinet, see chapter [Installation example of drive module with IP20 shrouds \(option +B051\)](#). You can install the drive module into a cabinet using different procedures depending on the drive configuration. Obey the general power and control cable installation instructions that we give in this chapter and see the installation example of your drive configuration in the following chapters.

■ Standard drive module configuration and option +B051

For an installation example on how to install the drive module into a Rittal TS 8 cabinet, see chapter [Installation example of drive module with IP20 shrouds \(option +B051\)](#) on page 91. See also *ACS580-04 drive modules (200 to 560 kW, 300 to 700 hp) quick installation guide* (3AXD50000015469 [English]).

■ Optional input power cable connection terminals and ground busbar assembly (+H370)

Connect the input power cable connection terminals as shown in chapter [Step-by-step drawings for an installation example of drive module with options +B051 and +E208 in Rittal TS 8 600 mm wide cabinet](#) on page 175.



Install the metallic shroud with ground bar as shown below.

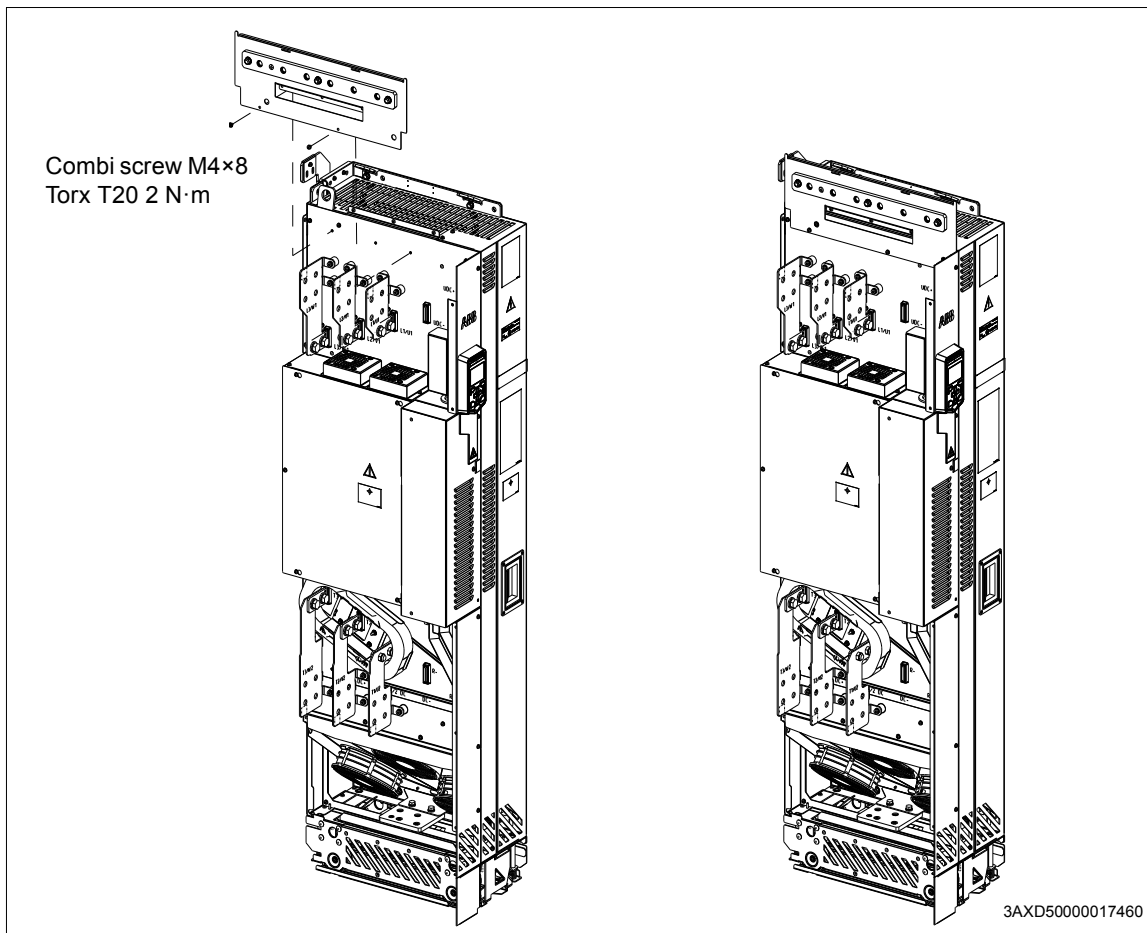

■ **Drive module without output cable connection terminals (option +0H371)**

The power cables can be connected directly to the drive module input and output terminals with cable lugs or by busbars.

■ **Drive module without pedestal (option +0H354)**

The drive module without pedestal can be mounted on a wall or a cabinet with four screws through the fastening holes at the top and bottom of the module.

Make sure that the cabinet mounting plate and frame are strong enough to carry the weight of the drive module. See section [Dimensions, weights and free space requirements](#) on page 119.

■ Attaching the drive module to a mounting plate or wall

Use the support bracket if you attach the drive module directly to a mounting plate or wall. The support bracket prevents the drive module screws from chafing against the plate.

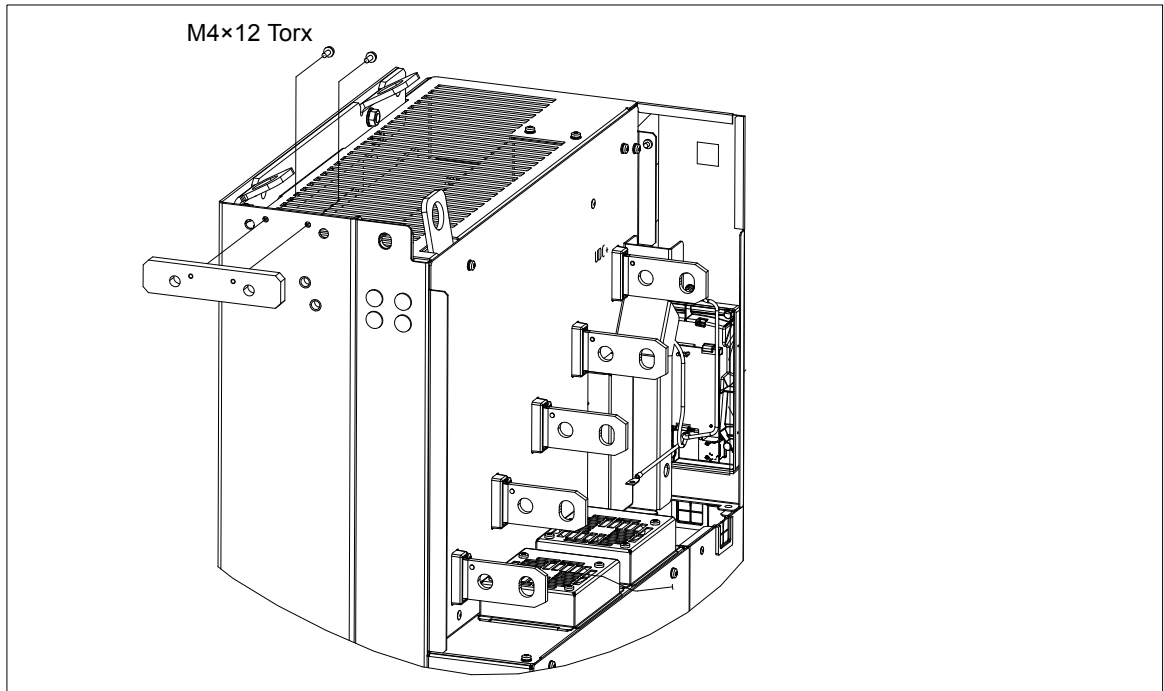

■ Alternatives for grounding the drive module

You can ground the drive module from its top back to the cabinet frame with these alternatives:

1. from the grounding hole
2. to a Rittal punched section: with the fastening bracket.

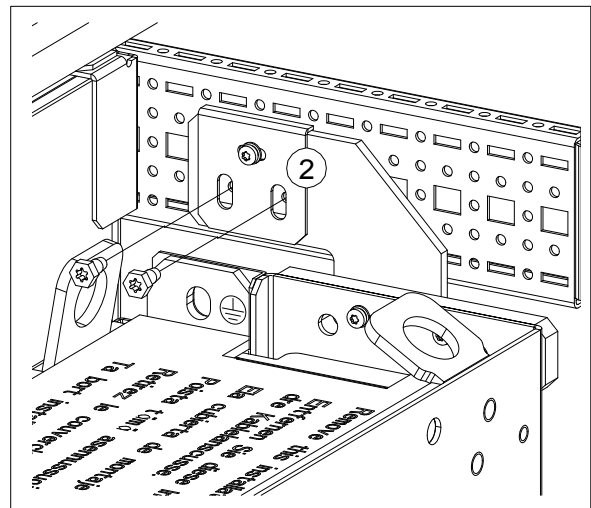
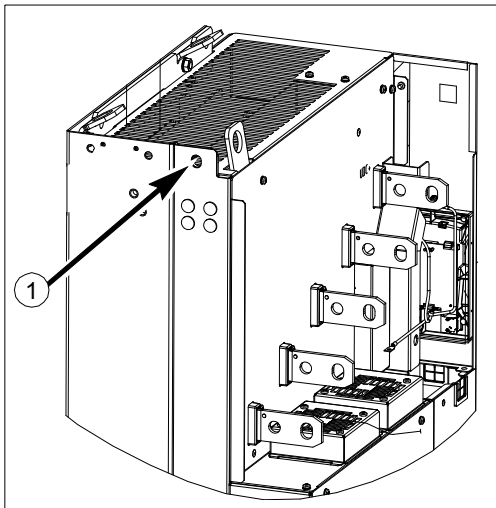

Tapping screw M6x12 Torx T30 (Hex) 9 N·m



■ Installing the bottom grille (for IP20 degree protection)

For option +B051: If IP20 degree of protection is needed from the bottom side, install the bottom grille as shown below.

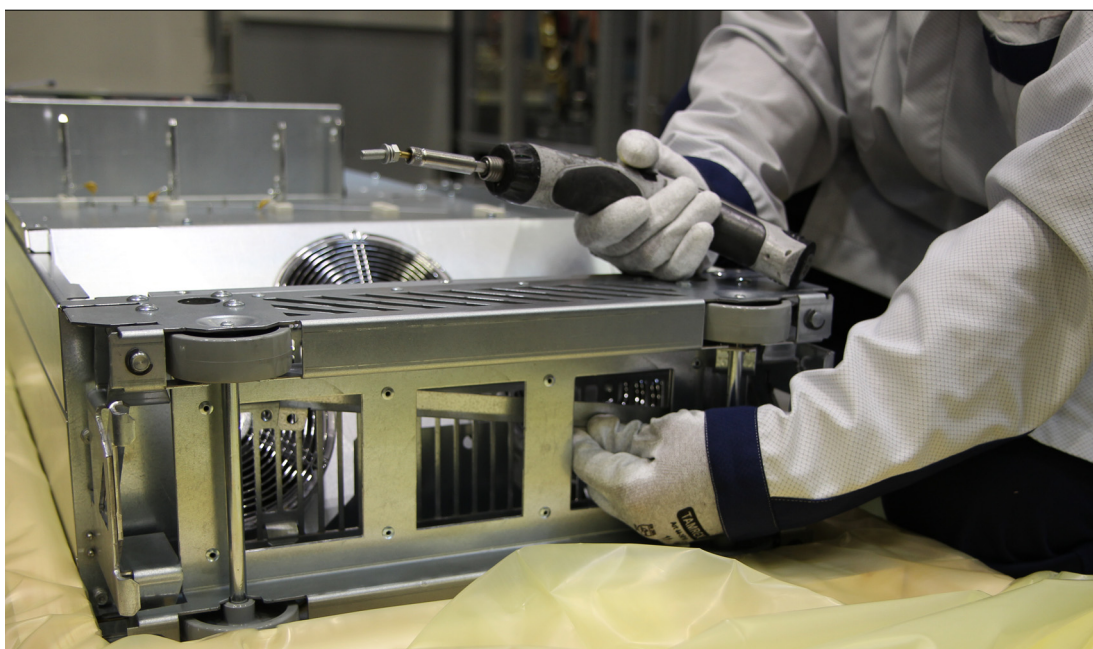
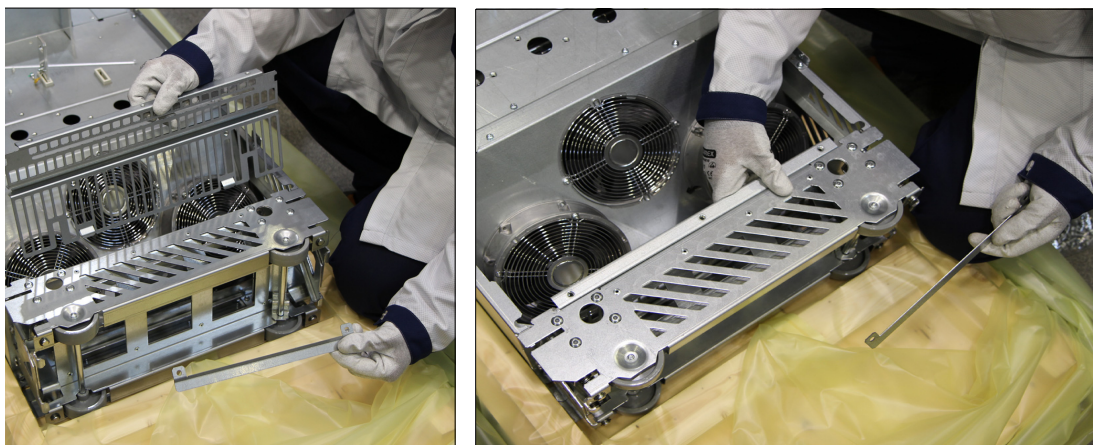

Insert lifting hooks to the drive module lifting eyes and lift the module to the installation place.

Connecting the power cables

■ Connection diagram

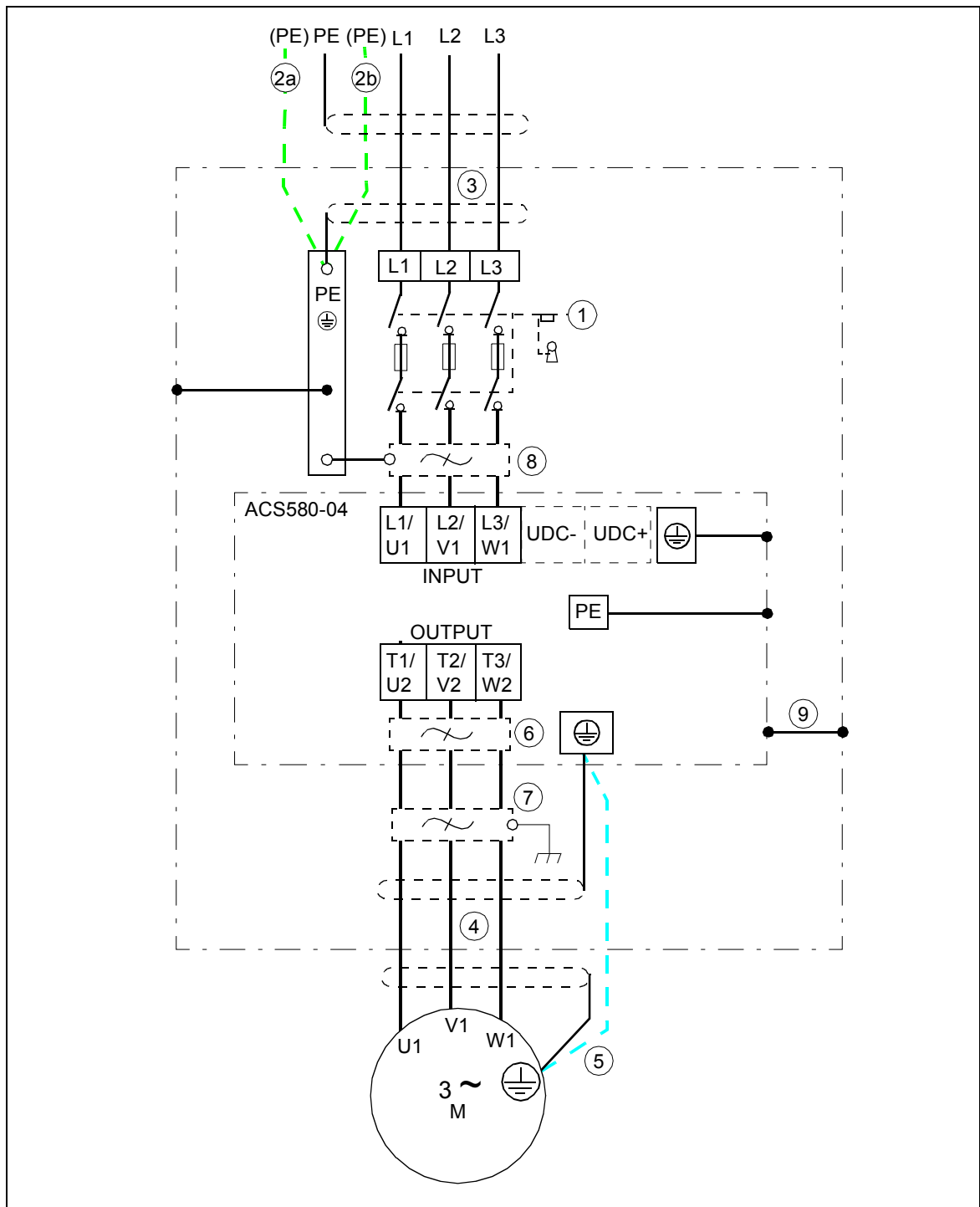

- 1 For alternatives, see section [Selecting the supply disconnecting device](#) on page 52. In the installing example of this chapter, the disconnecting device is not in the same cubicle with the drive module.
- 2 If a shielded cable is used (not required but recommended) and the conductivity of the shield is < 50% of the conductivity of the phase conductor, use a separate PE cable (2a) or a cable with a grounding conductor (2b).
- 3 We recommend 360-degree grounding at the cabinet entry if a shielded cable is used. Ground the other end of the input cable shield or PE conductor at the distribution board.
- 4 We recommend 360-degree grounding at the cabinet entry, see page 42.

- 5 Use a separate grounding cable if the conductivity of the cable shield is < 50% of the conductivity of the phase conductor and there is no symmetrically constructed grounding conductor in the cable (see page 58).
- 6 Common mode filter (optional, see page 53)
- 7 du/dt filter (optional, see page 173)
- 8 EMC filter (option +E210)
- 9 The drive module frame must be connected to the cabinet frame. See section *Arranging the grounding inside the cabinet* on page 41 and *Alternatives for grounding the drive module* on page 77.

Note:

If there is a symmetrically constructed grounding conductor in the motor cable in addition to the conductive shield, connect the grounding conductor to the grounding terminal at the drive and motor ends.

Do not use an asymmetrically constructed motor cable. Connecting its fourth conductor at the motor end increases bearing currents and causes extra wear.

■ Power cable connection procedure



WARNING! Obey the safety instructions in chapter *Safety instructions*. If you ignore them, injury or death, or damage to the equipment can occur.



WARNING! Apply grease to stripped aluminum conductors before attaching them to non-coated aluminum cable lugs. Obey the grease manufacturer's instructions. Aluminum-aluminum contact can cause oxidation in the contact surfaces



1. Run the motor cables from the motor to the cabinet. We recommend to ground the cable shields 360° at the lead-through plate.

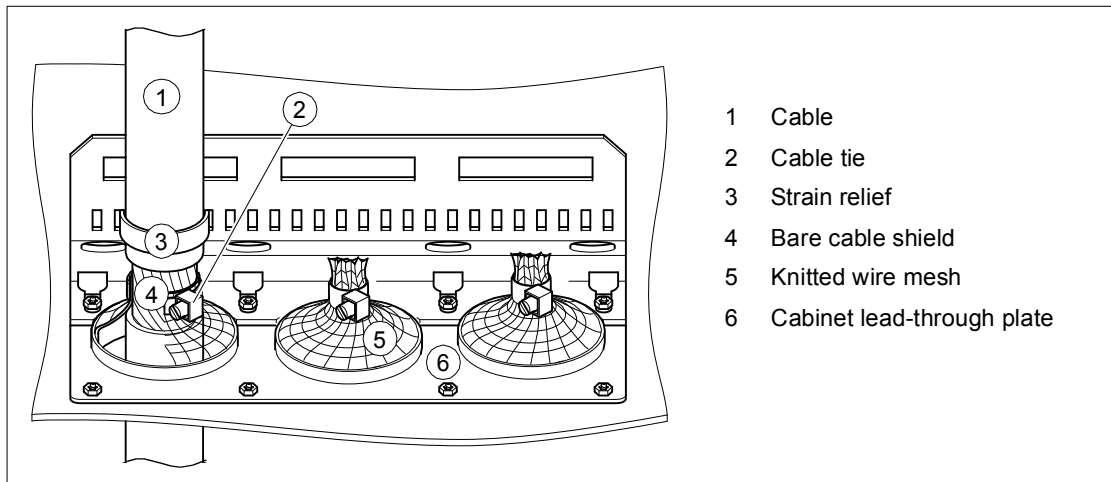

- Twist the cable shields of the motor cables into bundles and connect them and any separate ground conductors or cables to the grounding terminal of the drive module.

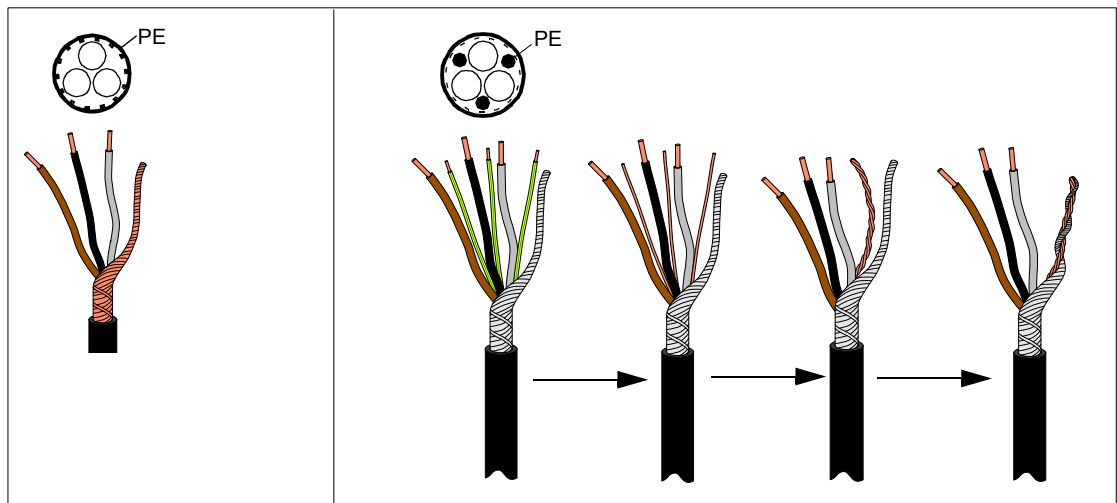

- Connect the phase conductors of the motor cables to terminals T1/U2, T2/V2 and T3/W2 of the drive module. For the tightening torques, see page [119](#).
- Make sure that all power is disconnected and reconnection is not possible. Use proper safe disconnect procedures according to local codes.
- Run the input cables from the supply source to the cabinet. If shielded cable is used: we recommend to ground the cable shields 360° at the lead-through plate.
- If shielded cable is used: twist the cable shields of the input cables into bundles and connect them and any separate ground conductors or cables to the drive module grounding terminal.
- Connect the phase conductors of the input cables to terminals L1/U1, L2/V1 and L3/W1 of the drive module. For the tightening torques, see page [119](#).

■ DC connection

The UDC+ and UDC– terminals are intended for common DC configurations of a number of drives, allowing regenerative energy from one drive to be utilized by the other drives in the motoring mode. For more information, contact your local ABB representative.



Connecting the control cables

1. Remove the middle front cover of the drive module.

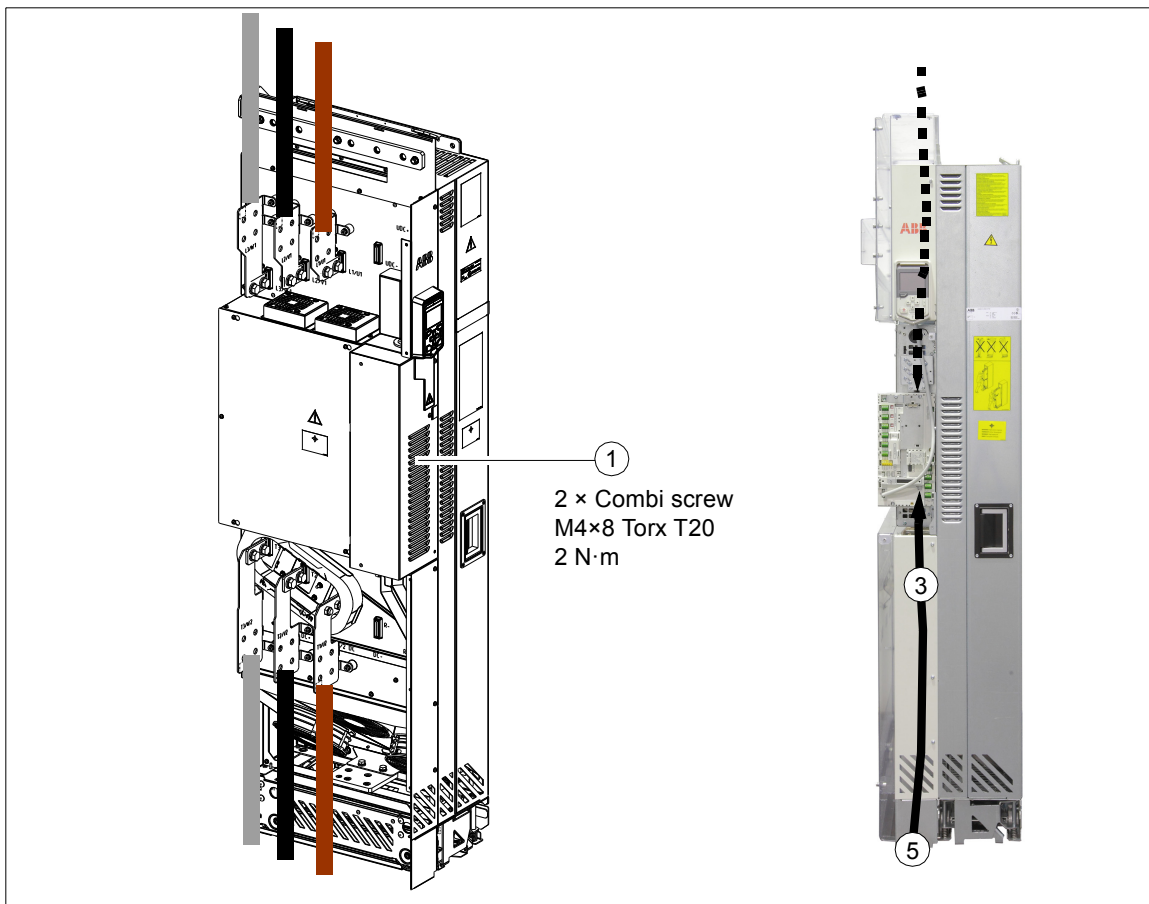

2. Attach the option modules if not attached already. See section [Installing option modules](#) on page [89](#).
3. Lead the control cables inside the drive cabinet.
4. Ground the outer control cable shields 360 degrees at the cabinet lead-through plate (recommendation).
5. Route the control cables along the control cable duct from bottom or top to the control unit.

6. Ground the shields of the control cables at the clamp plate. The shields should be continuous as close to the terminals of the control unit as possible. Only remove the outer jacket of the cable at the cable clamp so that the clamp presses on the bare shield. The shield (especially in case of multiple shields) can also be terminated with a lug and fastened with a screw at the clamp plate. Leave the other end of the shield unconnected or ground it indirectly via a few nanofarads high-frequency capacitor, eg, 3.3 nF / 630 V. The shield can also be grounded directly at both ends if they are *in the same ground line* with no significant voltage drop between the end points. Tighten the screws to secure the connection.

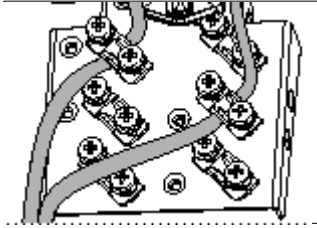

7. Connect the conductors to the appropriate detachable terminals of the control unit. See section [Default I/O connection diagram \(ABB standard macro\)](#) on page 84 for the default I/O connections of the ABB standard macro. For other macros, see the firmware manual. Use shrink tubing or insulating tape to contain any stray strands. Tighten the screws to secure the connection.
Note: Keep any signal wire pairs twisted as close to the terminals as possible. Twisting the wire with its return wire reduces disturbances caused by inductive coupling.



Default I/O connection diagram (ABB standard macro)

Default control connections for the HVAC are shown below.

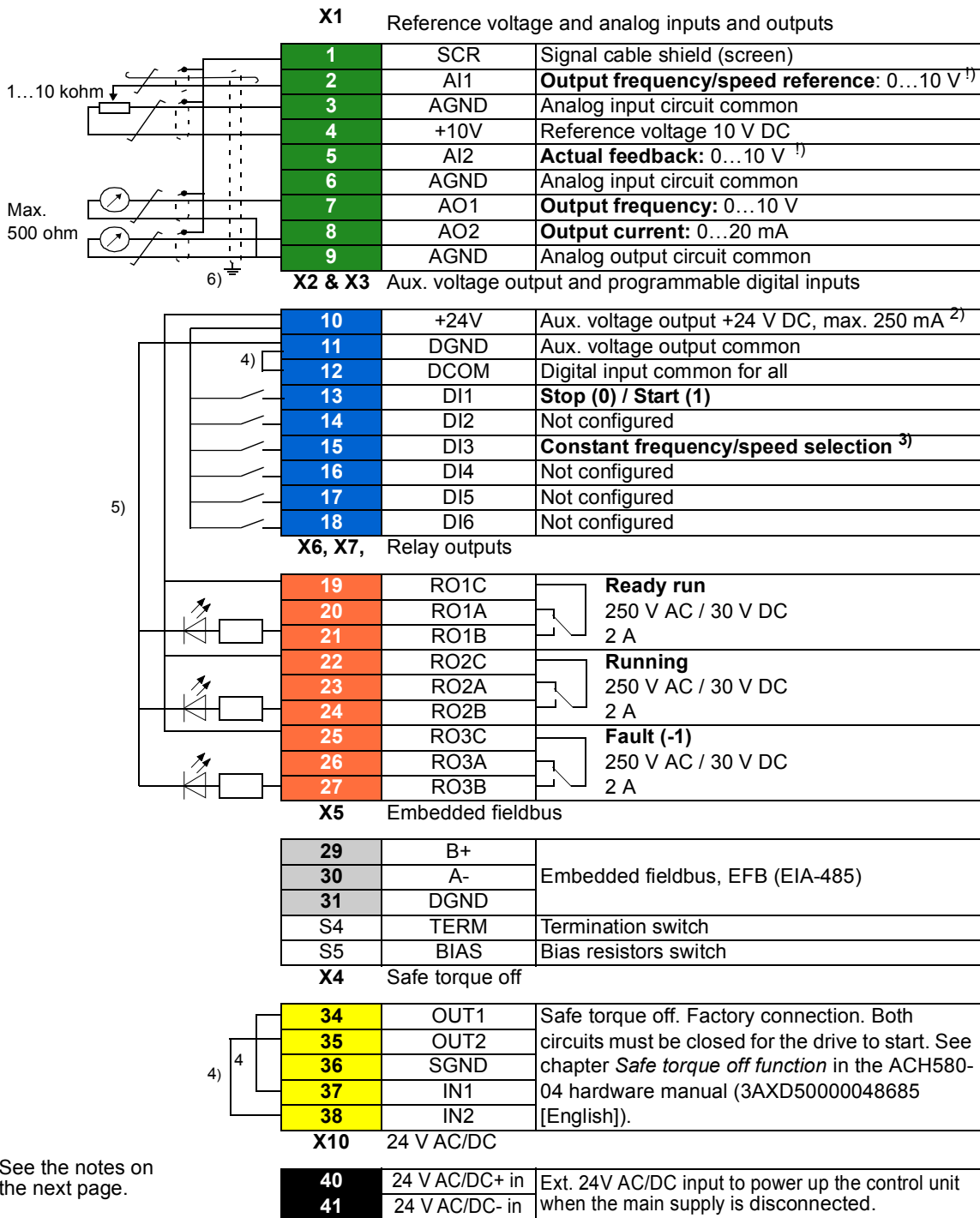

Total load capacity of the Auxiliary voltage output +24V (X2:10) is 6.0 W (250 mA / 24 V DC).

Terminal sizes: 0.14...2.5 mm² (all terminals)





Tightening torques: 0.5...0.6 N·m (0.4 lbf·ft)

Notes:

1. Current [0(4)...20 mA, $R_{in} = 100 \text{ ohm}$] or voltage [0(2)...10 V, $R_{in} > 200 \text{ kohm}$]. Change of setting requires changing the corresponding parameter.
2. Total load capacity of the Auxiliary voltage output +24V (X2:10) is 6.0 W (250 mA / 24 V) minus the power taken by the option modules installed on the board.
3. In scalar control: See Menu - Primary settings - Drive - Constant frequencies or parameter group 28 Frequency reference chain.
In vector control: See Menu - Primary setting - Drive - Constant speeds or parameter group 22 Speed reference selection.
4. Connected with jumpers at the factory.
5. Use shielded twisted-pair cables for digital signals.
Ground the outer shield of the cable 360 degrees at the cabinet entry.

Further information on the usage of the connectors and switches is given in the sections below.

Switches

Switch	Description	Position	
TERM	Drive-to-drive link termination. Must be set to the terminated (ON) position when the drive (or another device) is the first or last unit on the link.		Bus not terminated (default)
			Bus terminated
BIAS	Switches on the biasing voltages to the bus. One (and only one) device, preferably at the end of the bus must have the bias on.		Bias off (default)
			Bias on



PNP configuration for digital inputs (X2 & X3)

Internal and external +24 V power supply connections for PNP configuration are shown in the figure below.

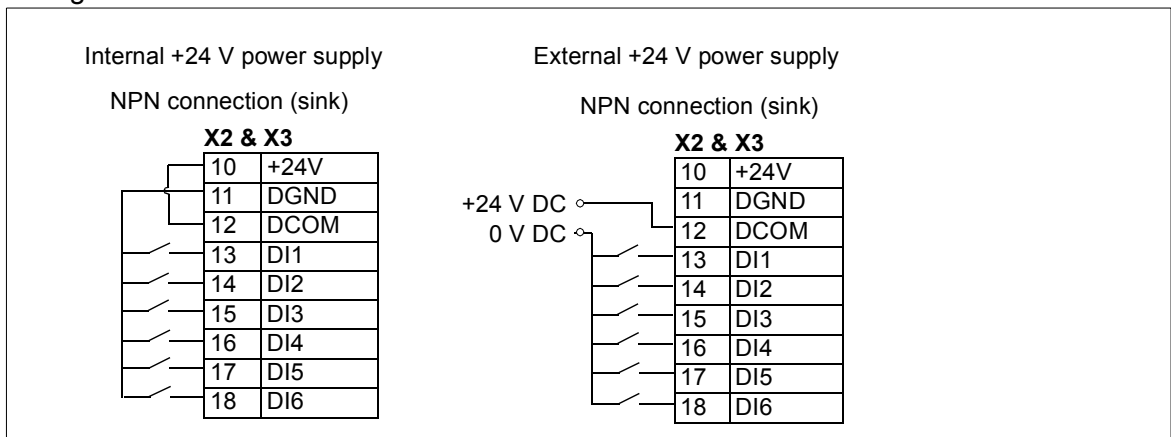

WARNING! Do not connect the +24 V AC cable to the control board ground when the control board is powered using an external 24 V AC supply.

NPN configuration for digital inputs (X2 & X3)

Internal and external +24 V power supply connections for NPN configuration are shown in the figure below.

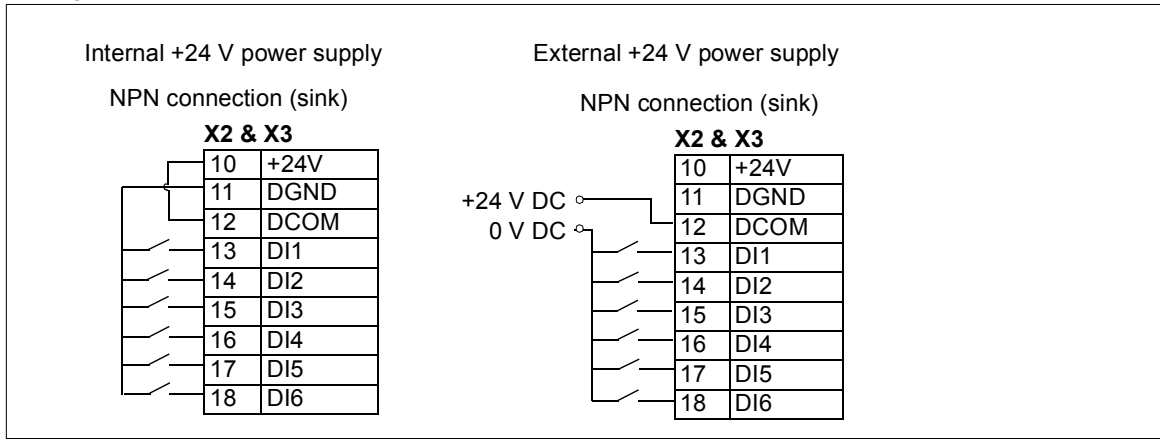

WARNING! Do not connect the +24 V AC cable to the control board ground when the control board is powered using an external 24 V AC supply.

Connection for obtaining 0...10 V from analog output 2 (AO2)

To obtain 0...10 V from analog output AO2, connect a 500 ohm resistor (or two 1 kohm resistors in parallel) between the analog output 2 AO2 and analog common ground AGND.

Examples are shown in the figure below.

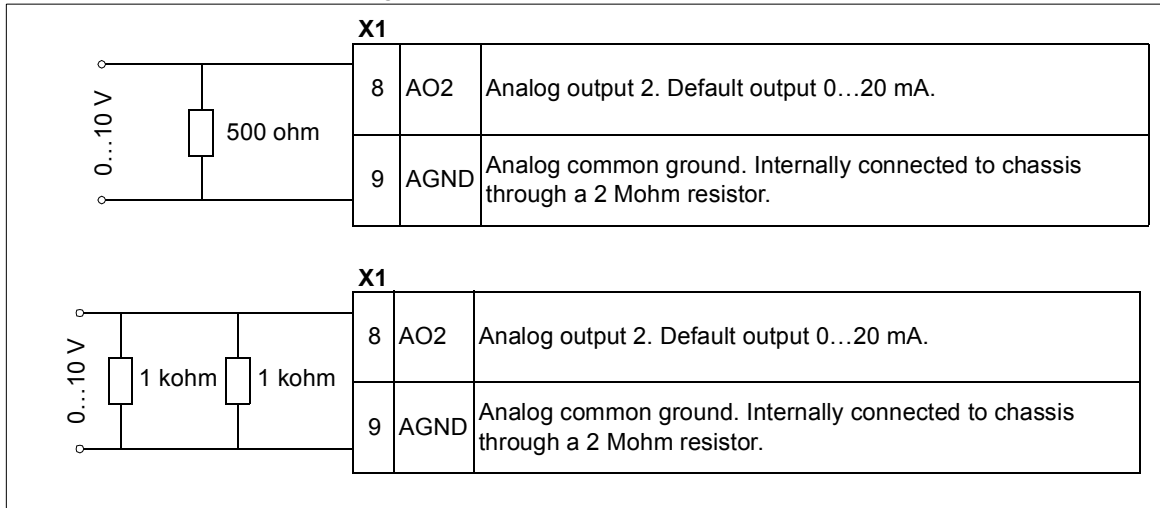

Connection examples of two-wire and three-wire sensors to analog input (AI2)

Note: The maximum capability of the auxiliary voltage output (24 V DC [250 mA]) must not be exceeded.

An example of a two-wire sensor/transmitter supplied by the drive auxiliary voltage output is shown below. Set the input signal to 4...20 mA, not 0...20 mA.

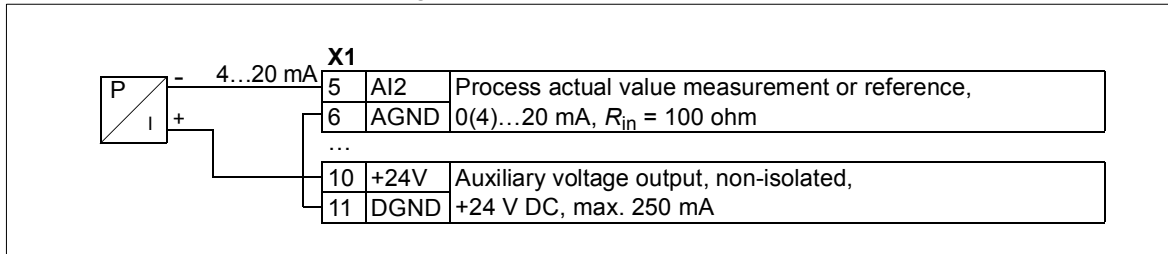

An example of a three-wire sensor/transmitter supplied by the drive auxiliary voltage output is shown below. The sensor is supplied through its current output and the drive feeds the supply voltage (+24 V DC). Thus the output signal must be 4...20 mA, not 0...20 mA.

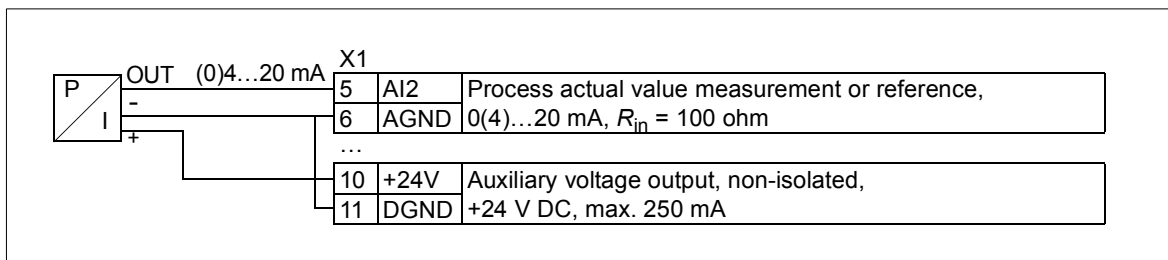

DI6 as frequency input

If DI6 is used as a frequency input, see the firmware manual for how to set parameters accordingly.

DI6 as PTC input

If DI6 is used as a PTC input, see firmware manual for how to set parameters accordingly. The wiring and the PTC sensor need to be double isolated. Otherwise the CMOD-02 I/O extension module must be used.

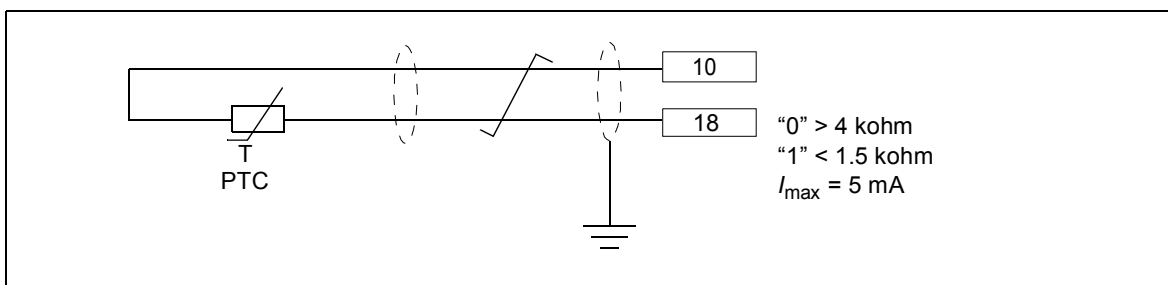

AI1 and AI2 as Pt100, Pt1000, Ni1000, KTY83 and KTY84 sensor inputs (X1)

One, two or three Pt100 sensors; one, two or three Pt1000 sensors; or one Ni1000, KTY83 or KTY84 sensor for motor temperature measurement can be connected between an analog input and output as shown below. Leave the other end of the shield unconnected or ground it indirectly via a few nanofarads high-frequency capacitor, for example, 3.3 nF / 630 V. The shield can also be grounded directly at both ends if they are in the same ground line with no significant voltage drop between the end points.

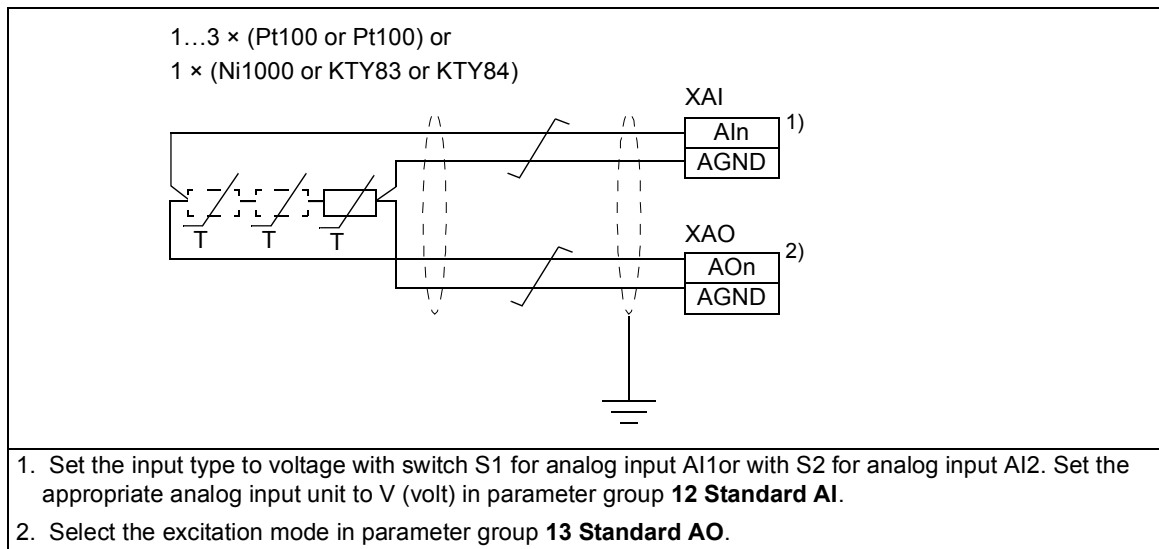

WARNING! As the inputs pictured above are not insulated according to IEC 60664, the connection of the motor temperature sensor requires double or reinforced insulation between motor live parts and the sensor. If the assembly does not fulfill the requirement, the I/O board terminals must be protected against contact and must not be connected to other equipment or the temperature sensor must be isolated from the I/O terminals.

Safe torque off (X4)

For the drive to start, both connections (+24 V DC to IN1 and +24 V DC to IN2) must be closed. By default, the terminal block has jumpers to close the circuit.

Remove the jumpers before connecting an external Safe torque off circuitry to the drive. See also chapter [Safe torque off function](#) on page 139.

Note: Only 24 V DC can be used for STO. Only PNP input configuration can be used.

Connecting a control panel

With door mounting kit (option +J410), connect the control panel to the control unit as shown in *DPMP-02/03 mounting platform for control panels Installation guide* (3AUA0000136205 [English]).

Note 1: When a PC is connected to the control panel, the control panel keypad is disabled. In this case, the control panel acts as a USB-RS485 adapter.

Installing option modules

Disconnect the drive from the power line. Lock the main disconnecting device and ensure by measuring that there is no voltage.

■ Option slot 2 (I/O extension modules)

1. Put the module carefully into its position on the control unit.
2. Tighten the mounting screw.
3. Tighten the grounding screw (CHASSIS). **Note:** The screw grounds the module. It is necessary for fulfilling the EMC requirements and for proper operation of the module.

■ Option slot 1 (fieldbus adapter modules)

1. Put the module carefully into its position on the control unit.
2. Tighten the mounting screw (CHASSIS). **Note:** The screw tightens the connections and grounds the module. It is necessary for fulfilling the EMC requirements and for proper operation of the module.

■ Wiring the optional modules

See the appropriate optional module manual for specific installation and wiring instructions.



Connecting a PC



WARNING! Do not connect the PC directly to the control panel connector of the control unit as this can cause damage.

To be able to connect a PC to the drive, you need an assistant control panel (ACS-AP-x or ACH-AP-H). It is also possible to use CCA-01 configuration adapter.

To connect a PC to the control panel with a USB data cable (USB Type A <-> USB Type Mini-B):

1. Lift the USB connector cover on the control panel from bottom upwards.
2. Insert the USB cable Mini-B plug in the control panel USB connector.
3. Insert the USB cable A-plug in the USB connector of the PC (a). -> The panel displays: USB connected (b).

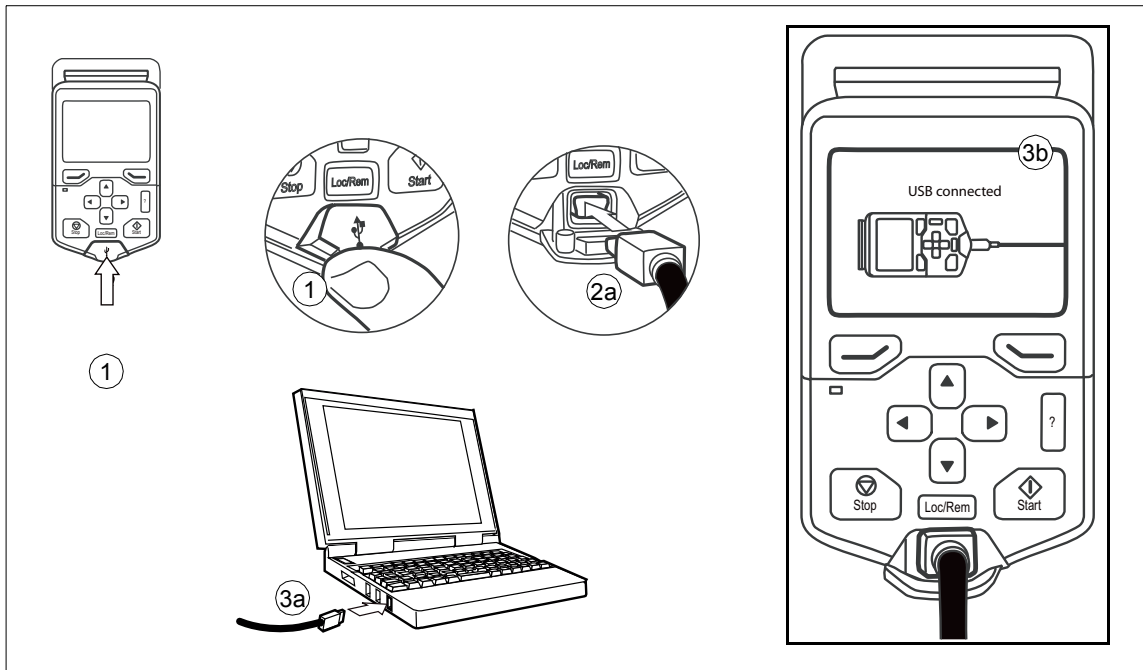

Note: When a PC is connected to the control panel, the control panel keypad is disabled. In this case, the control panel acts as a USB-RS485 adapter.

For information on using the Drive composer PC tool, see *Drive composer PC tool user's manual* (3AUA0000094606 [English]).

7

Installation example of drive module with IP20 shrouds (option +B051)



Contents of this chapter

In this chapter, the drive module with IP20 shrouds (option +B051) is installed in a 600 mm wide Rittal TS 8 cabinet in a bookshelf way of mounting. The module is placed in an upright position on the cabinet bottom with its front facing the cabinet door.

Limitation of liability

Always obey the general rules given in this chapter and local laws and regulations. ABB does not assume any liability whatsoever for any installation which breaches local laws and/or other regulations.

Safety



WARNING! If you are not a qualified electrician do not do the installation work described in this chapter. Obey the instructions in chapter [Safety instructions](#). If you ignore them, injury or death, or damage to the equipment can occur.

Required parts

Drive module standard parts		
<ul style="list-style-type: none"> • Drive module • Fastening bracket • Pedestal guide plate • Telescopic extraction and insertion ramp • Fastening screws and insulators in a plastic bag • External control unit 		
Rittal parts		
Rittal part code	Qty (pcs)	Description
TS 8606.500	1	Enclosure without mounting plate, bottom plates and side panels.
TS 8612.160	5	Punched section with mounting flange, outer mounting level for 600 mm horizontal
TS 4396.500		Support rails
SK 3243.200	4	Air filter 323 mm × 323 mm. Remove the filter mats.
Customer-made parts (not ABB or Rittal products)		
Air baffles	2	See section Preventing the recirculation of hot air on page 45 and section Air baffles for the drive module with option +B051 on page 136.

Required tools

- Set of screw drivers (Torx and Pozidriv)
- Set of metric magnetic-end hexagon sockets
- Torque wrench
- Step drill bit for drilling the holes in the clear plastic shroud for input power cables.



Overall flowchart of the installation process



Step	Task	For instructions, see
1	Install the Rittal parts, drive bottom guide plate and loose drive options in the drive module cubicle.	Installing the drive module into a cabinet on page 93 and installation drawings on page 175 .
2	Install the auxiliary components (such as mounting plates, air baffles, switches, busbars etc.).	The component manufacturer's instructions Preventing the recirculation of hot air on page 45.
	Attach the drive module to the cabinet	Step-by-step drawings for an installation example of drive module with options +B051 and +E208 in Rittal TS 8 600 mm wide cabinet on page 175 .
3	Connect the power cables and clear plastic shrouds to the drive module.	Connecting the power cables and installing the shrouds on page 93
6	Connect the control cables.	Connecting the control cables , page 82
7	Install the remaining parts, for example, cabinet doors, side plates, etc.	The component manufacturer's instructions. Installing the roof and door on page 95

Installing the drive module into a cabinet

See appendix [Step-by-step drawings for an installation example of drive module with options +B051 and +E208 in Rittal TS 8 600 mm wide cabinet](#) on page 175 and ACS580-04 quick installation guide (3AXD50000015469 [English]).

- Install the punched section to the back of the cabinet frame.
- Install the support rails and pedestal guide plate to the cabinet bottom frame.
- Install the telescopic insertion ramp to the pedestal guide plate.
- Remove the sheeting from the clear plastic shrouds from both sides.
- Install the top metallic shroud to the drive module.
- Install the back shrouds to the drive module.
- To prevent the drive module from falling, attach its lifting lugs with chains to the cabinet frame.
- Push the drive module carefully into the cabinet along the telescopic insertion ramp.
- Remove the ramp.
- Fasten the drive module to the pedestal guide plate.
- Fasten the drive module from top to the punched section at the cabinet back. **Note:** The fastening bracket grounds the drive module to the cabinet frame.
- Install the air baffles. See section [Preventing the recirculation of hot air](#) on page 45.



Connecting the power cables and installing the shrouds

Step	Task (motor cables)
1	Install the grounding terminal to the drive module base.
2	Run the motor cables to the cabinet. Ground the cable shields 360 degrees at the cabinet lead-through
3	Connect the twisted shields of the motor cables to the grounding terminal
4	<p>Screw in and tighten the insulators to the drive module by hand. Install the T3/W2 connection terminal to the insulators.</p> <p> WARNING! Do not use longer screws or bigger tightening torque than given in the installation drawing. They can damage the insulator and cause dangerous voltage to be present at the module frame.</p> <p></p>
5	Connect the phase T3/W2 conductors to the T3/W2 terminal.
6	Install the T2/V2 connection terminal to the insulators See the warning in step 4.
7	Connect the phase T2/V2 conductors to the T2/V2 connection terminal.
8	Install the T1/U2 connection terminal to the insulators. See the warning in step 4.
9	Connect the phase T1/U2 conductors to the T1/U2 terminal.
10	Remove the plastic sheeting from the output clear plastic shroud from both sides.
11	Install the shroud to the drive module.
12	Install the lower front cover to the drive module.

Step	Task (input cables)
1	Ground the input cable shields (if present) 360 degrees at the cabinet lead-through.
2	Connect the twisted shields of the input cables and separate ground cable (if present) to the cabinet grounding busbar.



94 Installation example of drive module with IP20 shrouds (option +B051)

Step	Task (input cables)
3	Step drill carefully sufficiently big holes to the lead-through clear plastic shroud for the cables to be connected. Align the holes in the vertical direction according to the alignment holes in the shroud. Smooth the hole edges. Remove the plastic sheeting from both sides of the shroud. Attach the cables firmly to the cabinet frame to prevent chafing against the hole edges.
4	Put the conductors of the input cables through the drilled holes in the clear plastic shroud.
5	<u>For drive modules without option +H370:</u> Connect the input cable conductors to the drive module L1/U1, L2/V1 and L3/W1 connection busbars, Go to step 12.
For option +H370: Do steps 6 to 11.	
6	Screw in and tighten the insulators to the drive module by hand. Install the L1/U1 connection terminal to the insulators.  WARNING! Do not use longer screws or bigger tightening torque than given in the installation drawing. They can damage the insulator and cause dangerous voltage to be present at the module frame. 
7	Connect the L1/U1 conductors to the L1/U1 connection terminal.
8	Install the L2/V1 connection terminal to the insulators. See the warning in step 5.
9	Connect the L2/V1 conductors to the L2/V1 connection terminal.
10	Install the L3/W1 connection terminal to the insulators. See the warning in step 5.
11	Connect the L3/W1 conductors to the L3/W1 connection terminal.
12	Install the lead-through clear plastic shroud. Install the front clear plastic shroud and upper front cover. Remove the cardboard protective covering from the drive module air outlet.
13	Install the side and top clear plastic shrouds to the drive module.



Installing the roof and door

Install the air inlet gratings to the cabinet door and the spacers on top of the cabinet as shown below.

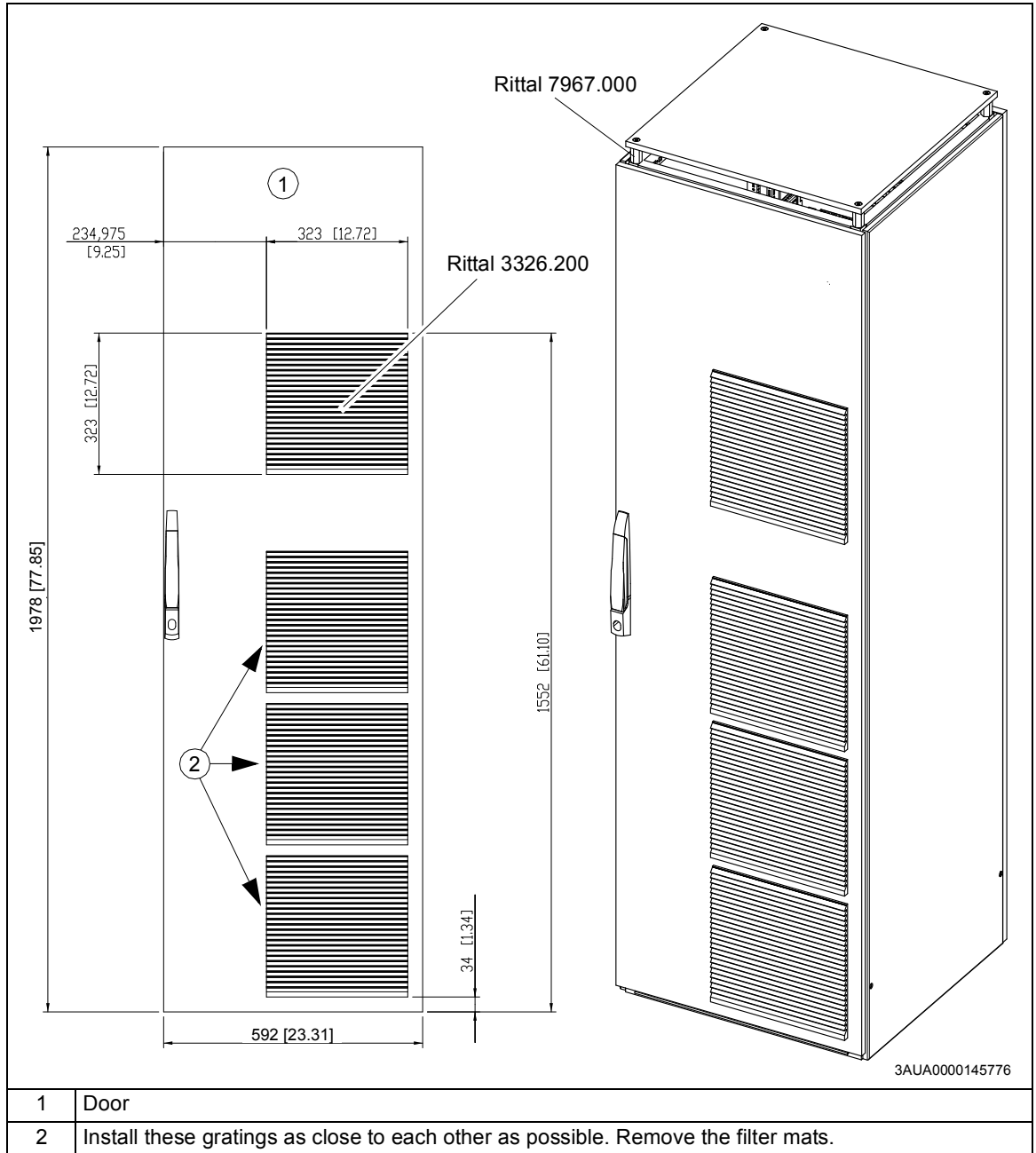

Miscellaneous

■ Input power cable lead-through from top

If you run the input cables from top to the drive module, drill the lead-through holes to the top clear plastic shroud.

■ Attaching the drive module to a mounting plate

Use the assembly support if you attach the drive module directly to the cabinet back plate. The support prevents the drive module screws from chafing the plate.

■ IP20 shrouds

You can order IP20 shrouds for frame R10 with code 3AXD50000024563 and for R11 with 3AXD50000024564.

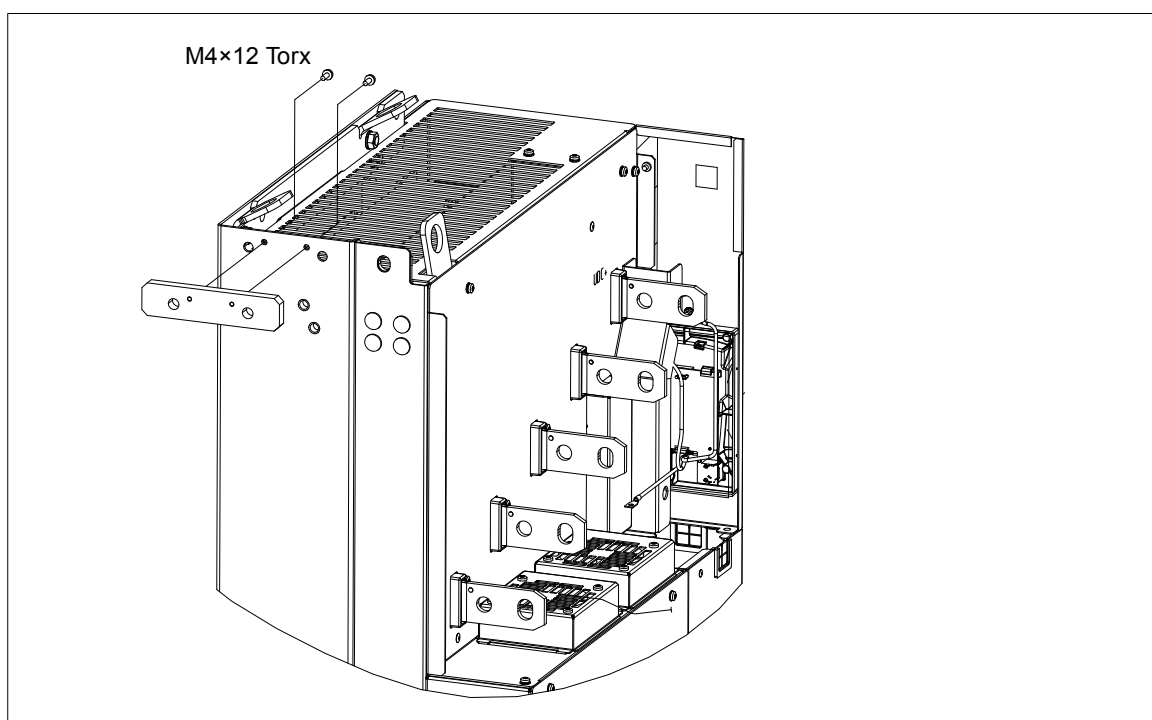

8

Installation checklist

Contents of this chapter

This chapter contains a list for checking the mechanical and electrical installation of the drive module.

Installation checklist

Go through the checklist below together with another person.



WARNING! Obey the safety instructions in chapter [Safety instructions](#). If you ignore them, injury or death, or damage to the equipment can occur.

Check that ...	<input checked="" type="checkbox"/>
Cabinet construction	
The drive module is fastened properly to the cabinet. (See chapters Guidelines for planning the cabinet installation , Installation example of drive module with IP20 shrouds (option +B051) .)	<input type="checkbox"/>
Mechanical joints are tightened and not broken.	<input type="checkbox"/>
Parts are clean and painted surfaces not scratched. The cabinet frame and parts which are in metal to metal contact with the frame (for example seams, component fixing points on assembly plates, back of control unit mounting plate) are not finished with non-conducting paint or material.	<input type="checkbox"/>
Degree of protection (IPxx)	<input type="checkbox"/>

Check that ...	<input checked="" type="checkbox"/>
Drive option modules and other components	
Type and number of option modules and other equipment is correct. Option modules and other equipment are not damaged.	<input type="checkbox"/>
Optional modules and terminals are labelled correctly.	<input type="checkbox"/>
The placement of optional modules and other equipment inside the cabinet and on the cabinet door is correct.	<input type="checkbox"/>
The mounting of optional modules and other equipment is correct.	<input type="checkbox"/>
Internal cabling of the cabinet assembly	
Main circuit: <ul style="list-style-type: none"> • AC supply input cabling is ok. • AC output cabling is ok. 	<input type="checkbox"/>
Cable types, cross-sections, colours and optional markings are correct.	<input type="checkbox"/>
Cabling is not susceptible to interference. Check the twisting of cables and cable routes.	<input type="checkbox"/>
Connection of cables to devices, terminal blocks and drive module circuit boards: <ul style="list-style-type: none"> • Cables are connected to terminals tight enough by pulling the cable. • Cable termination on terminals chaining is done correctly. • Bare conductors are not too far outside the terminal causing an insufficient clearance or loss of shielding against contact. • The control unit is wired properly to the drive module. • The control panel cable is connected properly. 	<input type="checkbox"/>
Cables are not lying against sharp edges or bare live parts. Bending radius of fiber optic cables is at least 3.5 cm (1.38 in.).	<input type="checkbox"/>
The type, markings, insulation plates and cross connections of terminal blocks are correct.	<input type="checkbox"/>
Grounding and protection	
The grounding colors, cross-section and grounding points of modules and other equipment match the circuit diagrams. No long routes for pigtails.	<input type="checkbox"/>
Connections of PE cables and busbars are tight enough. Pull the cable to test that it does not loosen. No long routes for pigtails.	<input type="checkbox"/>
Doors equipped with electrical equipment are grounded. No long grounding routes. From EMC standpoint best result is achieved with a flat copper braid.	<input type="checkbox"/>
Fans that can be touched are shrouded.	<input type="checkbox"/>
Live parts inside the doors are protected against direct contact to at least IP2x.	<input type="checkbox"/>
Labels	
The type designation labels and warning and instruction stickers are made according to the local regulations and placed correctly.	<input type="checkbox"/>
Switches and doors	
Mechanical switches, main disconnecting switch and cabinet doors function properly.	<input type="checkbox"/>

Check that ...	<input checked="" type="checkbox"/>
Installation of the cabinet	
The drive cabinet has been attached to floor and also from top to the wall or roof.	<input type="checkbox"/>
The ambient operating conditions meet the specifications given in chapter <i>Technical data</i> .	<input type="checkbox"/>
The cooling air will flow freely in and out of the drive cabinet, and air recirculation inside the cabinet will not be possible (air baffle plates are on place).	<input type="checkbox"/>
<u>If the drive module has been stored over one year:</u> The electrolytic DC capacitors in the DC link of the drive have been reformed. See page 111.	<input type="checkbox"/>
There is an adequately sized protective ground conductor between the drive and the switchboard.	<input type="checkbox"/>
There is an adequately sized protective ground conductor between the motor and the drive.	<input type="checkbox"/>
All protective ground conductors have been connected to the appropriate terminals and the terminals have been tightened. (Pull the conductors to check.)	<input type="checkbox"/>
The enclosures of the equipment in the cabinet have proper galvanic connection to the cabinet protective earth (ground) busbar; The connection surfaces at the fastening points are bare (unpainted) and the connections are tight, or separate grounding conductors have been installed.	<input type="checkbox"/>
The supply voltage matches the nominal input voltage of the drive. Check the type designation label.	<input type="checkbox"/>
The input power cable has been connected to the appropriate terminals, the phase order is right, and the terminals have been tightened. (Pull the conductors to check.)	<input type="checkbox"/>
Appropriate AC fuses and a main disconnecter have been installed.	<input type="checkbox"/>
The motor cable has been connected to the appropriate terminals, the phase order is right, and the terminals have been tightened. (Pull the conductors to check.)	<input type="checkbox"/>
The motor cable has been routed away from other cables.	<input type="checkbox"/>
No power factor compensation capacitors have been connected to the motor cable.	<input type="checkbox"/>
The control cables (if any) have been connected to the appropriate terminals, and the terminals have been tightened. (Pull the conductors to check.)	<input type="checkbox"/>
<u>If a drive bypass connection is used:</u> The direct-on-line contactor of the motor and the drive output contactor are either mechanically or electrically interlocked, ie, cannot be closed simultaneously.	<input type="checkbox"/>
There are no tools, foreign objects or dust from drilling inside the drive module.	<input type="checkbox"/>
All shrouds and cover of the motor connection box are in place. Cabinet doors have been closed.	<input type="checkbox"/>
The motor and the driven equipment are ready for start.	<input type="checkbox"/>



9

Start-up

Contents of this chapter

This chapter describes the start-up procedure of the drive.

Start-up procedure

1. Only qualified electricians are allowed to start-up the drive.
2. Make sure that the installation of the drive module has been checked according to the checklist in chapter [Installation checklist](#), and that the motor and driven equipment are ready for start.
3. Perform the start-up tasks instructed by the cabinet-installer of the drive module.
4. Switch the power on, setup the drive control program, and perform the first start of the drive and motor. See the *ACH580-04 quick installation* (3AXD50000048686 [English]) or *ACH580 firmware manual* (3AXD50000027537 [English]). If you need more information on the use of the control panel, see *ACS-AP-x Assistant control panels user's manual* (3AUA0000085685 [English]).

For drive modules in which the Safe torque off function is in use: Test and validate the operation of the Safe torque off function. See section [Start-up including acceptance test](#) on page 147.





10

Fault tracing

Contents of this chapter

This chapter describes the fault tracing possibilities of the drive.

Warning and fault messages

See the firmware manual for the descriptions, causes and remedies of the control program warning and fault messages.

11

Maintenance

Contents of this chapter

This chapter contains maintenance instructions of the drive module.

Maintenance intervals

The table below shows the maintenance tasks which can be done by the end user. The complete maintenance schedule is available on the Internet (www.abb.com/drivesservices). For more information, consult your local ABB Service representative (www.abb.com/searchchannels).

The maintenance and component replacement intervals are based on the assumption that the equipment is operated within the specified ratings and ambient conditions. ABB recommends annual drive inspections to ensure the highest reliability and optimum performance.

Note: Long term operation near the specified maximum ratings or ambient conditions may require shorter maintenance intervals for certain components. Consult your local ABB Service representative for additional maintenance recommendations.

■ Descriptions of symbols

Action	Description
I	Visual inspection and maintenance action if needed
P	Performance of on/off-site work (commissioning, tests, measurements or other work)
R	Replacement of component

■ Recommended annual maintenance actions by the user

Target	Action
Connections and environment	
Quality of supply voltage	P
Spare parts	
Spare parts	I
Capacitor reforming, spare modules and spare capacitors	P
Inspections by user	
Tightness of terminals	I
Dustiness, corrosion or temperature	I
Heat sink cleaning	P

■ Recommended maintenance intervals after start-up

Component	Years from start-up						
	3	6	9	12	15	18	21
Cooling							
Main cooling fan							
Main cooling fans			R			R	
Auxiliary cooling fan							
Circuit board compartment cooling fans		R		R		R	
Aging							
Control panel battery			R			R	

4FPS10000309652

Cabinet

■ Cleaning the interior of the cabinet



WARNING! Obey the safety instructions in chapter [Safety instructions](#). If you ignore them, injury or death, or damage to the equipment can occur.



WARNING! Use a vacuum cleaner with antistatic hose and nozzle. Using a normal vacuum cleaner creates static discharges which can damage circuit boards.

1. Stop the drive and do the steps in section [Precautions before electrical work](#) on page [16](#) before you start the work.
2. Make sure that the drive is disconnected from the power line and all other precautions described under [Grounding](#) on page [18](#) have been taken into consideration.
3. When necessary, clean the interior of the cabinet with a soft brush and a vacuum cleaner.

Heatsink

The module heatsink fins pick up dust from the cooling air. The drive runs into overtemperature warnings and faults if the heatsink is not clean.

■ Cleaning the interior of the heatsink



WARNING! Obey the safety instructions in chapter [Safety instructions](#). If you ignore them, injury or death, or damage to the equipment can occur.



WARNING! Use a vacuum cleaner with antistatic hose and nozzle. Using a normal vacuum cleaner creates static discharges which can damage circuit boards.

1. Stop the drive and do the steps in section [Precautions before electrical work](#) on page [16](#) before you start the work.
2. Make sure that the drive is disconnected from the power line and all other precautions described under [Grounding](#) on page [18](#) have been taken into consideration.
3. Undo the fastening screws of the handle plate of the drive module.
4. Remove the handle plate.
5. Vacuum the interior of the heatsink from the opening.
6. Blow clean compressed air (not humid or oily) upwards from the opening and, at the same time, vacuum from the top of the drive module.

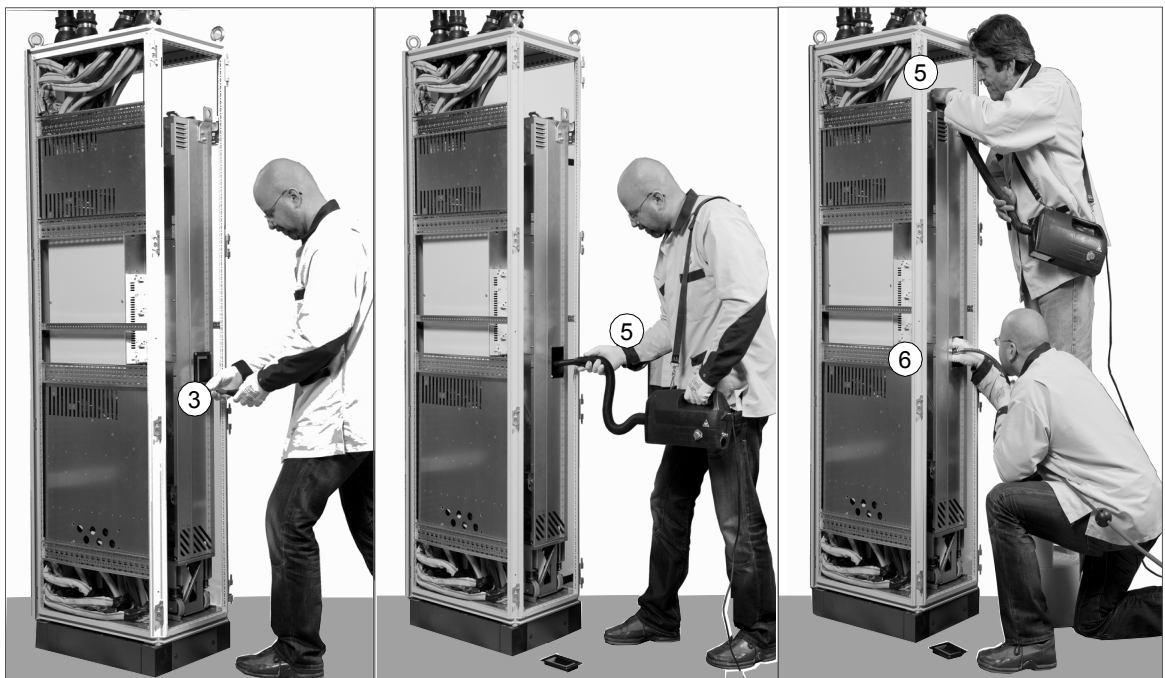

Fans

The actual lifespan depends on the running time of the fan, ambient temperature and dust concentration. See the firmware manual for the actual signal which indicates the running time of the cooling fan. For resetting the running time signal after a fan replacement, please contact ABB.

Replacement fans are available from ABB. Do not use other than ABB specified spare parts.

■ Replacing the circuit board compartment cooling fan



WARNING! Obey the safety instructions in chapter [Safety instructions](#). If you ignore them, injury or death, or damage to the equipment can occur.

1. Stop the drive and do the steps in section [Precautions before electrical work](#) on page [16](#) before you start the work.
2. Remove the drive module out of the cabinet. See section [Replacing the drive module](#) on page [110](#).
3. Undo the fastening screw of the fan enclosure.
4. Unplug the power supply cable of the fan.
5. Install the new fan in reverse order to the above.

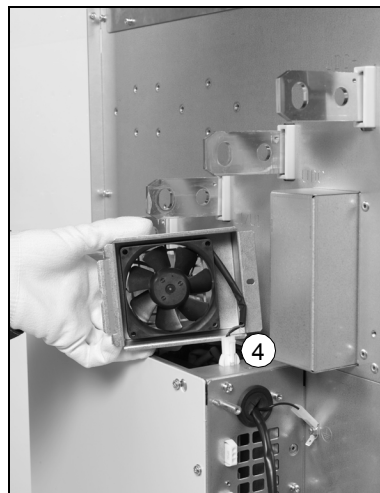

■ Replacing the main cooling fans



WARNING! Obey the safety instructions in chapter [Safety instructions](#). If you ignore them, injury or death, or damage to the equipment can occur.

1. Stop the drive and do the steps in section [Precautions before electrical work](#) on page [16](#) before you start the work.
2. Remove the drive module out of the cabinet. See section [Replacing the drive module](#) on page [110](#).
3. Open the support legs of the pedestal.
4. Undo the two screws that fasten the fan assembly plate.
5. Tilt the fan assembly plate down.
6. Disconnect the power supply wires of the fans.
7. Remove the fan assembly from the drive module.
8. Undo the fastening screws of the fan(s) and remove the fan(s) from the assembly plate.
9. Install the new fan(s) in reverse order to the above.

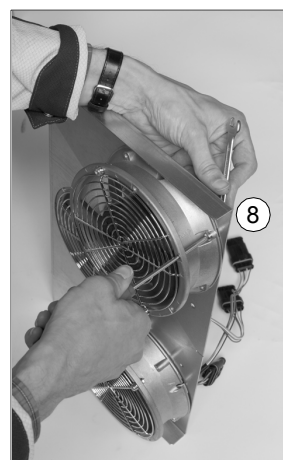
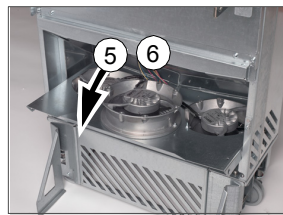

Replacing the drive module



WARNING! Obey the safety instructions in chapter [Safety instructions](#). If you ignore them, injury or death, or damage to the equipment can occur.

- Handle the drive module carefully:
 - Use safety shoes with a metal toe cap to prevent foot injury.
 - Lift the drive module only by the lifting lugs.
 - Make sure that the module does not topple over when you move it on the floor: Open the support legs by pressing each leg a little down (1, 2) and turning it aside. Whenever possible secure the module also with chains.
 - Do not tilt the drive module (A). It is **heavy** and its **center of gravity is high**. The module overturns from a sideways tilt of 5 degrees. Do not leave the module unattended on a sloping floor.

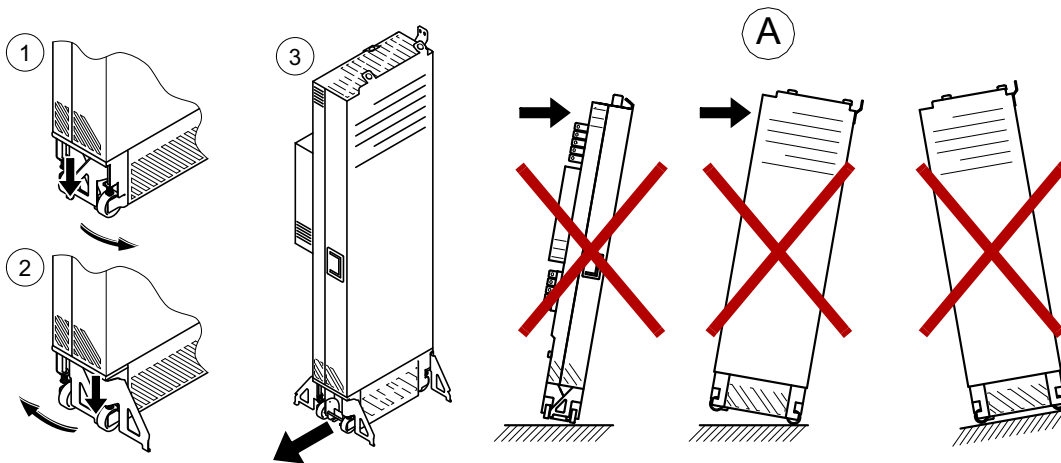

1. Stop the drive and do the steps in section [Precautions before electrical work](#) on page [16](#) before you start the work.
2. Make sure that all other precautions described under [Grounding](#) on page [18](#) have been taken into consideration.
3. For option +B051, remove the clear plastic shrouds on the power cables and parts in front of the drive module.
4. Disconnect the power cables.
5. Disconnect the external control cables from the drive module.
6. Remove the screws that attach the drive module to the cabinet at the top and behind the front support legs.
7. Attach the extraction ramp to the cabinet base with two screws.
8. To prevent the drive module from falling, attach its top lifting lugs with chains with chains to the cabinet frame.
9. Pull the drive module carefully out of the cabinet preferably with help from another person.
10. Install the new module in reverse order to the above.

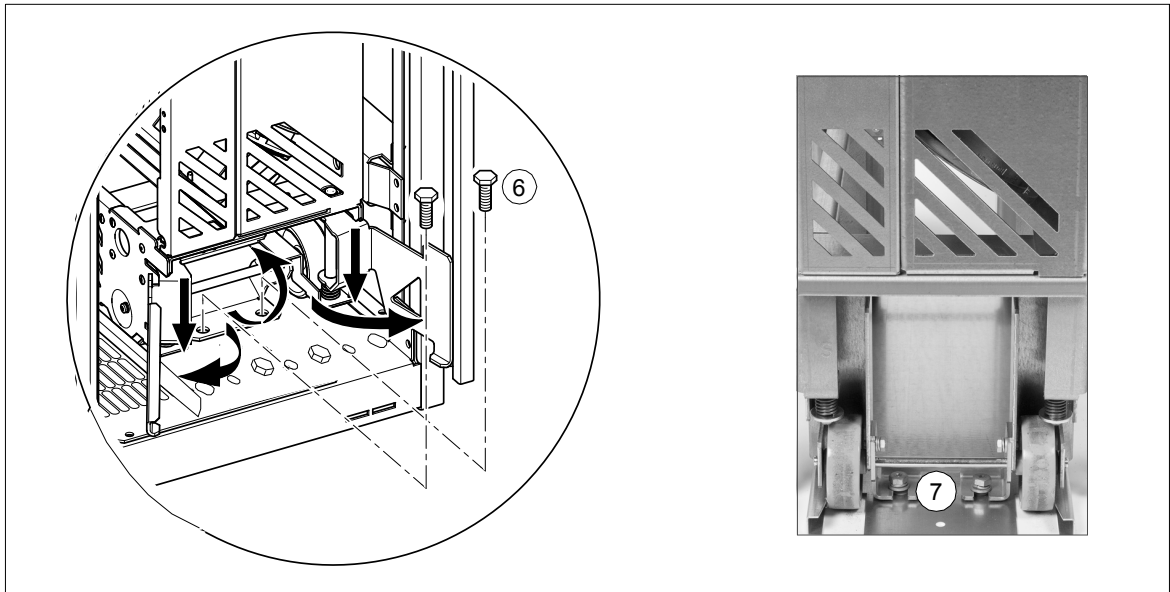

Capacitors

The drive intermediate circuit employs several electrolytic capacitors. Their lifespan depends on the operating time of the drive, loading and ambient temperature. The lifespan of the capacitor can be prolonged by lowering the ambient temperature.

It is not possible to predict a capacitor failure. The capacitor failure is usually followed by damage to the unit and an input cable fuse failure, or a fault trip. Contact ABB if a capacitor failure is suspected. Replacements are available from ABB. Do not use other than ABB specified spare parts.

■ Reforming the capacitors

If the drive module has been stored for a year or more, reform the capacitors. See page [33](#) for information on finding out the manufacturing date. For the reforming instructions, see *Converter modules with electrolytic DC capacitors in the DC link, capacitor reforming instructions* (3BFE64059629 [English]).

Control panel

■ Cleaning the control panel

Use a soft damp cloth to clean the control panel. Avoid harsh cleaners which could scratch the display window.

■ Replacing the battery in the assistant control panel

A battery is only used in assistant control panels that have the clock function. The battery keeps the clock operating in memory during power interruptions.

The expected life for the battery is greater than ten years.

Note: The battery is NOT required for any control panel or drive functions, except the clock.

1. Remove the control panel from the drive.
Press the retaining clip at the top (1a) and pull it forward from the top edge (1b).

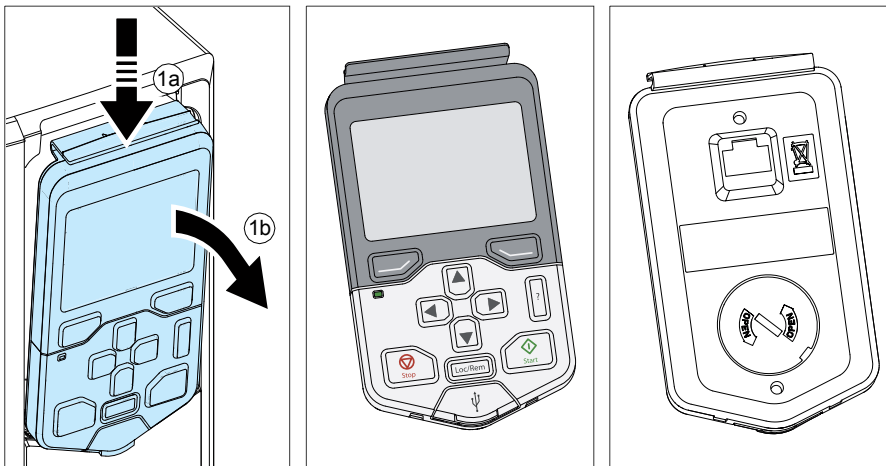

2. To remove the battery, use a coin to rotate the battery cover on the back of the control panel.

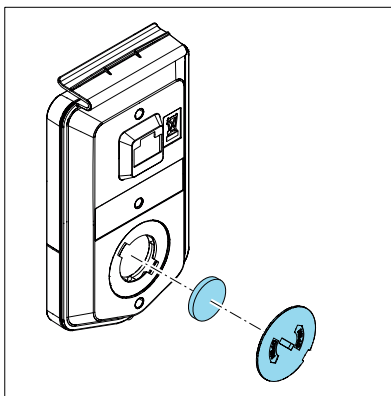

3. Replace the battery with type CR2032. Dispose the old battery according to local disposal rules or applicable laws.

4. To reinstall the control panel, put the bottom of the container in position (4a), press the retaining clip at the top (4b) and push the control panel in at the top edge (4c).

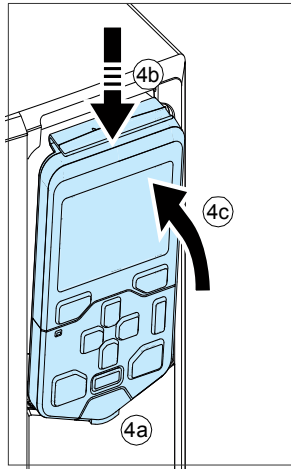

For the use of the control panel, see the firmware manual and *ACS-AP-X assistant control panels user's manual* (3AUA0000085685 [English]).



12

Technical data

Contents of this chapter

This chapter contains the technical specifications of the drive, for example, the ratings, sizes and technical requirements, provisions for fulfilling the requirements for CE and other markings.

Ratings

The ratings of the drive modules with 50&60 Hz supply are given below.

■ IEC ratings

IEC RATINGS									
Drive type ACH580-04-	Frame size	Input current	Output ratings						
			Nominal use			Light-duty use		Heavy-duty use	
		I_1 A	I_{max} A	I_2 A	P_N kW	I_{Ld} A	P_{Ld} kW	I_{Hd} A	P_{Hd} kW
$U_N = 380...415 \text{ V (380, 400, 415 V)}$									
505A-4	R10	505	560	505	250	485	250	361	200
585A-4	R10	585	730	585	315	575	315	429	250
650A-4	R10	650	730	650	355	634	355	477	250
725A-4	R11	725	1020	725	400	715	400	566	315
820A-4	R11	820	1020	820	450	810	450	625	355
880A-4	R11	880	1100	880	500	865	500	725*	400

3AXD00000586715

See definitions and notes on page [116](#).

NEMA ratings

NEMA RATINGS							
Drive type ACH580-04-	Frame size	Input current	Output ratings				
			Nominal use	Light-duty use		Heavy-duty use	
			I_1	I_{max}	I_{Ld}	P_{Ld}	I_{Hd}
A							
A							
hp							
A							
hp							
$U_N = 440...480$ V (440, 460, 480 V)							
505A-4	R10	483	560	483	400	361	300
585A-4	R10	573	730	573	450	414	350
650A-4	R10	623	730	623	500	477	400
725A-4	R11	705	850	705	600	566	450
820A-4	R11	807	1020	807	700	625	500
880A-4	R11	807	1020	807	700	625	500

3AXD00000586715

U_N	Nominal voltage of the drive
I_1	Nominal input current (rms) at 40 °C (104 °F)
I_{max}	Maximum output current. Available for 2 seconds at start, otherwise as long as allowed by drive temperature.
I_2	Continuous rms output current. No overload capability at 40 °C (104 °F)
P_N	Typical motor power in no-overload use.
I_{Ld}	Continuous rms output current allowing 10% overload for 1 minute every 10 minutes
P_{Ld}	Typical motor power for light-overload use.
I_{Hd}	Continuous rms output current allowing 50% overload for 1 minute every 10 minutes
*	Continuous rms output current allowing 40% overload for 1 minute every 10 minutes
P_{Hd}	Typical motor power for heavy-duty use.

Note: To achieve the rated motor power given in the table, the rated current of the drive must be higher than or equal to the rated motor current. The power ratings apply to most IEC 34 motors at the nominal voltage of the drive.

We recommend to select the drive, motor and gear combination for the required motion profile with the DriveSize dimensioning tool available from ABB.

Output derating

NEMA and NEC RATINGS								
NEMA drive type ACH580-04-	NEC drive type ACH580-04-	Frame size	Input current	Output ratings				
				Nominal use	Light-duty use		Heavy-duty use	
				I_1	I_{max}	I_{Ld}	P_{Ld}	I_{Hd}
A								
A								
hp								
A								
hp								
$U_N = 440...480$ V (440, 460, 480 V)								
505A-4	483A-4	R10	483	560	483	400	361	300
585A-4	573A-4	R10	573	730	573	450	414	350
650A-4	623A-4	R10	623	730	623	500	477	400
725A-4	705A-4	R11	705	850	705	600	566	450
820A-4	807A-4	R11	807	1020	807	700	625	500
880A-4		R11	807	1020	807	700	625	500

3AXD00000586715

Derate the continuous output current of the drive if

- ambient temperature exceeds +40 °C (+104 °F) or
- drive is installed higher than 1000 m (3280 ft) above sea level
- switching frequency is other than default.

Note: The final derating factor is a multiplication of all applicable derating factors.

Ambient temperature derating

In the temperature range +40...55 °C (+104...131 °F), the rated output current is derated by 1% for every added 1 °C (1.8 °F) as follows. Calculate the output current by multiplying the current given in the rating table by the derating factor.

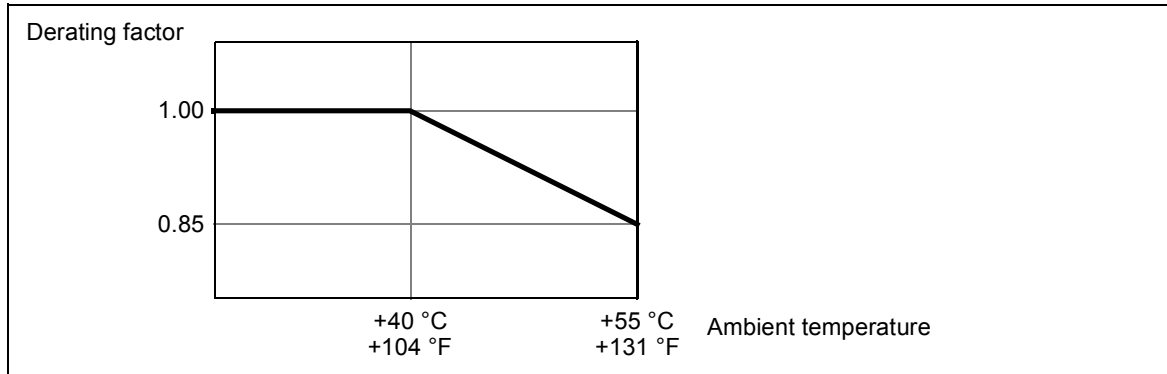

Altitude derating

At altitudes from 1000 to 4000 m (3300 to 13123 ft) above sea level, the derating is 1% for every 100 m (328 ft). For a more accurate derating, use the DriveSize PC tool.

Deratings for special settings in the drive control program

Switching frequencies other than 1.5 kHz can require output current derating. If you change the minimum switching frequency with parameter **97.02 Minimum switching frequency**, calculate the derated output current by multiplying the current given in the rating table by the derating factor given in the table below.

Frame size	Derating factor (k) for the minimum switching frequencies			
	1 kHz	2 kHz	4kHz	8 kHz
R10	1	0.92	0.78	0.58
R11	1	0.92	0.78	0.58

Note: Changing the value of parameter **97.01 Switching frequency reference** does not require derating.

For more information, contact local ABB.

Fuses (IEC)

aR fuses for protection against short-circuit in the input power cable or drive are listed below.

Ultrarapid (aR) fuses							
Drive type ACH580-04-	Input current (A)	Fuse					
		A	A ² s	V	Manufacturer	Type DIN 43620 	Size
$U_N = 380...415$ V (380, 400, 415 V)							
505A-4	505	800	490000	690	Bussmann	170M6812D	DIN3
585A-4	585	1000	985000	690	Bussmann	170M6814D	DIN3
650A-4	650	1000	985000	690	Bussmann	170M6814D	DIN3
725A-4	725	1250	2150000	690	Bussmann	170M8554D	DIN3
820A-4	820	1600	4150000	690	Bussmann	170M8557D	DIN3
880A-4	880	1600	4150000	690	Bussmann	170M8557D	DIN3
$U_N = 440...480$ V (440, 460, 480 V)							
505A-4	505	800	490000	690	Bussmann	170M6812D	DIN3
585A-4	585	1000	985000	690	Bussmann	170M6814D	DIN3
650A-4	650	1000	985000	690	Bussmann	170M6814D	DIN3
725A-4	725	1250	2150000	690	Bussmann	170M8554D	DIN3
820A-4	820	1600	4150000	690	Bussmann	170M8557D	DIN3
880A-4	880	1600	4150000	690	Bussmann	170M8557D	DIN3

3AXD0000586715

Note 1: See also [Implementing thermal overload and short-circuit protection](#) on page 61.

Note 2: In multicable installations, install only one fuse per phase (not one fuse per conductor).

Note 3: Fuses with higher current rating than the recommended ones must not be used. Fuses with lower current rating can be used.

Note 4: Fuses from other manufacturers can be used if they meet the ratings and the melting curve of the fuse does not exceed the melting curve of the fuse mentioned in the table.

Fuses (UL)

UL fuses for branch circuit protection per NEC are listed below. **Check that the operating time of the fuse is below 0.1 seconds.** The operating time depends on the fuse type, supply network impedance and the cross-sectional area, material and length of the supply cable. The fuses must be of the “non-time delay” type. Obey local regulations.

Drive type ACH580-04-	Input current (A)	Fuse				
		A	V	Manufacturer	UL class	Type
$U_N = 400$ V						
505A-4	505	600	600	Bussmann	T	JJS-600
585A-4	585	800	600	Ferraz	L	A4BY800
650A-4	650	800	600	Ferraz	L	A4BY800
725A-4	725	800	600	Ferraz	L	A4BY800
820A-4	820	900	600	Ferraz	L	A4BY900
880A-4	880	1000	600	Ferraz	L	A4BY1000

Note 1: See also [Implementing thermal overload and short-circuit protection](#) on page 61.

Note 2: In multicable installations, install only one fuse per phase (not one fuse per conductor).

Note 3: Fuses with higher current rating than the recommended ones must not be used. Fuses with lower current rating can be used.

Note 4: Fuses from other manufacturers can be used if they meet the ratings and the melting curve of the fuse does not exceed the melting curve of the fuse mentioned in the table.

Dimensions, weights and free space requirements

Standard drive module configuration (IP00) and option +B051 (IP20 shrouds)								
Frame size	Height		Width		Depth		Weight*	
	mm	in	mm	in	mm	in	kg	lb
R10	1462	57.55	350	13.78	529	20.81	161	355
R11	1662	65.43	350	13.78	529	20.81	199	439

Weight of optional selections										
Frame size	+0H354		+E208		+H356		+0H371		+H370	
	kg	lb	kg	lb	kg	lb	kg	lb	kg	lb
R10	-7	-15	3	7	2	4	-2.9	-6	2.9	6
R11	-7	-15	3	7	2	4	-2.9	-6	2.9	6

Height of drive module without pedestal (option +H354)		
Frame size	mm	in
R10/R11	-100	-3.94

For requirements of free space around the drive module, see page [49](#).

Losses, cooling data and noise

Drive type	Frame size	Air flow		Heat dissipation W	Noise dB(A)
		m ³ /h	ft ³ /min		
ACH580-505A-4	R10	1200	707	5602	72
ACH580-585A-4	R10	1200	707	6409	72
ACH580-650A-4	R10	1200	707	8122	72
ACH580-725A-4	R11	1200	707	8764	72
ACH580-820A-4	R11	1200	707	9862	72
ACH580-880A-4	R11	1420	848	10578	71

3AXD00000586715

Terminal and lead-through data for the power cables

The maximum accepted cable size is $4 \times (3 \times 240) \text{ mm}^2$ or $4 \times (3 \times 500 \text{ AWG})$. Screw size for connecting busbars to the drive module input and output busbars: M12, tightening torque 50...75 N·m.

- **Drive modules without output cable connection terminals (+0H371) and with a common mode filter (+E208)**

It is possible to use the maximum cable size ($4 \times [3 \times 240] \text{ mm}^2$ or $4 \times [(3 \times 500 \text{ AWG})]$) only with special cable lugs and additional insulation. For more information, contact your local ABB representative.

Terminal data for the control cables

See page [84](#).

Electrical power network specification

Voltage (U_1)	ACS580-04-xxxx-4 drive modules: 380...480 V AC 3-phase $\pm 10\%$. This is indicated in the type designation label as typical input voltage levels 3 ~ 400/480 V AC.
Network type	TN (grounded) and IT (ungrounded) systems
Rated conditional short-circuit current I_{CC} (IEC 61800-5-1)	Maximum allowable prospective short-circuit current is 65 kA when protected by the fuses given in the fuse table.
Short-circuit current protection (UL 508A)	The drive is suitable for use on a circuit capable of delivering not more than 100,000 rms symmetrical amperes at 600 V maximum when by the fuses given in the fuse table.
Frequency	48 to 63 Hz, maximum rate of change 17%/s
Imbalance	Max. $\pm 3\%$ of nominal phase to phase input voltage
Fundamental power factor (cos ϕ_1)	0.98 (at nominal load)

Motor connection data

Motor types	Asynchronous AC induction motors, synchronous reluctance motors and synchronous permanent magnet motors	
Voltage (U_2)	0 to U_1 , 3-phase symmetrical. This is indicated in the type designation label as typical output voltage level 3 ~ 0... U_1 ,	
Frequency	0...500 Hz	
Frequency resolution	0.01 Hz	
Current	See section Ratings .	
Frequency	0...500 Hz. <u>For drives with du/dt filter:</u> 200 Hz	
Switching frequency	= nominal switching frequency. Minimum switching frequency 1.5 kHz, 2 kHz, 4 kHz, 8 kHz (depends on the parameter settings)	
Maximum recommended motor cable length	Vector control	Scalar control
	300 m (984 ft)	300 m (984 ft)
Note: Motor cable longer than 100 m (328 ft) is allowed but then the EMC Directive requirements of Category C3 may not be fulfilled.		

DC connection data

Drive type	I_{DC} (A)	Capacitance (mF)
$U_N = 400$ V		
ACH580-04-505A-4	640	14
ACH580-04-585A-4	714	14
ACH580-04-650A-4	870	14
ACH580-04-725A-4	909	21
ACH580-04-820A-4	1033	21
ACH580-04-880A-4	1120	21



Control unit (CCU-24) connection data

External power supply Term. 40, 41	Maximum power: 36 W, 1.50 A at 24 V AC/DC $\pm 10\%$ as standard Terminal size: 0.14...2.5 mm ²
+24 V DC output (Term. 10)	Total load capacity of this output is 6.0 W (250 mA / 24 V) minus the power taken by the option modules installed on the board. Terminal size: 0.14...2.5 mm ²

Digital inputs DI1...DI6 (Term. 13...18)	Input type: NPN/PNP Terminal size: 0.14...2.5 mm ² <u>DI1...DI5 (Term.13...17)</u> 12/24 V DC logic levels: "0" < 4 V, "1" > 8 V R_{in} : 3 kohm Hardware filtering: 0.04 ms, digital filtering: 2 ms sampling <u>DI5 (Term.17)</u> Can be used as a digital or frequency input. 12/24 V DC logic levels: "0" < 3 V, "1" > 8 V R_{in} : 3 kohm Max. frequency 16 kHz Symmetrical signal (duty cycle D = 0.50) <u>DI6 (Term.18)</u> Can be used as a digital or PTC input. Digital input mode. 12/24 V DC logic levels: "0" < 4 V, "1" > 8 V R_{in} : 3 kohm Hardware filtering: 0.04 ms, digital filtering: 2 ms sampling Note: DI6 is not supported in the NPN configuration. PTC mode – PTC thermistor can be connected between DI6 and +24VDC: < 1.5 kohm = '1' (low temperature), > 4 kohm = '0' (high temperature), open circuit = '0' (high temperature). DI6 is not a reinforced/double insulated input. Connecting the motor PTC sensor to this input requires usage of a reinforced/double insulated PTC sensor inside the motor.
Relay outputs RO1...RO3 (Term. 19...27)	250 V AC / 30 V DC, 2 A Terminal size: 0.14...2.5 mm ² See section Isolation areas on page 122.
Analog inputs AI1 and AI2 (Term. 2 and 5)	Current/voltage input mode selected with a parameter Current input: 0(4)...20 mA, R_{in} : 100 ohm Voltage input: 0(2)...10 V, R_{in} : > 200 kohm Terminal size: 0.14...2.5 mm ² Inaccuracy: typical $\pm 1\%$, max. $\pm 1.5\%$ of full scale
Analog outputs AO1 and AO2 (Term. 7 and 8)	Current/voltage output mode for AO1 selected with a parameter Current output: 0...20 mA, R_{load} : < 500 ohm Voltage output: 0...10 V, R_{load} : > 100 kohm (AO1 only) Terminal size: 0.14...2.5 mm ² Inaccuracy: $\pm 1\%$ of full scale (in voltage and current modes)
Reference voltage output for analog inputs +10V DC (Term. 4)	Max. 20 mA output Inaccuracy: $\pm 1\%$
Safe torque off (STO) inputs IN1 and IN2 (Term. 37 and 38) STO cable	24 V DC logic levels: "0" < 5 V, "1" > 13 V R_{in} : 2.47 kohm Terminal size: 0.14...2.5 mm ² Maximum cable length 300 m (984 ft) between activation switch (K) and drive control board, see section Wiring examples on page 143 and Safety data on page 150.
Control panel - drive connection	EIA-485, male RJ-45 connector, max. cable length 100 m
Control panel - PC connection	USB Type Mini-B, max. cable length 2 m

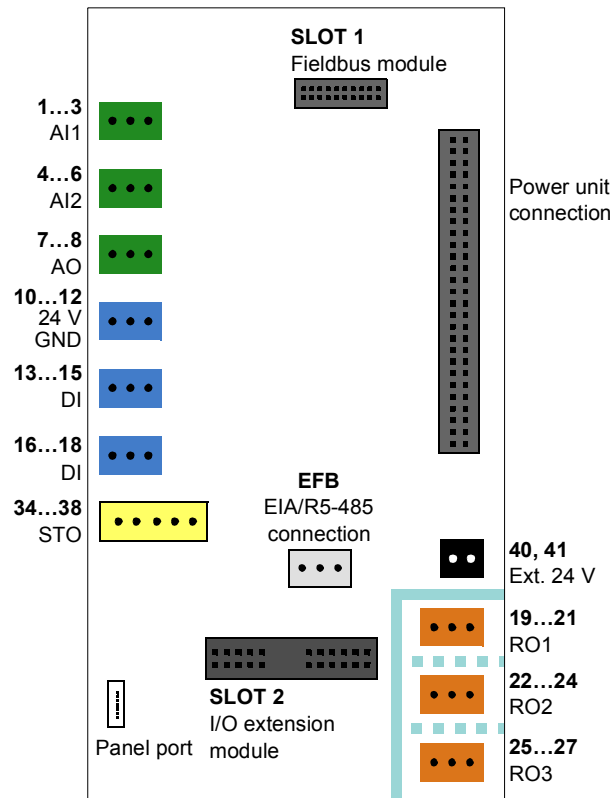
Isolation areas



-  Reinforced insulation (IEC/EN 61800-5-1:2016)
-  Functional insulation (IEC/EN 61800-5-1:2016)

The terminals on the control board fulfill the Protective Extra Low Voltage (PELV) requirements (EN 50178): There is reinforced insulation between the user terminals which only accept ELV voltages and terminals that accept higher voltages (relay outputs).

Note: There is functional insulation also between the individual relay outputs.

Note: There is reinforced insulation on the power unit.

Control panel type

- +J400 ACH-AP-H Hand-Off-Auto control panel (standard)
- +J424 CDUM-01 Blank control panel cover
- +J429 ACS-AP-W Assistant control panel with bluetooth interface

Efficiency

Approximately 98% at nominal power level

Degree of protection

IP00. With option +B051: IP20

Ambient conditions

Environmental limits for the drive are given below. The drive is to be used in a heated, indoor, controlled environment.

	Operation installed for stationary use	Storage in the protective package	Transportation in the protective package
Installation site altitude	For TN and TT <u>neutral-grounded network systems and IT non-corner grounded network systems</u> : 0 to 4000 m (13123 ft) above sea level For TN, TT and IT <u>corner-grounded network systems</u> : 0 to 2000 m (6561 ft) above sea level Above 1000 m [3281 ft]), see page 117.	-	-
Air temperature	-15 to +55 °C (5 to 131 °F). No frost allowed. See page 117.	-40 to +70 °C (-40 to +158 °F)	-40 to +70 °C (-40 to +158 °F)
Relative humidity	5 to 95%	Max. 95%	Max. 95%
	No condensation allowed. Maximum allowed relative humidity is 60% in the presence of corrosive gases.		
Contamination levels (IEC 60721-3-3, IEC 60721-3-2, IEC 60721-3-1)	No conductive dust allowed.		
	Chemical gases: Class 3C2 Solid particles: Class 3S2	Chemical gases: Class 1C2 Solid particles: Class 1S3	Chemical gases: Class 2C2 Solid particles: Class 2S2
Atmospheric pressure	70 to 106 kPa 0.7 to 1.05 atmospheres	70 to 106 kPa 0.7 to 1.05 atmospheres	60 to 106 kPa 0.6 to 1.05 atmospheres
Vibration (IEC 60068-2-6. Test Fc)	Max. 0.1 mm (0.004 in.) (10 to 57 Hz), max. 10 m/s ² (33 ft/s ²) (57 to 150 Hz) sinusoidal	Max. 1 mm (0.04 in.) (5 to 13.2 Hz), max. 7 m/s ² (23 ft/s ²) (13.2 to 100 Hz) sinusoidal	Max. 3.5 mm (0.14 in.) (2 to 9 Hz), max. 15 m/s ² (49 ft/s ²) (9 to 200 Hz) sinusoidal
Shock (IEC 60068-2-27)	Not allowed	Max. 100 m/s ² (330 ft./s ²), 11 ms	Max. 100 m/s ² (330 ft./s ²), 11 ms
Free fall	Not allowed	100 mm (4 in.) for weight over 100 kg (220 lb)	100 mm (4 in.) for weight over 100 kg (220 lb)

Materials

Drive enclosure

- PC/ABS 2.5 mm, color NCS 1502-Y (RAL 9002 / PMS 420 C)
- hot-dip zinc coated steel sheet 1.5 to 2.5 mm, thickness of coating 100 micrometers, color NCS 1502-Y

Package

Plywood and cardboard, bands PP.

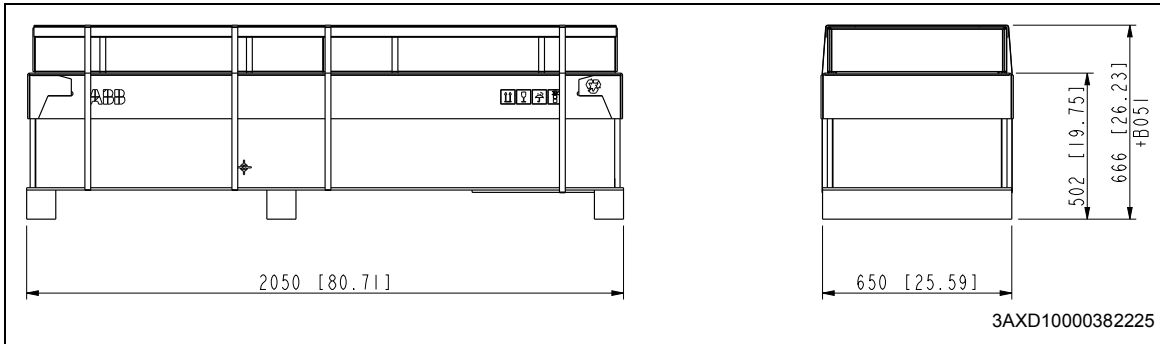

Disposal

The main parts of the drive can be recycled to preserve natural resources and energy. Product parts and materials should be dismantled and separated.

Generally all metals, such as steel, aluminum, copper and its alloys, and precious metals can be recycled as material. Plastics, rubber, cardboard and other packaging material can be used in energy recovery. Printed circuit boards and DC capacitors (C1-1 to C1-x) need selective treatment according to IEC 62635 guidelines. To aid recycling, plastic parts are marked with an appropriate identification code.

Contact your local ABB distributor for further information on environmental aspects and recycling instructions for professional recyclers. End of life treatment must follow international and local regulations.

Applicable standards

Standard	Description
EN 61800-5-1:2016	The drive complies with the following standards. <i>Adjustable speed electrical power drive systems. Part 5-1: Safety requirements – electrical, thermal and energy</i>
EN 60204-1:2006 + A1:2010	<i>Safety of machinery. Electrical equipment of machines. Part 1: General requirements.</i> Provisions for compliance: The final assembler of the machine is responsible for installing - emergency-stop device - supply disconnecting device - IP00 drive module into a cabinet.
IEC/EN 60529:1991 + A2:2013	<i>Degrees of protection provided by enclosures (IP code)</i>
EN 61800-3:2004 +A1:2012	<i>Adjustable speed electrical power drive systems. Part 3: EMC requirements and specific test methods</i>
UL 508C 3rd edition	<i>UL Standard for Safety, Power Conversion Equipment, second edition</i>

CE marking

A CE mark is attached to the drive to verify that the unit follows the provisions of the European Low Voltage, EMC, and RoHS Directives. The CE marking also verifies that the drive, in regard to its safety functions (such as Safe torque off), conforms with the Machinery Directive as a safety component.

■ Compliance with the European Low Voltage Directive

The compliance with the European Low Voltage Directive has been verified according to standards EN 60204-1 and EN 61800-5-1.

■ Compliance with the European EMC Directive

The EMC Directive defines the requirements for immunity and emissions of electrical equipment used within the European Union. The EMC product standard (EN 61800-3:2004) covers requirements stated for drives. See section [Compliance with EN 61800-3:2004](#) below.

■ Compliance with the European RoHS Directive

The RoHS Directive defines the restriction of the use of certain hazardous substances in electrical and electronic equipment.

Compliance with the European Machinery Directive

The drive is an electronic product which is covered by the European Low Voltage Directive. However, the drive includes the Safe torque off function and can be equipped with other safety functions for machinery which, as safety components, are in the scope of the Machinery Directive. These functions of the drive comply with European harmonized standards such as EN 61800-5-2.

Compliance with EN 61800-3:2004

■ Definitions

EMC stands for **E**lectromagnetic **C**ompatibility. It is the ability of electrical/electronic equipment to operate without problems within an electromagnetic environment. Likewise, the equipment must not disturb or interfere with any other product or system within its locality.

First environment includes establishments connected to a low-voltage network which supplies buildings used for domestic purposes.

Second environment includes establishments connected to a network not supplying domestic premises.

Drive of category C2: drive of rated voltage less than 1000 V and intended to be installed and started up only by a professional when used in the first environment.

Note: A professional is a person or organization having necessary skills in installing and/or starting up power drive systems, including their EMC aspects.

Drive of category C3: drive of rated voltage less than 1000 V and intended for use in the second environment and not intended for use in the first environment.

Drive of category C4: drive of rated voltage equal to or above 1000 V, or rated current equal to or above 400 A, or intended for use in complex systems in the second environment.

Category C3

The drive complies with the standard with the following provisions:

1. The drive is equipped with EMC filter (option +E210) and common mode filter (option+E208).
2. The motor and control cables are selected as specified in the hardware manual.
3. The drive is installed according to the instructions given in the hardware manual.
4. Maximum motor cable length is 100 meters.
5. The value of parameter 97.01 Switching frequency reference must be set to 2 kHz.



WARNING! A drive of category C3 is not intended to be used on a low-voltage public network which supplies domestic premises. Radio frequency interference is expected if the drive is used on such a network.

Category C4

If the provisions under *Category C3* cannot be met, the requirements of the standard can be met as follows:

1. It is ensured that no excessive emission is propagated to neighboring low-voltage networks. In some cases, the inherent suppression in transformers and cables is sufficient. If in doubt, the supply transformer with static screening between the primary and secondary windings can be used.

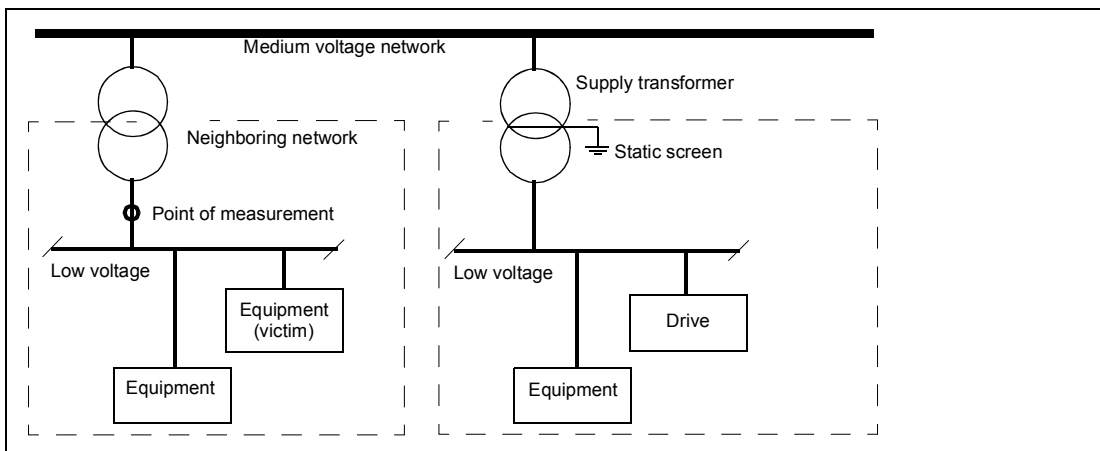

2. An EMC plan for preventing disturbances is drawn up for the installation. A template is available from the local ABB representative.
3. The motor and control cables are selected as specified in the hardware manual.
4. The drive is installed according to the instructions given in the hardware manual.



WARNING! A drive of category C4 is not intended to be used on a low-voltage public network which supplies domestic premises. Radio frequency interference is expected if the drive is used on such a network.

UL marking

The drive modules are cULus Listed.

- Make sure that the drive type designation label includes the cULus Listed marking.
- **CAUTION - Risk of electric shock.** After disconnecting the input power, always wait for 5 minutes to let the intermediate circuit capacitors discharge before you start working on the drive, motor or motor cable.
- The drive must be installed in clean air according to the enclosure classification. Cooling air must be clean, free from corrosive materials and electrically conductive dust. (IP55)- UL Type 12 enclosure. This enclosure provides protection from airborne dust and light sprays or splashing water from all directions.
- The maximum surrounding air temperature is 40 °C (104 °F) at rated current. The current is derated for 40 to 55 °C (104 to 131 °F).
- The drive is suitable for use in a circuit capable of delivering not more than 100,000 rms symmetrical amperes, 600 V maximum when protected by the UL fuses given in the table on page 118. The ampere rating is based on tests done according to the appropriate UL standard.
- The cables located within the motor circuit must be rated for at least 75 °C (167 °F) in UL-compliant installations.
- Integral solid state short circuit protection does not provide branch circuit protection. The input cable must be protected with fuses. Suitable IEC fuses are listed on page 118 and UL classified fuses on page 118. These fuses provide branch circuit protection in accordance with the National Electrical Code (NEC) and Canadian Electrical Code. For installation in the United States, also obey any other applicable local codes. For installation in Canada, also obey any applicable provincial codes.

Note: Circuit breakers must not be used without fuses in the USA. Contact your local representative for suitable circuit breakers.
- The drive provides motor overload protection. For the adjustments, see the firmware manual.
- For drive overvoltage category, see page 122. For pollution degree, see page 123.

China RoHS marking

The *People's Republic of China Electronic Industry Standard* (SJ/T 11364-2014) specifies the marking requirements for hazardous substances in electronic and electrical products. The green mark is attached to the drive to verify that it does not contain toxic and hazardous substances or elements above the maximum concentration values, and that it is an environmentally-friendly product which can be recycled and reused.

RCM marking

RCM marking is required in Australia and New Zealand. An RCM mark is attached to the drive modules to verify compliance with the relevant standard (IEC 61800-3:2004), mandated by the Trans-Tasman Electromagnetic Compatibility Scheme.

For fulfilling the requirements of the standard, see section *Compliance with EN 61800-3:2004* on page 125.



WEEE marking

The drive is marked with the wheeled bin symbol. It indicates that at the end of life the drive should enter the recycling system at an appropriate collection point and not placed in the normal waste stream. See section *Disposal* on page [124](#).

EAC (Eurasian Conformity) marking

The drive has EAC certification. EAC marking is required in Russia, Belarus and Kazakhstan.

Cybersecurity disclaimer

This product is designed to be connected to and to communicate information and data via a network interface. It is Customer's sole responsibility to provide and continuously ensure a secure connection between the product and Customer network or any other network (as the case may be). Customer shall establish and maintain any appropriate measures (such as but not limited to the installation of firewalls, application of authentication measures, encryption of data, installation of anti-virus programs, etc) to protect the product, the network, its system and the interface against any kind of security breaches, unauthorized access, interference, intrusion, leakage and/or theft of data or information. ABB and its affiliates are not liable for damages and/or losses related to such security breaches, any unauthorized access, interference, intrusion, leakage and/or theft of data or information.

Disclaimer

The manufacturer shall have no obligation with respect to any product which (i) has been improperly repaired or altered; (ii) has been subjected to misuse, negligence or accident; (iii) has been used in a manner contrary to the manufacturer's instructions; or (iv) has failed as a result of ordinary wear and tear.

13

Dimension drawings

Contents of this chapter

This chapter contains dimension drawings of the drive modules.

R10 standard configuration



3AXD5000017294

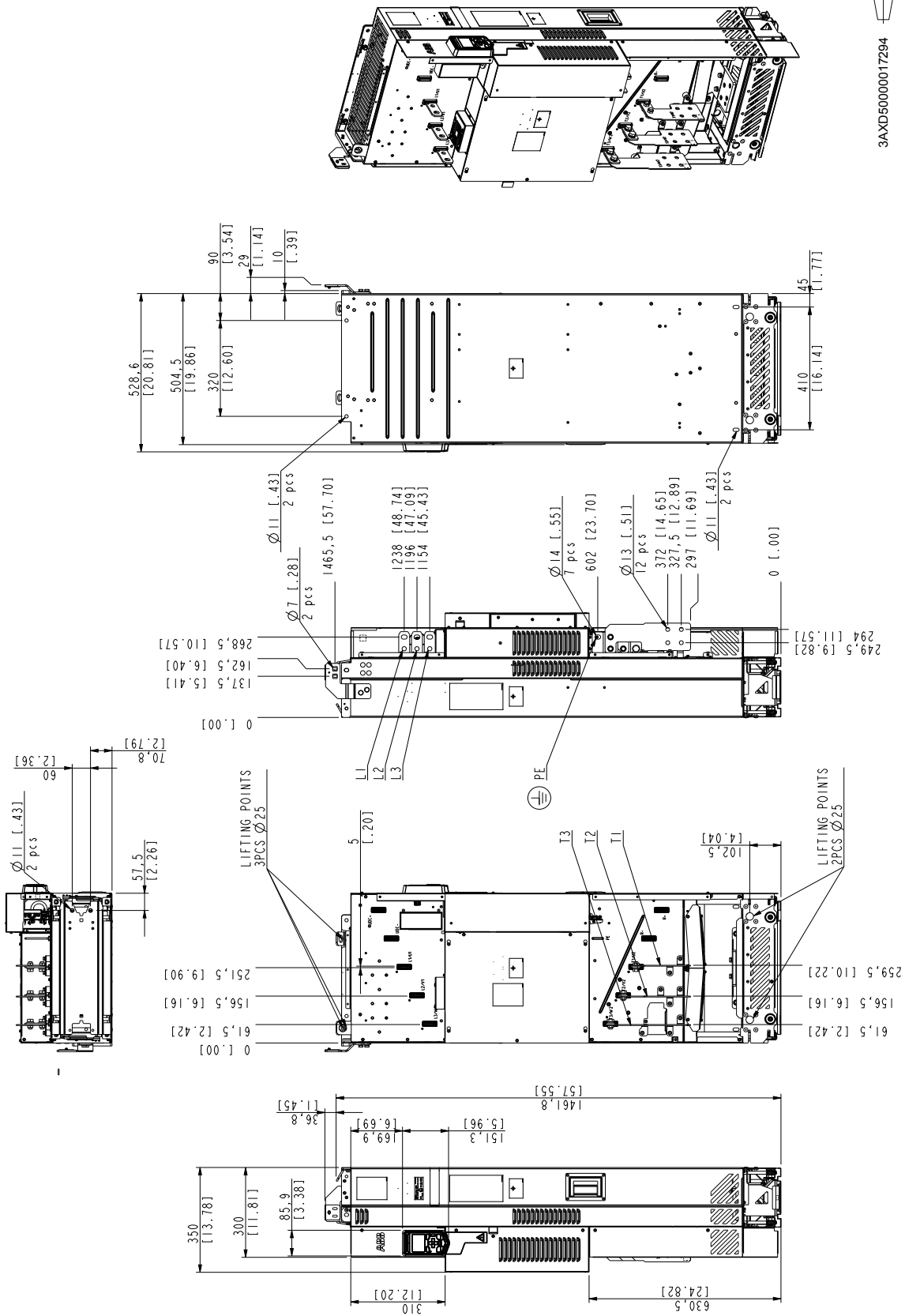

R10 with options +E208+0H354+H356+0H370+0H371

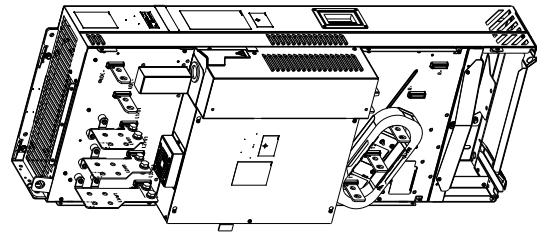
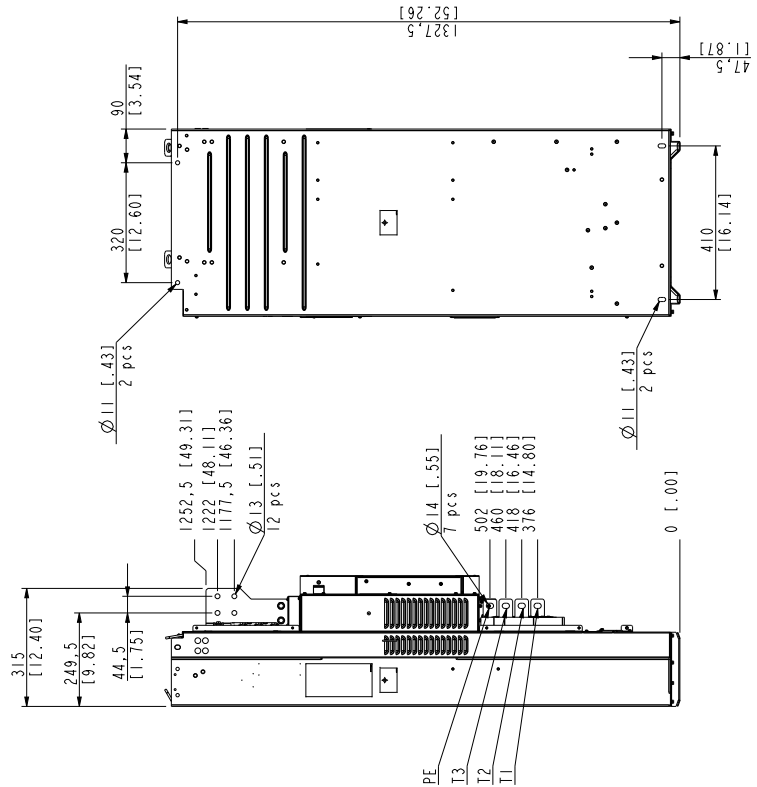
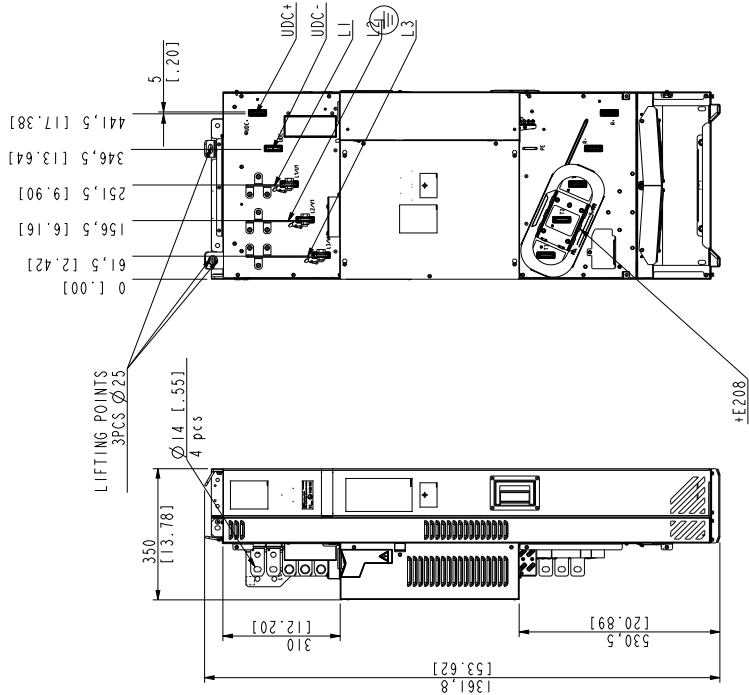
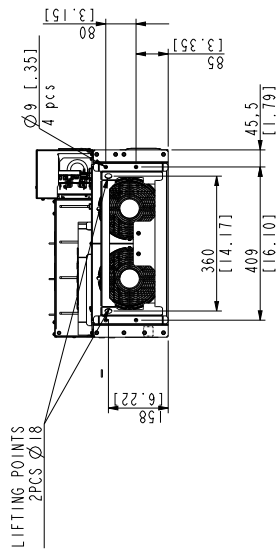

3AXD5000017294

R10 with option +B051

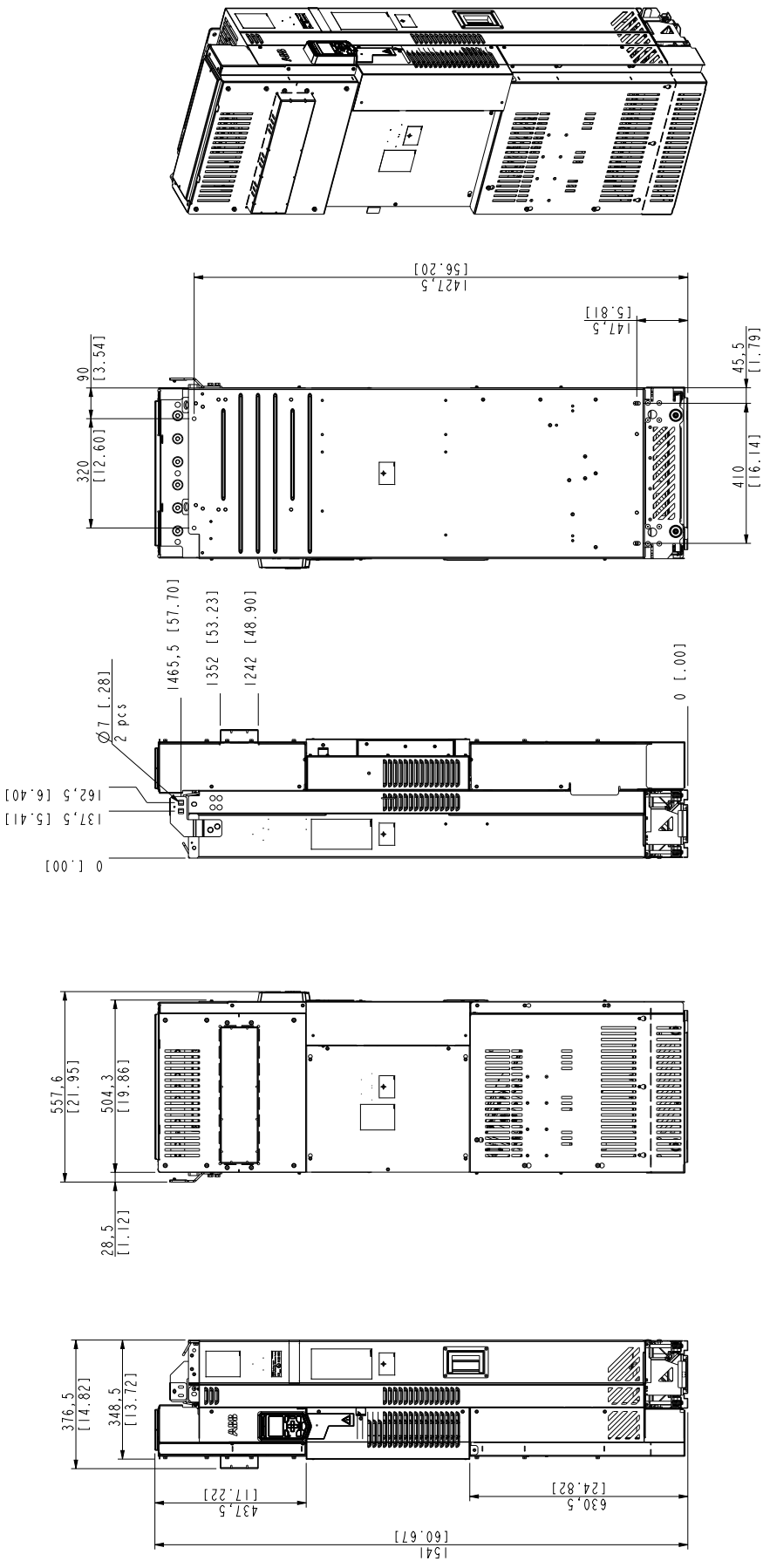

R11 standard configuration

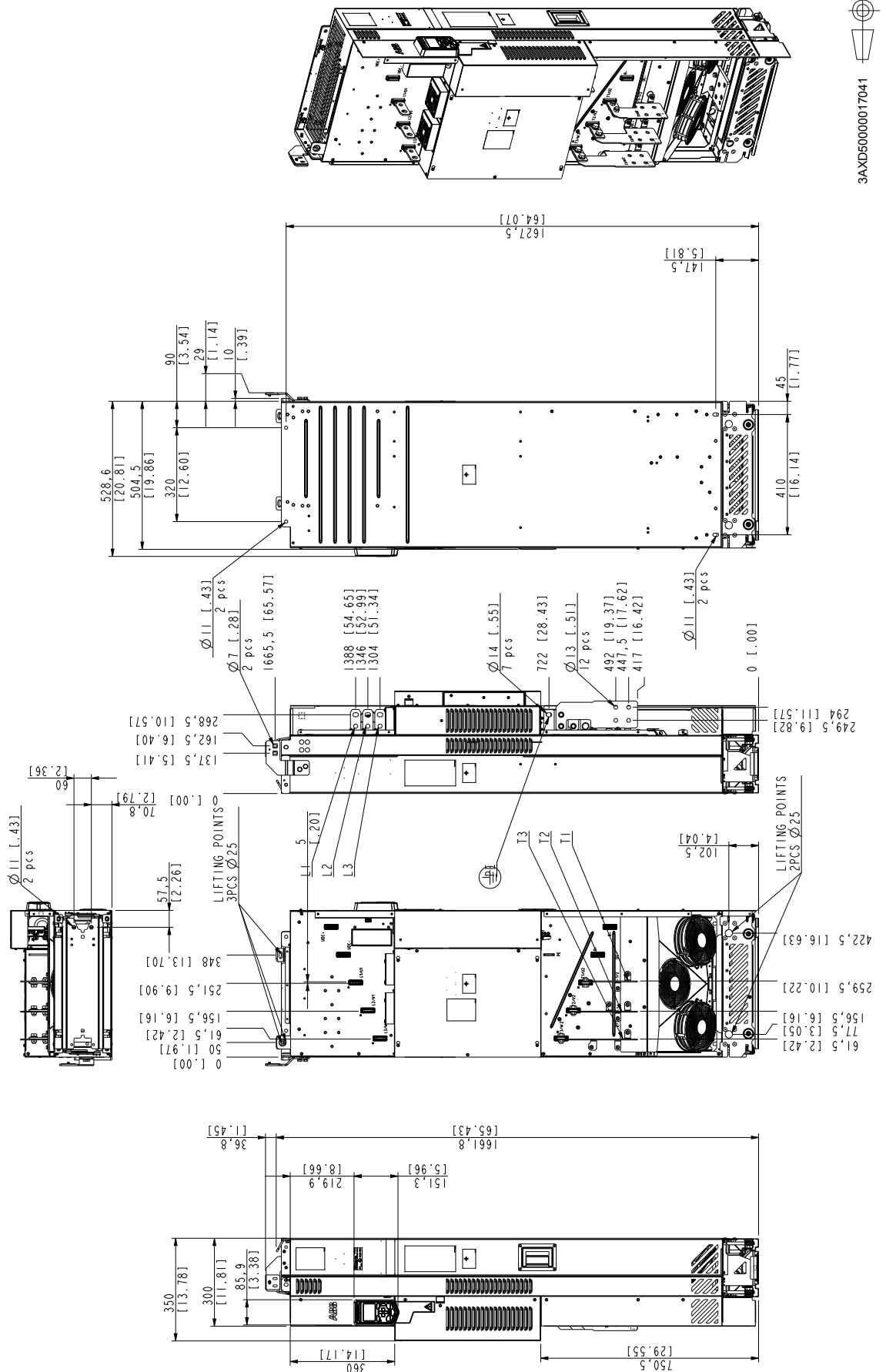

3AXD50000017041

R11 with options +E208+0H354+H356+0H370+0H371



3AXD50000017041

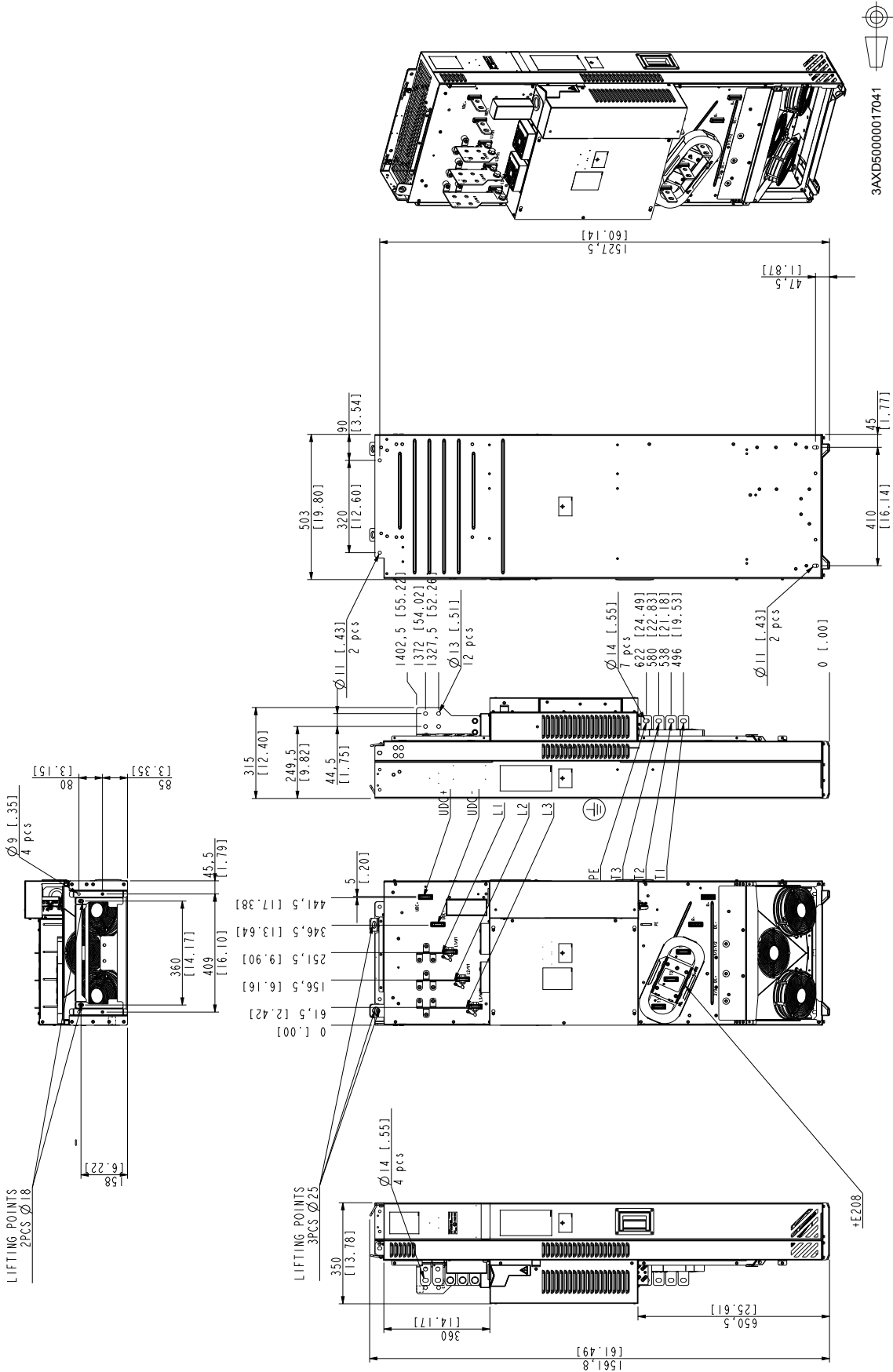

R11 with option +B051

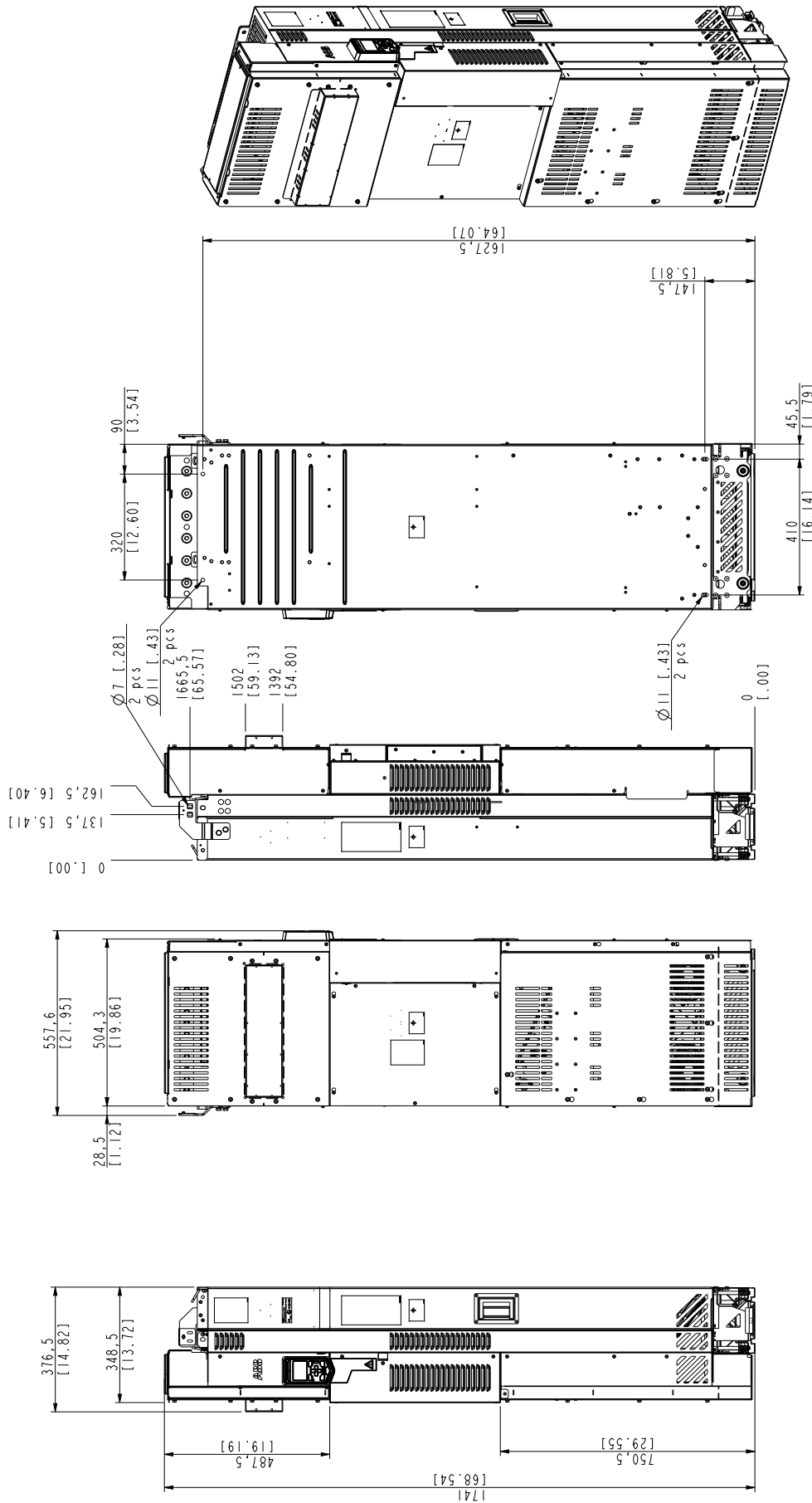

3AXD5000017041

Air baffles for the drive module with option +B051

This drawing shows the dimensions of the hole in the air baffle around the drive module with option +B051. The drawing also shows the correct vertical location area of the air baffle as measured from the top grill.

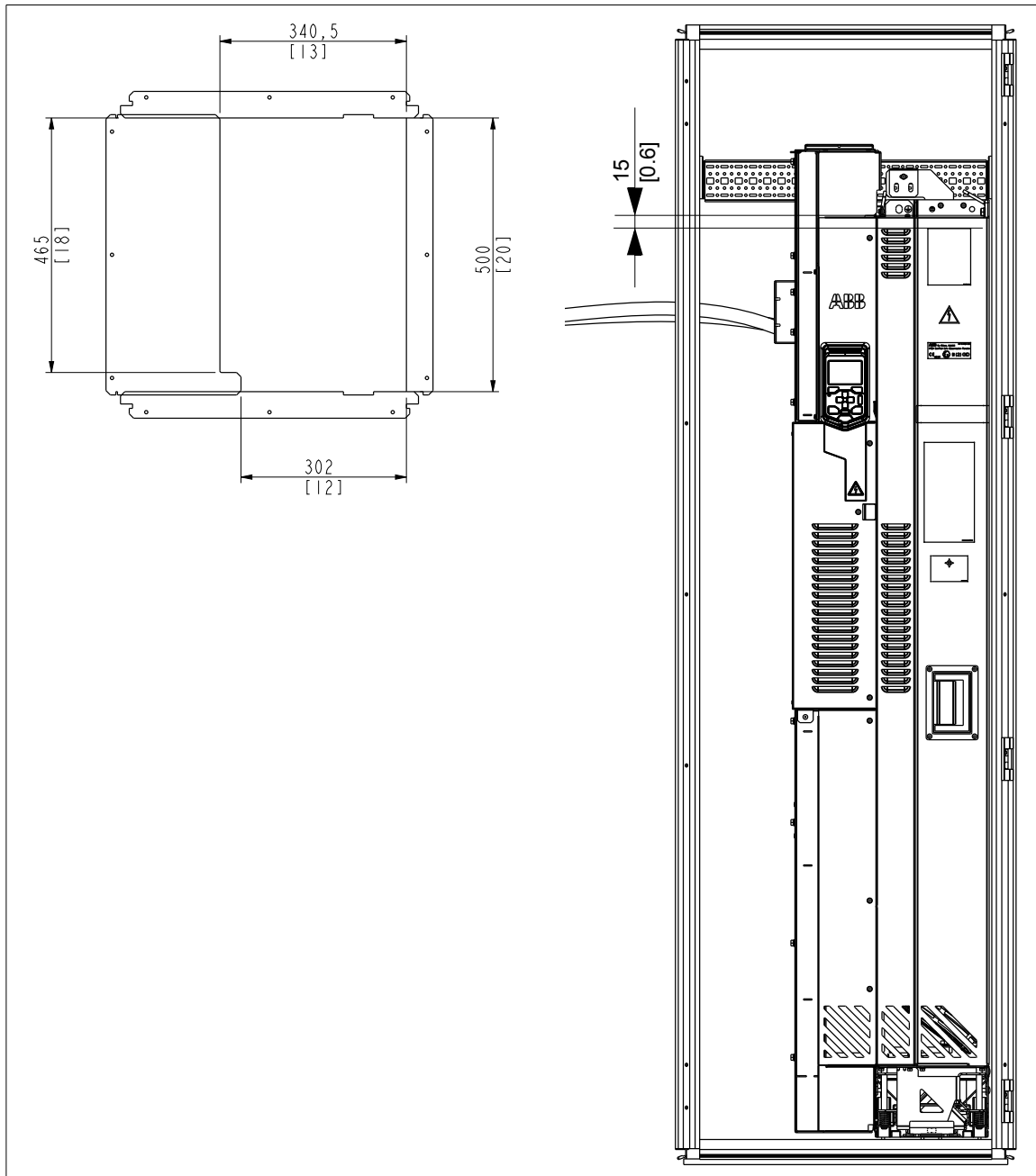

14

Example circuit diagram

Contents of this chapter

This chapter shows an example circuit diagram for a cabinet-installed drive module.

Example circuit diagram

This diagram is an example for the main wiring of a drive cabinet. Note that the diagram includes components which are not included in a basic delivery (* plus code options, ** other options, *** to be acquired by the customer).

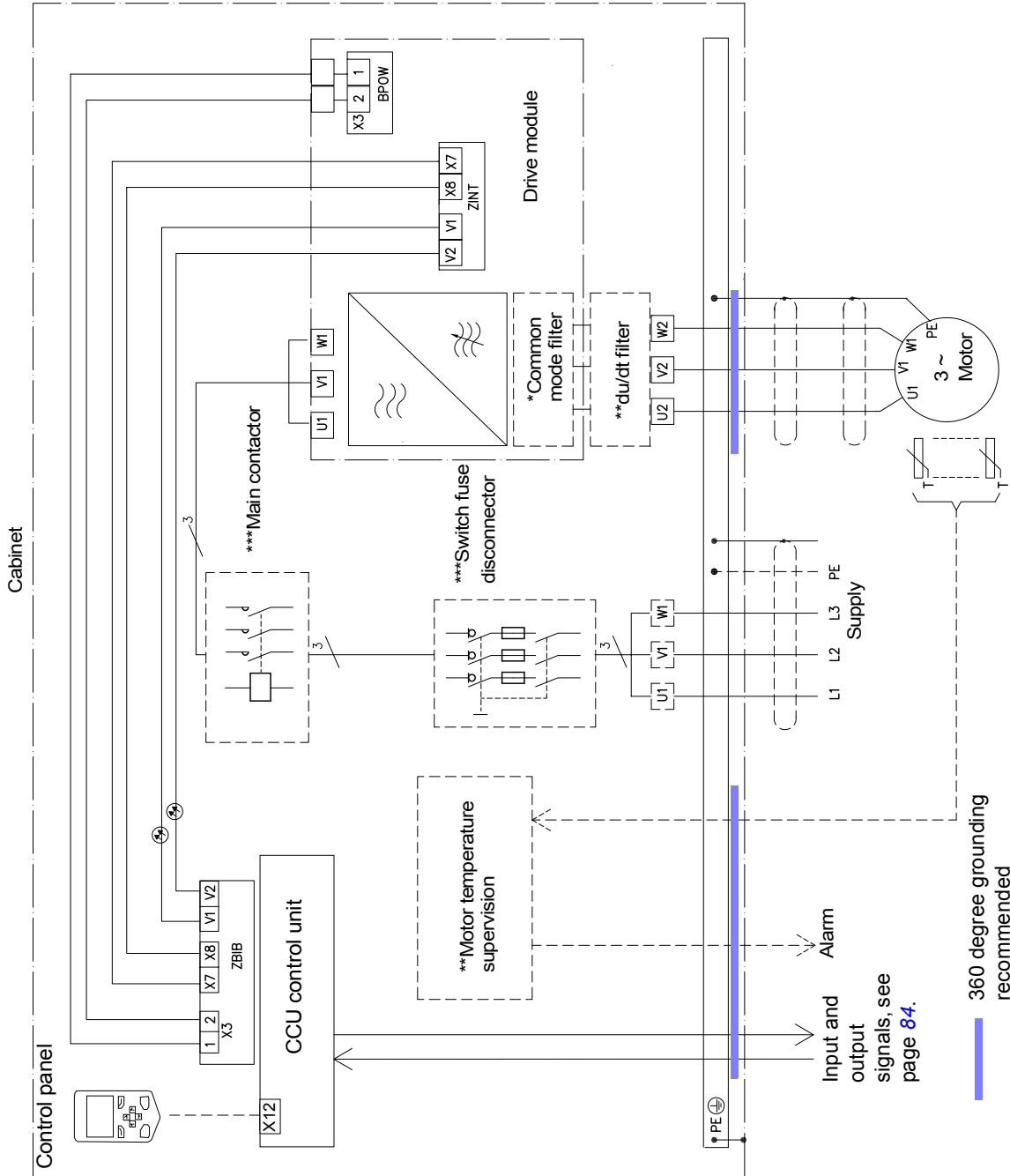

15

Safe torque off function

Contents of this chapter

This chapter describes the Safe torque off (STO) function of the drive and gives instructions for its use.

Description

The Safe torque off function can be used, for example, to construct safety or supervision circuits that stop the inverter in case of danger (such as an emergency stop circuit). Another possible application is a prevention of unexpected start-up switch that enables short-time maintenance operations like cleaning or work on non-electrical parts of the machinery without switching off the power supply to the inverter.

When activated, the Safe torque off function disables the control voltage of the power semiconductors of the drive output stage (A, see diagram below), thus preventing the drive from generating the torque required to rotate the motor. If the motor is running when Safe torque off is activated, it coasts to a stop.

The Safe torque off function has a redundant architecture, that is, both channels must be used in the safety function implementation. The safety data given in this manual is calculated for redundant use, and does not apply if both channels are not used.

The Safe torque off function of the drive complies with these standards:

Standard	Name
EN 60204-1:2006/AC:2010	<i>Safety of machinery – Electrical equipment of machines – Part 1: General requirements</i>
IEC 61326-3-1:2008	<i>Electrical equipment for measurement, control and laboratory use – EMC requirements – Part 3-1: Immunity requirements for safety-related systems and for equipment intended to perform safety-related functions (functional safety) – General industrial applications</i>

Standard	Name
IEC 61508-1:2010	<i>Functional safety of electrical/electronic/programmable electronic safety-related systems – Part 1: General requirements</i>
IEC 61508-2:2010	<i>Functional safety of electrical/electronic/programmable electronic safety-related systems – Part 2: Requirements for electrical/electronic/programmable electronic safety-related systems</i>
IEC 61511:2016	<i>Functional safety – Safety instrumented systems for the process industry sector</i>
EN 61800-5-2:2007 IEC 61800-5-2:2016	<i>Adjustable speed electrical power drive systems – Part 5-2: Safety requirements – Functional</i>
EN 62061:2005 + A1:2013 IEC 62061:2005 + A2:2015	<i>Safety of machinery – Functional safety of safety-related electrical, electronic and programmable electronic control systems</i>
EN ISO 13849-1:2015	<i>Safety of machinery – Safety-related parts of control systems – Part 1: General principles for design</i>
EN ISO 13849-2:2012	<i>Safety of machinery – Safety-related parts of control systems – Part 2: Validation</i>

The function also corresponds to Prevention of unexpected start-up as specified by EN 1037:1995 + A1:2008 and Uncontrolled stop (stop category 0) as specified in EN/IEC 60204-1.

■ Compliance with the European Machinery Directive

See section [Compliance with the European Machinery Directive](#) on page 125. See *Electrical planning instructions for ACS880 multidrive cabinets and modules* (3AUA0000102324 [English]).

Wiring

The following diagrams present examples of Safe torque off wiring for

- a single drive (page 141)
- multiple drives (page 145)
- multiple drives when an external 24 V DC power supply is used (page 146).

For information on the specifications of the STO input, see section [Default I/O connection diagram \(ABB standard macro\)](#) on page 84.

For drives with option [+L537](#), see *CPTC-02 ATEX-certified thermistor protection module, Ex II (2) GD (+L537+Q971) user's manual* (3AXD50000030058 [English]).

■ Activation switch

In the wiring diagrams below, the activation switch has the designation [K]. This represents a component such as a manually operated switch, an emergency stop push button switch, or the contacts of a safety relay or safety PLC.

- In case a manually operated activation switch is used, the switch must be of a type that can be locked out to the open position.
- The contacts of the switch or relay must open/close within 200 ms of each other.
- An CPTC-02 thermistor protection module can also be used. For more information, see section [CPTC-02 ATEX-certified thermistor protection module, \(external 24 V AC/DC and isolated PTC interface\)](#) on page 172.

■ Cable types and lengths

- Double-shielded twisted-pair cable is recommended.
- Maximum cable lengths:
 - 300 m (1000 ft) between activation switch [K] and drive control unit
 - 60 m (200 ft) between multiple drives
 - 60 m (200 ft) between external power supply and first drive.

Note: The voltage at the INx terminals of each control unit must be at least 17 V DC to be interpreted as “1”.

■ Grounding of protective shields

- Ground the shield in the cabling between the activation switch and the control unit at the control unit.
- Ground the shield in the cabling between two control units at one control unit only.

■ Single drive (internal power supply)

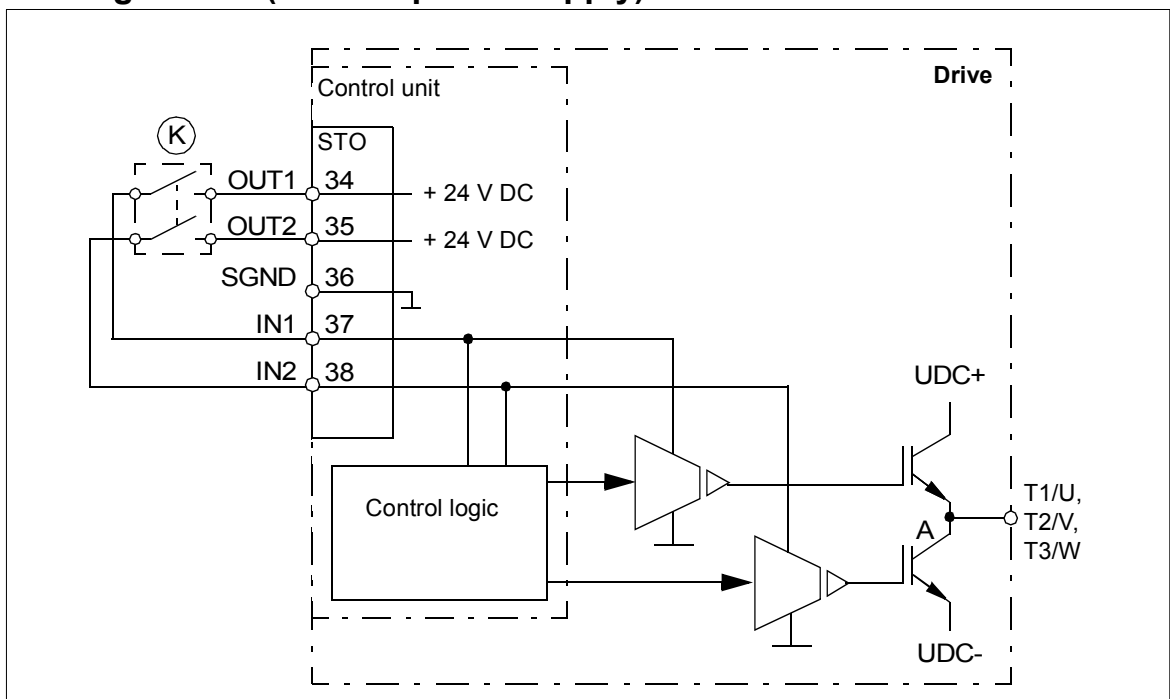

■ Single drive (external +24 V DC power supply)

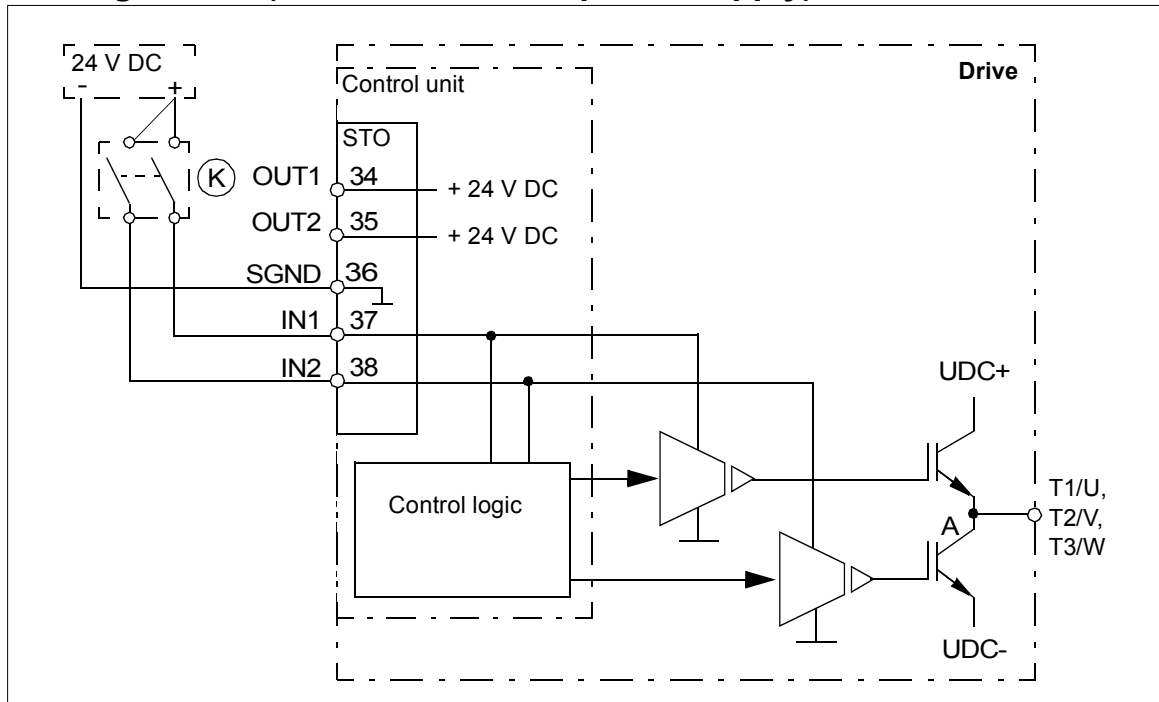

■ Dual-channel connection

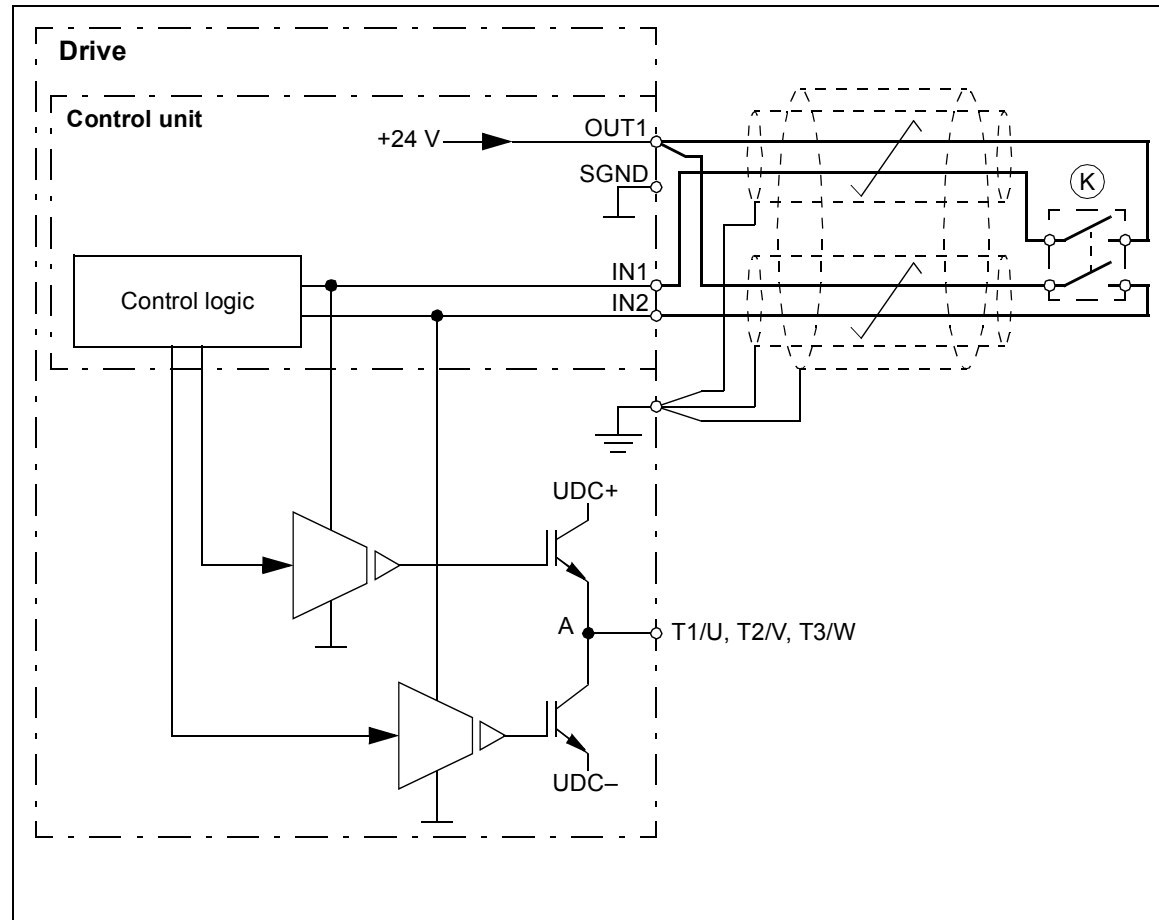

■ Single-channel connection

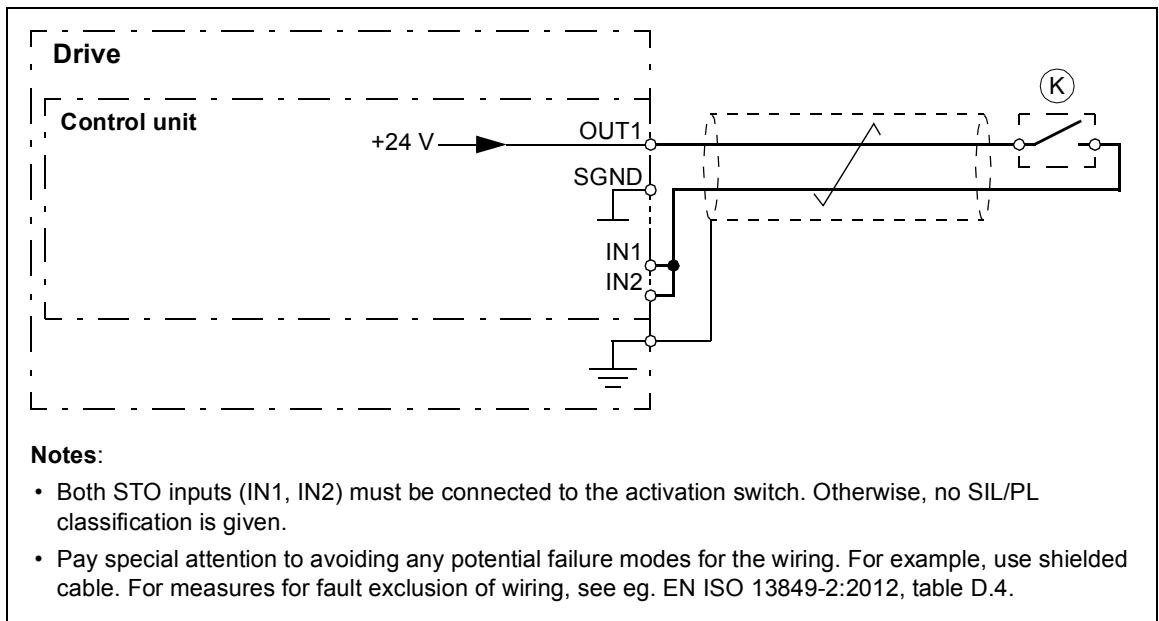

■ Wiring examples

An example of a Safe torque off wiring with internal +24 V DC power supply is shown below.

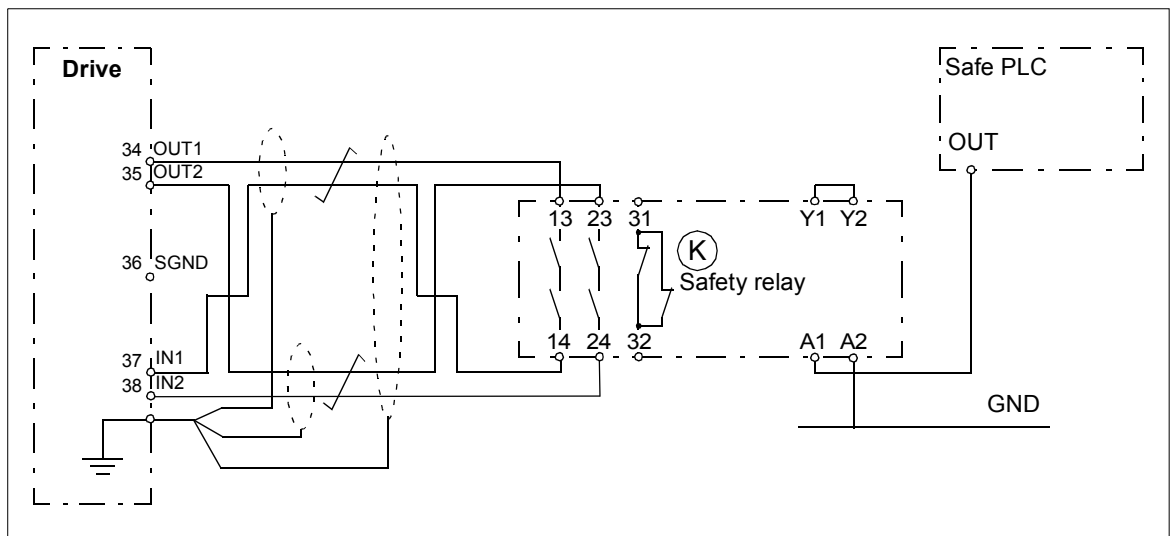

An example of a Safe torque off wiring with external +24 V DC power supply is shown below.

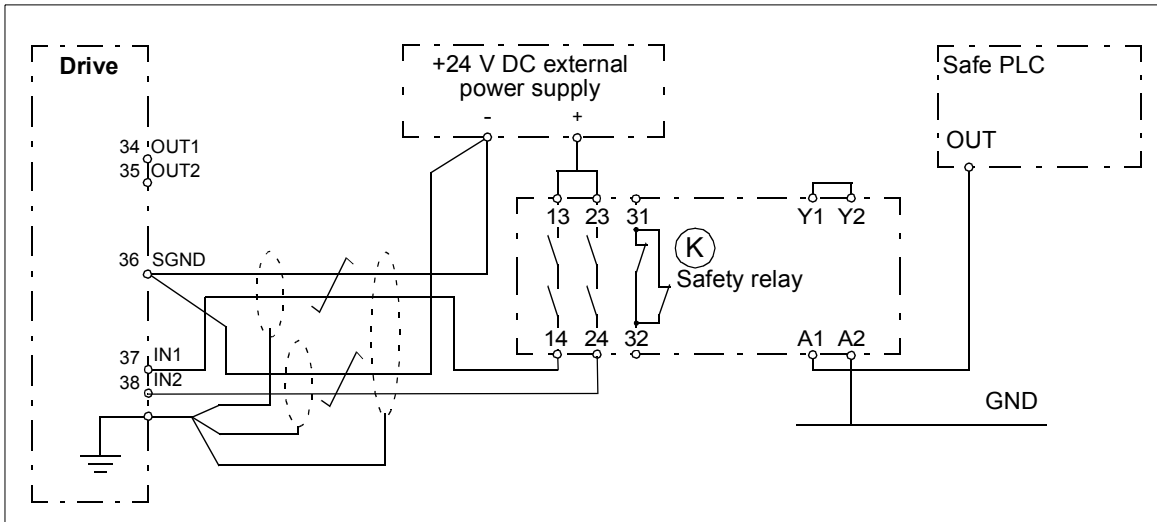

■ Multiple drives (internal power supply)

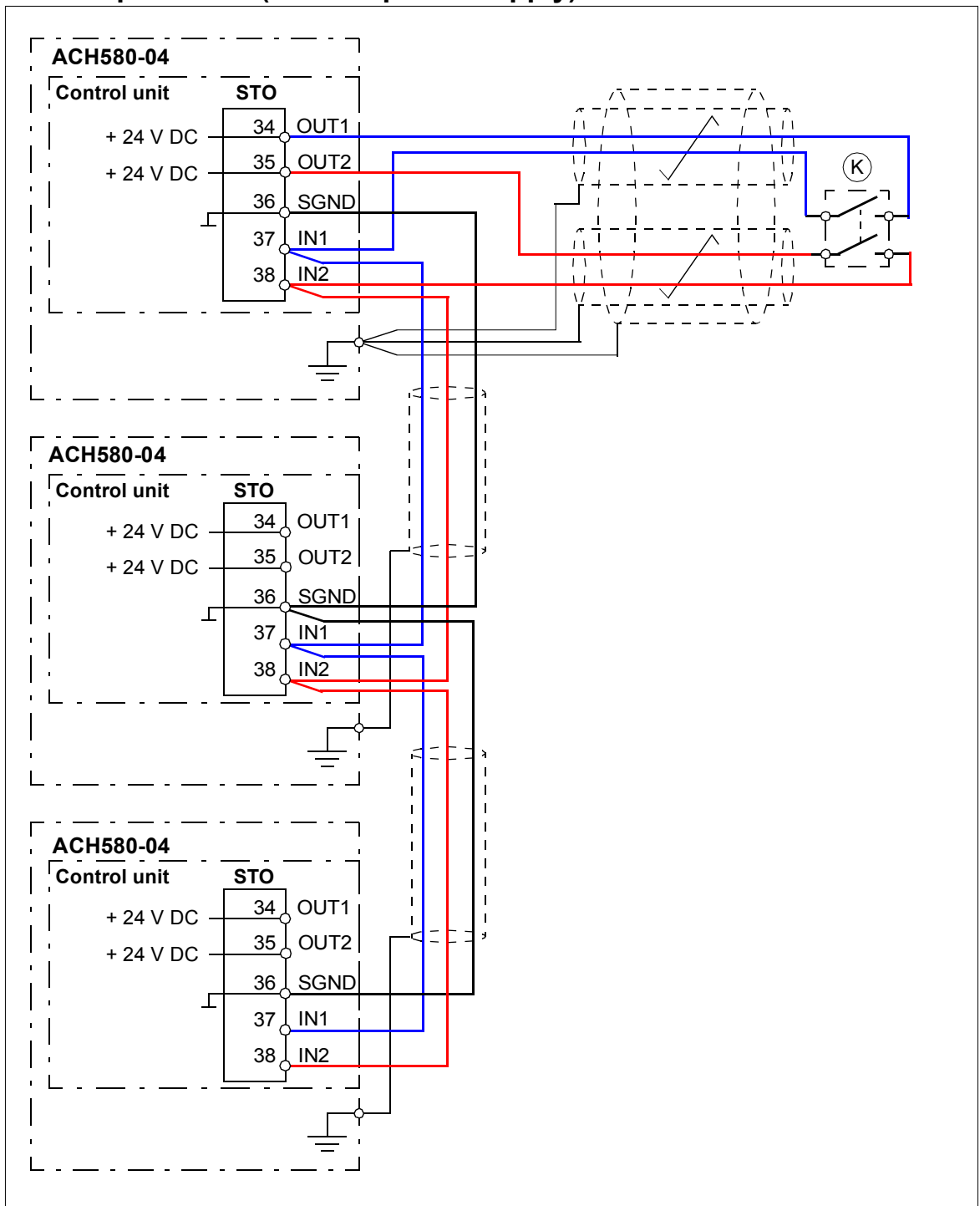

Multiple drives (external power supply)

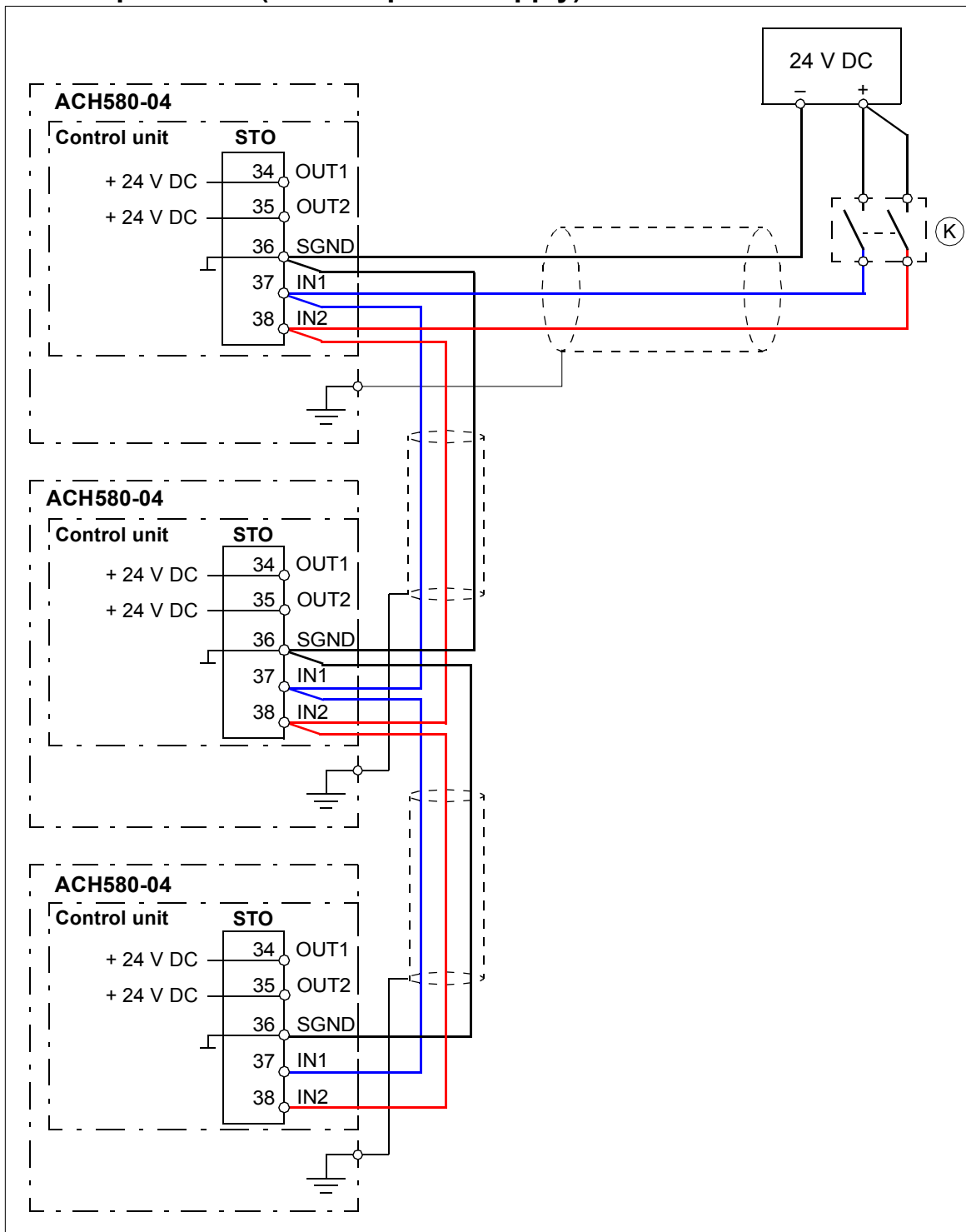

Operation principle

1. The Safe torque off activates (the activation switch is opened, or safety relay contacts open).
2. STO inputs on the drive control unit de-energize.
3. The control unit cuts off the control voltage from the drive IGBTs.
4. The control program generates an indication as defined by parameter **31.22** – see *ACH580 firmware manual (3AXD50000027537[English])*.
5. Motor coasts to a stop (if running). The drive cannot restart while the activation switch or safety relay contacts are open. After the contacts close, a new start command is required to start the drive.

Start-up including acceptance test

To ensure the safe operation of a safety function, validation is required. The final assembler of the machine must validate the function by performing an acceptance test.

The acceptance test must be performed

- at initial start-up of the safety function
- after any changes related to the safety function (circuit boards, wiring, components, settings, etc.)
- after any maintenance work related to the safety function.

■ Competence

The acceptance test of the safety function must be carried out by a competent person with adequate expertise and knowledge of the safety function as well as functional safety, as required by IEC 61508-1 clause 6. The test procedures and report must be documented and signed by this person.

■ Acceptance test reports

Signed acceptance test reports must be stored in the logbook of the machine. The report shall include documentation of start-up activities and test results, references to failure reports and resolution of failures. Any new acceptance tests performed due to changes or maintenance shall be logged into the logbook.

■ Acceptance test procedure

After wiring the Safe torque off function, validate its operation as follows.

Action	<input checked="" type="checkbox"/>
 WARNING! Obey the safety instructions in chapter <i>Safety instructions</i> . Ignoring the instructions can cause physical injury or death, or damage to the equipment.	<input type="checkbox"/>
Make sure that the drive can be run and stopped freely during start-up.	<input type="checkbox"/>
Stop the drive (if running), switch the input power off and isolate the drive from the power line by a disconnecter.	<input type="checkbox"/>
Check the Safe torque off circuit connections against the circuit diagram.	<input type="checkbox"/>
Close the disconnecter and switch the power on.	<input type="checkbox"/>

Action	<input checked="" type="checkbox"/>
<p>Test the operation of the STO function when the motor is stopped.</p> <ul style="list-style-type: none"> • Give a stop command for the drive (if running) and wait until the motor shaft is at a standstill. <p>Make sure that the drive operates as follows:</p> <ul style="list-style-type: none"> • Open the STO circuit. The drive generates an indication if one is defined for 'stopped' state in parameter 31.22 (see the firmware manual). • Give a start command to verify that the STO function blocks the drive operations. The motor should not start. • Close the STO circuit. • Reset any active faults. Restart the drive and check that the motor runs normally. 	<input type="checkbox"/>
<p>Test the operation of the STO function when the motor is running.</p> <ul style="list-style-type: none"> • Start the drive and ensure the motor is running. • Open the STO circuit. The motor should stop. The drive generates an indication if one is defined for 'running' state in parameter 31.22 (see the firmware manual). • Reset any active faults and try to start the drive. • Ensure that the motor stays at a standstill and the drive operates as described above in testing the operation when the motor is stopped. • Close the STO circuit. • Reset any active faults. Restart the drive and check that the motor runs normally. 	<input type="checkbox"/>
<p>Test the operation of the failure detection of the inverter. The motor can be stopped or running.</p> <ul style="list-style-type: none"> • Open the 1st channel of the STO circuit (wire coming to IN1). If the motor was running, it should coast to a stop. The inverter generates a <i>FA81 Safe Torque Off 1 loss</i> fault indication (see the firmware manual). • Give a start command to verify that the STO function blocks the inverter's operation. The motor should not start. • Close the STO circuit. • Reset any active faults. Restart the inverter and check that the motor runs normally. • Open the 2nd channel of the STO circuit (wire coming to IN2). If the motor was running, it should coast to a stop. The inverter generates a <i>FA82 Safe Torque Off 2 loss</i> fault indication (see the firmware manual). • Give a start command to verify that the STO function blocks the inverter's operation. The motor should not start. • Close the STO circuit. • Reset any active faults. Restart the inverter and check that the motor runs normally. 	<input type="checkbox"/>
<p>Document and sign the acceptance test report which verifies that the safety function is safe and accepted for operation.</p>	<input type="checkbox"/>

Use

1. Open the activation switch, or activate the safety functionality that is wired to the STO connection.
 2. STO inputs on the drive control unit de-energize, and the drive control unit cuts off the control voltage from the drive IGBTs.
 3. The control program generates an indication as defined by parameter **31.22** – see *ACH580 firmware manual* (3AXD50000027537 [English]).
 4. Motor coasts to a stop (if running). The drive will not restart while the activation switch or safety relay contacts are open.
 5. Deactivate the STO by closing the activation switch, or resetting the safety functionality that is wired to the STO connection.
 6. Reset any faults before restarting.
-



WARNING! The Safe torque off function does not disconnect the voltage of the main and auxiliary circuits from the drive. Therefore maintenance work on electrical parts of the drive or the motor can only be carried out after isolating the drive from the main supply.



WARNING! (With permanent magnet or synchronous reluctance [SynRM] motors only) In case of a multiple IGBT power semiconductor failure, the drive system can produce an alignment torque which maximally rotates the motor shaft by $180/p$ (with permanent magnet motors) or $180/2p$ (with synchronous reluctance [SynRM] motors) degrees regardless of the activation of the Safe torque off function. p denotes the number of pole pairs.

Notes:

- If a running drive is stopped by using the Safe torque off function, the drive will cut off the motor supply voltage and the motor will coast to a stop. If this causes danger or is not otherwise acceptable, stop the inverter and machinery using the appropriate stop mode before activating the Safe torque off function.
- The Safe torque off function overrides all other functions of the drive.
- The Safe torque off function is ineffective against deliberate sabotage or misuse.
- The Safe torque off function has been designed to reduce the recognized hazardous conditions. In spite of this, it is not always possible to eliminate all potential hazards. The assembler of the machine must inform the final user about the residual risks.

Maintenance

After the operation of the circuit is validated at start-up, the STO function shall be maintained by periodic proof testing. In high demand mode of operation, the maximum proof test interval is 20 years. In low demand mode of operation, the maximum proof test interval is 5 or 2 years; see section [Safety data](#) (page 150). It is assumed that all dangerous failures of the STO circuit are detected by the proof test. To perform the proof test, do the [Acceptance test procedure](#) (page 147).

Note: See also the Recommendation of Use CNB/M/11.050 (published by the European co-ordination of Notified Bodies) concerning dual-channel safety-related systems with electromechanical outputs:

- When the safety integrity requirement for the safety function is SIL 3 or PL e (cat. 3 or 4), the proof test for the function must be performed at least every month.
- When the safety integrity requirement for the safety function is SIL 2 (HFT = 1) or PL d (cat. 3), the proof test for the function must be performed at least every 12 months.

The STO function of the drive does not contain any electromechanical components.

In addition to proof testing, it is a good practice to check the operation of the function when other maintenance procedures are carried out on the machinery.

Include the Safe torque off operation test described above in the routine maintenance program of the machinery that the drive runs.

If any wiring or component change is needed after start-up, or the parameters are restored, follow the test given in section [Acceptance test procedure](#) on page 147.

Use only ABB approved spare parts.

Record all maintenance and proof test activities in the machine logbook.

Competence

The maintenance and proof test activities of the safety function must be carried out by a competent person with adequate expertise and knowledge of the safety function as well as functional safety, as required by IEC 61508-1 clause 6.

Fault tracing

The indications given during the normal operation of the Safe torque off function are selected by drive parameter 31.22.

The diagnostics of the Safe torque off function cross-compare the status of the two STO channels. In case the channels are not in the same state, a fault reaction function is performed and the inverter trips on an “STO hardware failure” fault. An attempt to use the STO in a non-redundant manner, for example activating only one channel, will trigger the same reaction.

See the drive firmware manual for the indications generated by the drive, and for details on directing fault and warning indications to an output on the control unit for external diagnostics.

Any failures of the Safe torque off function must be reported to ABB.

Safety data

Preliminary safety data for the Safe torque off function is given below.

Note: The safety data is calculated for redundant use, and does not apply if both STO channels are not used.

Frame size	SIL/SILCL	SC	PL	SFF (%)	PFH ($T_1 = 20$ a) (1/h)	PFD _{avg} ($T_1 = 2$ a)	PFD _{avg} ($T_1 = 5$ a)	MTTF _D (a)	DC (%)	Cat.	HFT	CCF	Lifetime (a)
$U_1 = 380 \dots 480$ V													
R10, R11	3	3	e	99.88	1.05E-9	1.61E-6	3.94E-06	12779	≥90	3	1	80	20

3AXD00000586715

* According to Table E1 EN/ISO 13849-1

- The following temperature profile is used in safety value calculations:
 - 670 on/off cycles per year with $\Delta T = 71.66$ °C
 - 1340 on/off cycles per year with $\Delta T = 61.66$ °C
 - 30 on/off cycles per year with $\Delta T = 10.0$ °C
 - 32 °C board temperature at 2.0% of time
 - 60 °C board temperature at 1.5% of time
 - 85 °C board temperature at 2.3% of time
- The safety data is calculated for redundant use, and does not apply if both channels are not used.
- The STO is a type A safety component as defined in IEC 61508-2.
- Relevant failure modes:
 - The STO trips spuriously (safe failure)
 - The STO does not activate when requested

A fault exclusion on the failure mode “short circuit on printed circuit board” has been made (EN 13849-2, table D.5). The analysis is based on an assumption that one failure occurs at one time. No accumulated failures have been analyzed.

- STO reaction time (shortest detectable break): 1 ms
- STO response time: 2 ms (typical), 5 ms (maximum)
- Fault detection time: Channels in different states for longer than 200 ms
- Fault reaction time: Fault detection time + 10 ms
- STO fault indication (parameter 31.22) delay: < 500 ms
- STO warning indication (parameter 31.22) delay: < 1000 ms

■ Abbreviations

Abbr.	Reference	Description
Cat.	EN ISO 13849-1	Classification of the safety-related parts of a control system in respect of their resistance to faults and their subsequent behavior in the fault condition, and which is achieved by the structural arrangement of the parts, fault detection and/or by their reliability. The categories are: B, 1, 2, 3 and 4.
CCF	EN/ISO 13849-1	Common cause failure (%)
DC	EN/ISO 13849-1	Diagnostic coverage
FIT	IEC 61508	Failure in time: 1E-9 hours
HFT	IEC 61508	Hardware fault tolerance
MTTF _D	EN/ISO 13849-1	Mean time to dangerous failure: (The total number of life units) / (the number of dangerous, undetected failures) during a particular measurement interval under stated conditions
PFD _{avg}	IEC 61508	Average probability of dangerous failure on demand
PFH	IEC 61508	Average frequency of dangerous failures per hour
PL	EN/ISO 13849-1	Performance level. Levels a...e correspond to SIL
SC	IEC 61508	Systematic capability
SFF	IEC 61508	Safe failure fraction (%)
SIL	IEC 61508	Safety integrity level (1...3)
SILCL	IEC/EN 62061	Maximum SIL (level 1...3) that can be claimed for a safety function or subsystem
SS1	EN 61800-5-2	Safe stop 1
STO	EN 61800-5-2	Safe torque off
T1	IEC 61508-6	Proof test interval. T1 is a parameter used to define the probabilistic failure rate (PFH or PFD) for the safety function or subsystem. Performing a proof test at a maximum interval of T1 is required to keep the SIL capability valid. The same interval must be followed to keep the PL capability (EN ISO 13849) valid. Note that any T1 values given cannot be regarded as a guarantee or warranty. See also section Maintenance (page 105).

■ Declaration of conformity

Power and productivity
for a better world™



EU Declaration of Conformity

Machinery Directive 2006/42/EC

We

Manufacturer: ABB Oy
Address: Hiomotie 13, 00380 Helsinki, Finland.
Phone: +358 10 22 11

declare under our sole responsibility that the following product:

Frequency converter

ACH580-04

with regard to the safety function

Safe torque off

is in conformity with all the relevant safety component requirements of EU Machinery Directive 2006/42/EC, when the listed safety function is used for safety component functionality.

The following harmonized standards have been applied:

EN 61800-5-2:2007	<i>Adjustable speed electrical power drive systems – Part 5-2: Safety requirements - Functional</i>
EN 62061:2005 + AC:2010 + A1:2013 + A2:2015	<i>Safety of machinery – Functional safety of safety-related electrical, electronic and programmable electronic control systems</i>
EN ISO 13849-1:2015	<i>Safety of machinery – Safety-related parts of control systems. Part 1: General requirements</i>
EN ISO 13849-2:2012	<i>Safety of machinery – Safety-related parts of the control systems. Part 2: Validation</i>
EN 60204-1: 2006 + A1:2009 + AC:2010	<i>Safety of machinery – Electrical equipment of machines – Part 1: General requirements</i>

The following other standards have been applied:

IEC 61508:2010	<i>Functional safety of electrical / electronic / programmable electronic safety-related systems</i>
IEC 61800-5-2:2016	<i>Adjustable speed electrical power drive systems – Part 5-2: Safety requirements - Functional</i>

Union Directives which are notified in Single EU Declaration of conformity 3AXD10000497691.

Person authorized to compile the technical file:

Name and address: Risto Mynttinen, Hiomotie 13, 00380 Helsinki, Finland.

Helsinki, 10 May 2017

Manufacturer representative:

Vesa Kandell
Vice President, ABB Oy

16

Optional I/O extension modules

Contents of this chapter

This chapter describes how to install and start up the optional CHDI-01, CMOD-01 and CMOD-02 IO extension modules. The chapter also contains their diagnostics and technical data.

CHDI-01 115/230 V digital input extension module

- **Safety instructions**



WARNING! Obey the safety instructions for the drive. If you ignore the safety instructions, injury or death can occur.

- **Hardware description**

Product overview

The CHDI-01 115/230 V digital input extension module expands the inputs of the drive control unit. It has six high voltage inputs and two relay outputs.

Layout

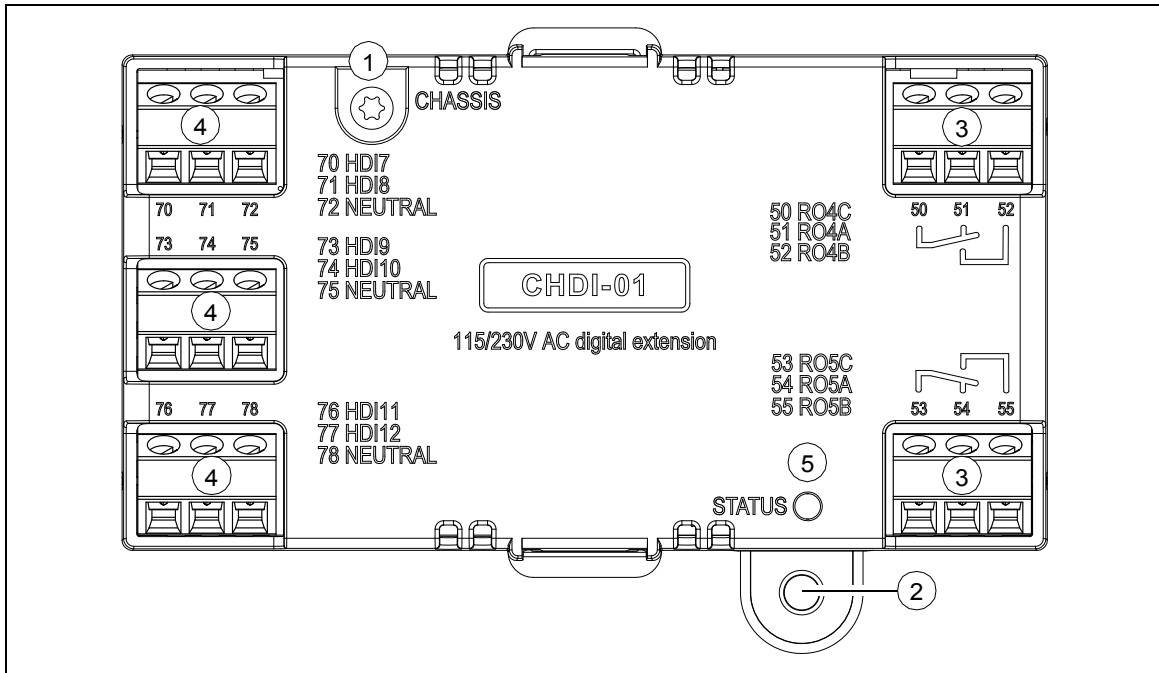

Item	Description	Additional information
1	Grounding screw	-
2	Hole for mounting screw	-
3	3-pin terminal blocks for relay outputs	Page 155
4	3-pin terminal block for 115/230 V inputs	Page 155
5	Diagnostic LED	Page 157

■ Mechanical installation

Necessary tools and instructions

- Screwdriver and a set of suitable bits.

Unpacking and checking the delivery

1. Open the option package.
2. Make sure that the package contains:
 - CHDI-01 high voltage digital extension module
 - mounting screw.
3. Make sure that there are no signs of damage.

Installing the module

See chapter [Installing option modules](#) on page [89](#).

■ Electrical installation

Warnings



WARNING! Obey the instructions in chapter [Safety instructions](#) on page 13. If you ignore them, injury or death, or damage to the equipment can occur. If you are not a qualified electrician, do not do electrical work.

Make sure that the drive is disconnected from the input power during installation. If the drive is already connected to the input power, wait for 5 minutes after disconnecting the input power.

Necessary tools and instructions

- Screwdriver and a set of suitable bits
- Cabling tools

Terminal designations

For more detailed information on the connectors, see section [Technical data](#) on page 164.

Relay outputs

Marking		Description
50	RO4C	Common, C
51	RO4A	Normally closed, NC
52	RO4B	Normally open, NO
53	RO5C	Common, C
54	RO5A	Normally closed, NC
55	RO5B	Normally open, NO

115/230 V inputs

Marking		Description
70	HDI7	115/230 V input 1
71	HDI8	115/230 V input 2
72	NEUTRAL	Neutral point
73	HDI9	115/230 V input 3
74	HDI10	115/230 V input 4
75	NEUTRAL	Neutral point
76	HDI11	115/230 V input 5
77	HDI12	115/230 V input 6
78	NEUTRAL	Neutral point

¹⁾ Neutral points 72, 75 and 78 are connected.

General cabling instructions

Obey the instructions given in chapter [Guidelines for planning the electrical installation](#) on page 51.

Wiring

Connect the external control cables to the applicable module terminals. Ground the outer shield of the cables 360 degrees under a grounding clamp next to the control unit.

Relay output connection example

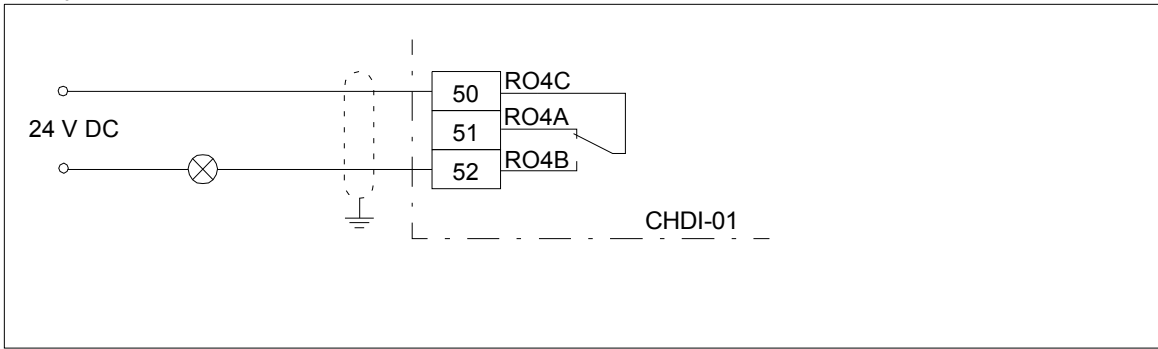

Digital input connection example

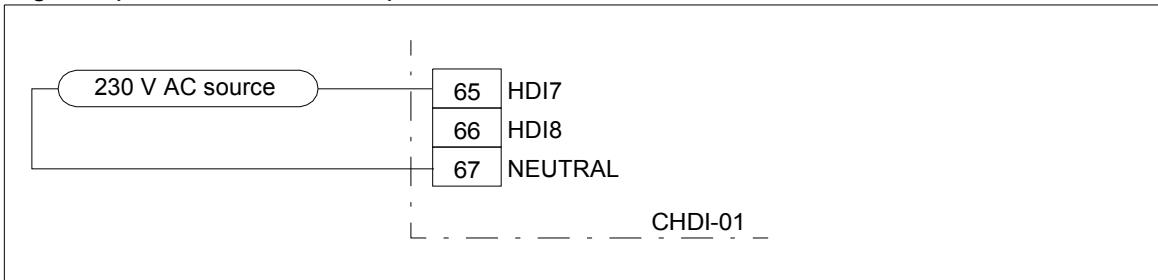

■ Start-up

Setting the parameters

1. Power up the drive.
2. If no warning is shown,
 - make sure that the value of both parameter 15.02 Detected extension module and parameter 15.01 Extension module type is CHDI-01.
 If warning A7AB Extension I/O configuration failure is shown,
 - make sure that the value of parameter 15.02 Detected extension module is CHDI-01.
 - set parameter 15.01 Extension module type to CHDI-01.
 You can now see the parameters of the extension module in parameter group 15 I/O extension module.
3. Set the parameters of the extension module to applicable values.

Parameter setting example for relay output

This example shows how to make relay output RO4 of the extension module indicate the reverse direction of rotation of the motor with a one-second delay.

Parameter	Setting
15.07 RO4 source	Reverse
15.08 RO4 ON delay	1 s
15.09 RO4 OFF delay	1 s

■ Diagnostics

Faults and warning messages

Warning A7AB Extension I/O configuration failure.

LEDs

The extension module has one diagnostic LED.

Color	Description
Green	The extension module is powered up.

■ Technical data

Dimension drawing:

The dimensions are in millimeters and [inches].

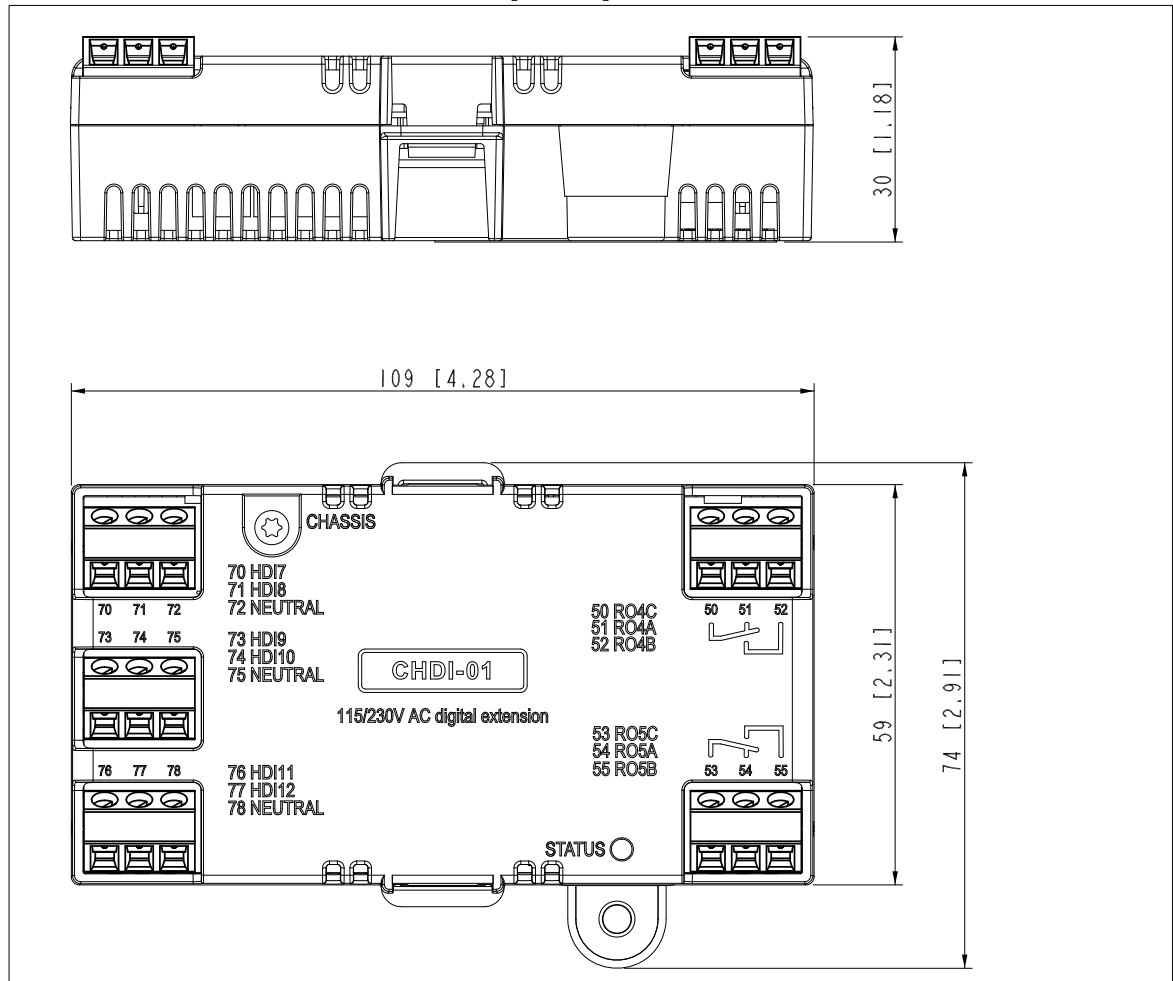

Installation: Into an option slot on the drive control unit

Degree of protection: IP20

Ambient conditions: See the drive technical data.

Package: Cardboard

Isolation areas:

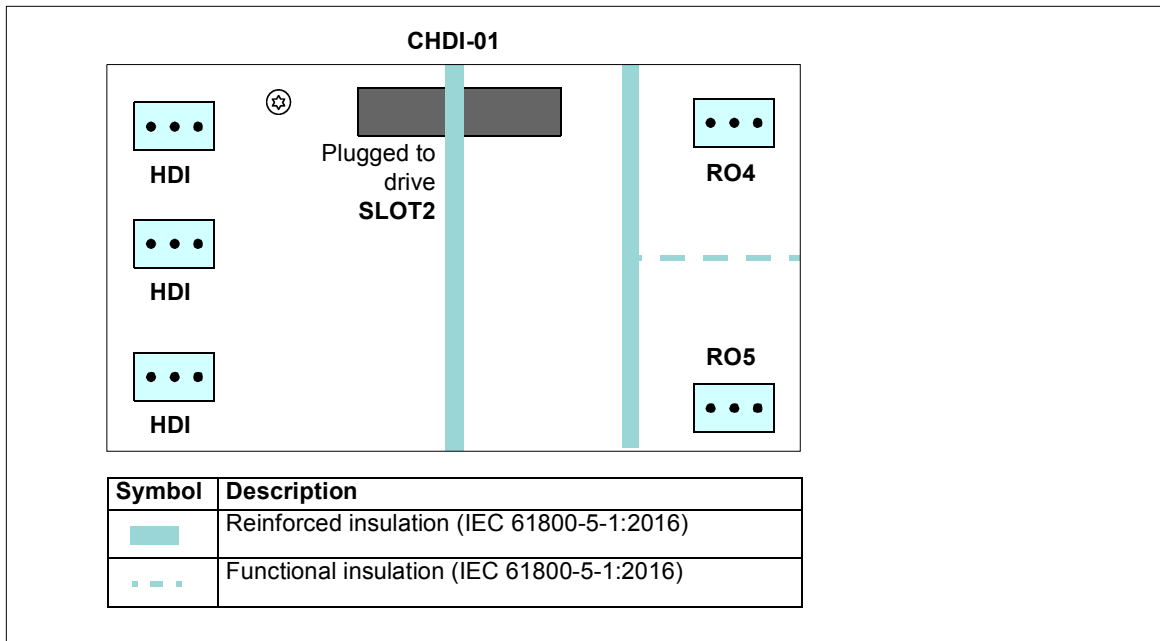

Relay outputs (50...52, 53...55):

- Wire size max. 1.5 mm²
- Minimum contact rating: 12 V / 10 mA
- Maximum contact rating: 250 V AC / 30 V DC / 2 A
- Maximum breaking capacity: 1500 VA

115/230 V inputs (70...78):

- Wire size max. 1.5 mm²
- Input voltage: 115 to 230 V AC $\pm 10\%$
- Maximum current leakage in digital off state: 2 mA

CMOD-01 multifunction extension module (external 24 V AC/DC and digital I/O)

■ Safety instructions



WARNING! Obey the safety instructions for the drive. If you ignore the safety instructions, injury or death can occur.

■ Hardware description

Product overview

The CMOD-01 multifunction extension module (external 24 V AC/DC and digital I/O) expands the outputs of the drive control unit. It has two relay outputs and one transistor output, which can function as a digital or frequency output.

In addition, the extension module has an external power supply interface, which can be used to power up the drive control unit in case the drive power supply fails. If you do not need the back-up power supply, you do not have to connect it because the module is powered from the drive control unit by default.



WARNING! Do not connect the +24 V AC cable to the control unit ground when the control unit is powered using an external 24 V AC supply.

Layout

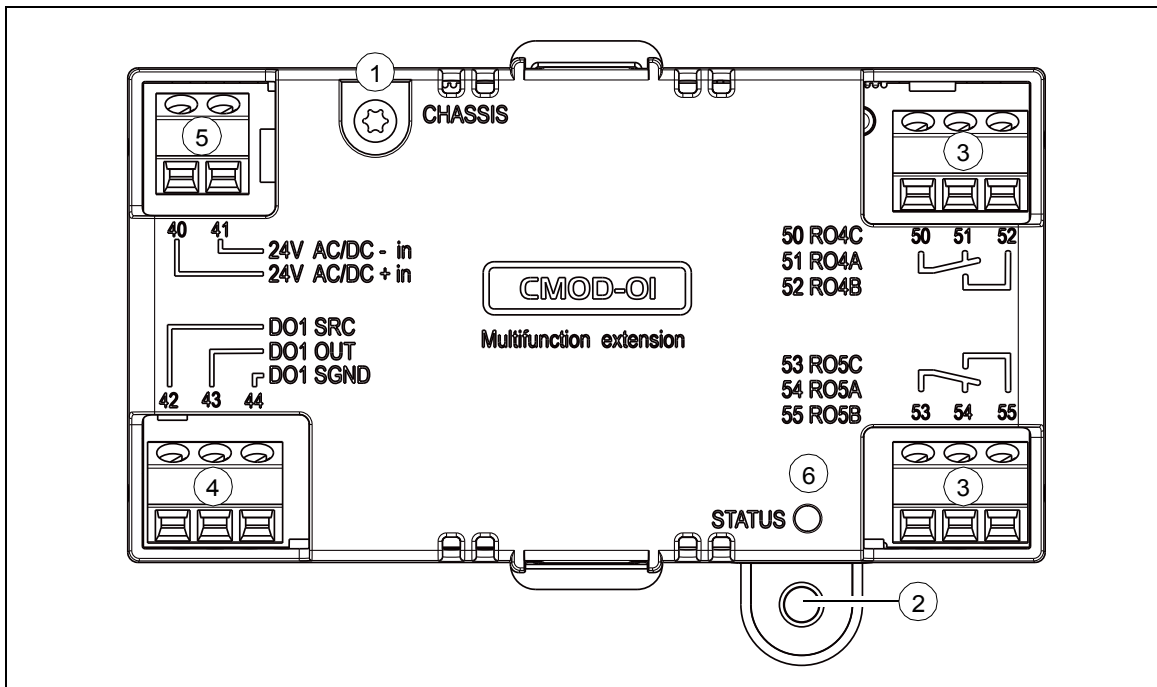

Item	Description	Additional information
1	Grounding screw	-
2	Hole for mounting screw	-
3	3-pin terminal blocks for relay outputs	Page 161
4	3-pin terminal block for transistor output	Page 161
5	2-pin terminal block for external power supply	Page 161
6	Diagnostic LED	Page 164

Mechanical installation

Necessary tools and instructions

- Screwdriver and a set of suitable bits.

Unpacking and checking the delivery

1. Open the option package.
2. Make sure that the package contains:
 - CMOD-01 multifunction extension module
 - mounting screw.
3. Make sure that there are no signs of damage.

Installing the module

See chapter [Installing option modules](#) on page [89](#).

■ Electrical installation

Warnings



WARNING! Obey the instructions in chapter [Safety instructions](#) on page 13. If you ignore them, injury or death, or damage to the equipment can occur. If you are not a qualified electrician, do not do electrical work.

Make sure that the drive is disconnected from the input power during installation. If the drive is already connected to the input power, wait for 5 minutes after disconnecting the input power.

Necessary tools and instructions

- Screwdriver and a set of suitable bits
- Cabling tools

Terminal designations

For more detailed information on the connectors, see section [Technical data](#) on page 164.

Relay outputs

Marking	Description
50	RO4C Common, C
51	RO4A Normally closed, NC
52	RO4B Normally open, NO
53	RO5C Common, C
54	RO5A Normally closed, NC
55	RO5B Normally open, NO

Transistor output

Marking	Description
42	DO1 SRC Source input
43	DO1 OUT Digital or frequency output
44	DO1 SGND Ground (earth) potential

External power supply

The external power supply is needed only if you want to connect an external back-up power supply for the drive control unit. The control unit has corresponding terminals 40 and 41 for external power supply connection

Marking	Description
40	24V AC/DC + in External 24 V (AC/DC) input
41	24V AC/DC - in External 24 V (AC/DC) input

General cabling instructions

Obey the instructions given in chapter [Guidelines for planning the electrical installation](#) on page 51.

Wiring

Connect the external control cables to the applicable module terminals. Ground the outer shield of the cables 360 degrees under a grounding clamp next to the control unit.

Relay output connection example

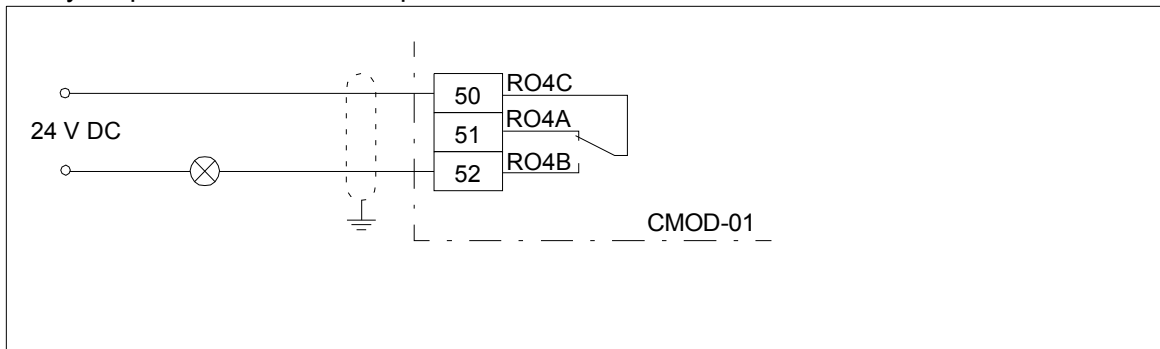

Digital output connection example

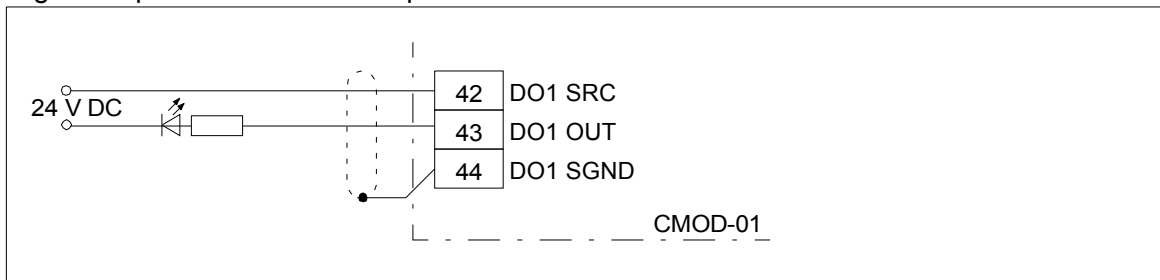

Frequency output connection example

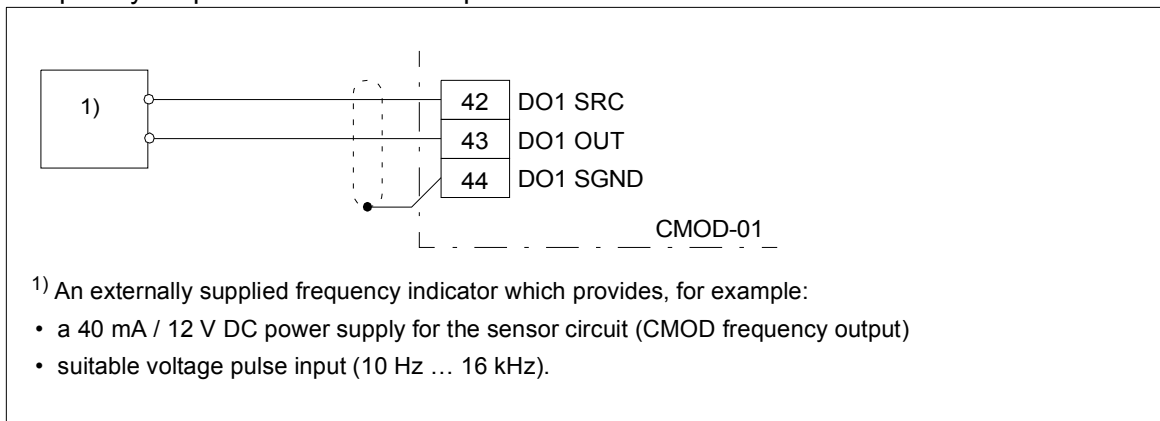

External power supply connection example

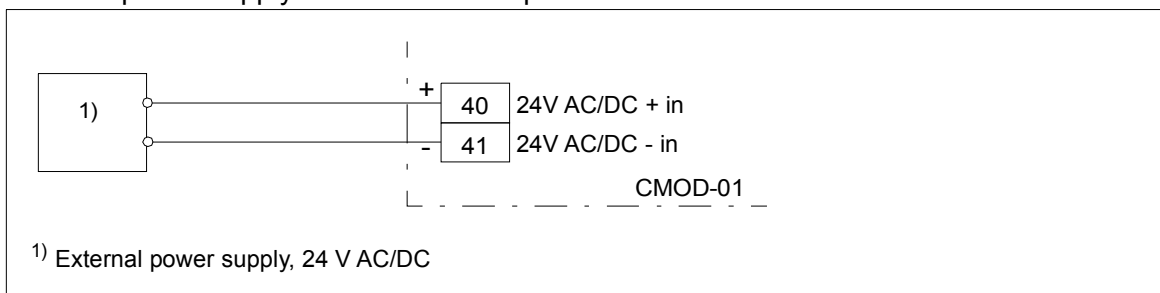

WARNING! Do not connect the +24 V AC cable to the control unit ground when the control unit is powered using an external 24 V AC supply.

■ Start-up

Setting the parameters

1. Power up the drive.
2. If no warning is shown,
 - make sure that the value of both parameter 15.02 Detected extension module and parameter 15.01 Extension module type is CMOD-01.

If warning A7AB Extension I/O configuration failure is shown,

- make sure that the value of parameter 15.02 Detected extension module is CMOD-01.
- set parameter 15.01 Extension module type to CMOD-01.

You can now see the parameters of the extension module in parameter group 15 I/O extension module.

3. Set the parameters of the extension module to applicable values.

Examples are given below.

Parameter setting example for relay output

This example shows how to make relay output RO4 of the extension module indicate the reverse direction of rotation of the motor with a one-second delay.

Parameter	Setting
15.07 RO4 source	Reverse
15.08 RO4 ON delay	1 s
15.09 RO4 OFF delay	1 s

Parameter setting example for digital output

This example shows how to make digital output DO1 of the extension module indicate the reverse direction of rotation of the motor with a one-second delay.

Parameter	Setting
15.22 DO1 configuration	Digital output
15.23 DO1 source	Reverse
15.24 DO1 ON delay	1 s
15.25 DO1 OFF delay	1 s

Parameter setting example for frequency output

This example shows how to make digital output DO1 of the extension module indicate the motor speed 0... 1500 rpm with a frequency range of 0...10000 Hz.

Parameter	Setting
15.22 DO1 configuration	Frequency output
15.33 Freq out 1 source	01.01
15.34 Freq out 1 src min	0
15.35 Freq out 1 src max	1500.00
15.36 Freq out 1 at src min	1000 Hz
15.37 Freq out 1 at src max	10000 Hz

■ Diagnostics

Faults and warning messages

Warning A7AB Extension I/O configuration failure.

LEDs

The extension module has one diagnostic LED.

Color	Description
Green	The extension module is powered up.

Technical data

Dimension drawing:

The dimensions are in millimeters and [inches].

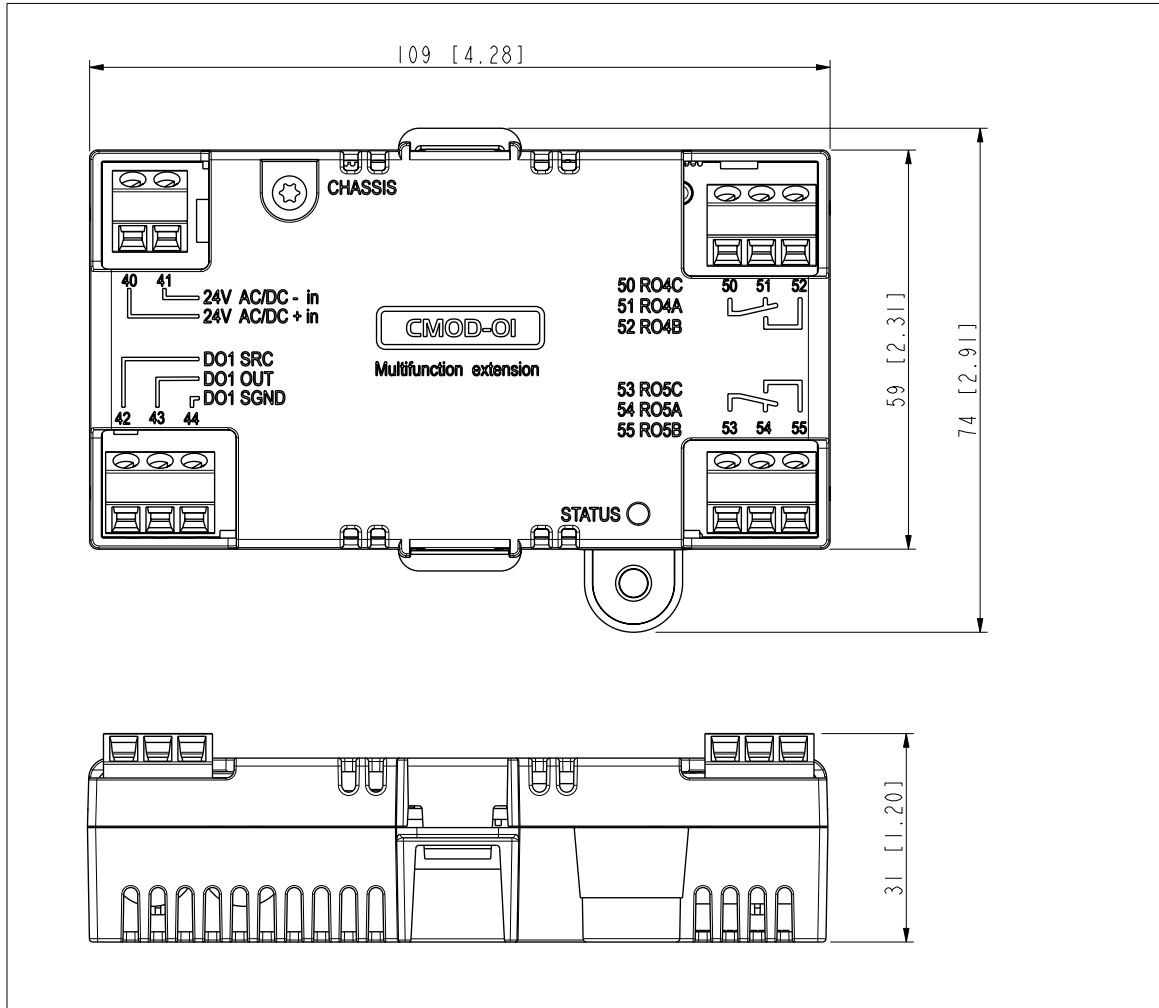

Installation: Into an option slot on the drive control unit

Degree of protection: IP20

Ambient conditions: See the drive technical data.

Package: Cardboard

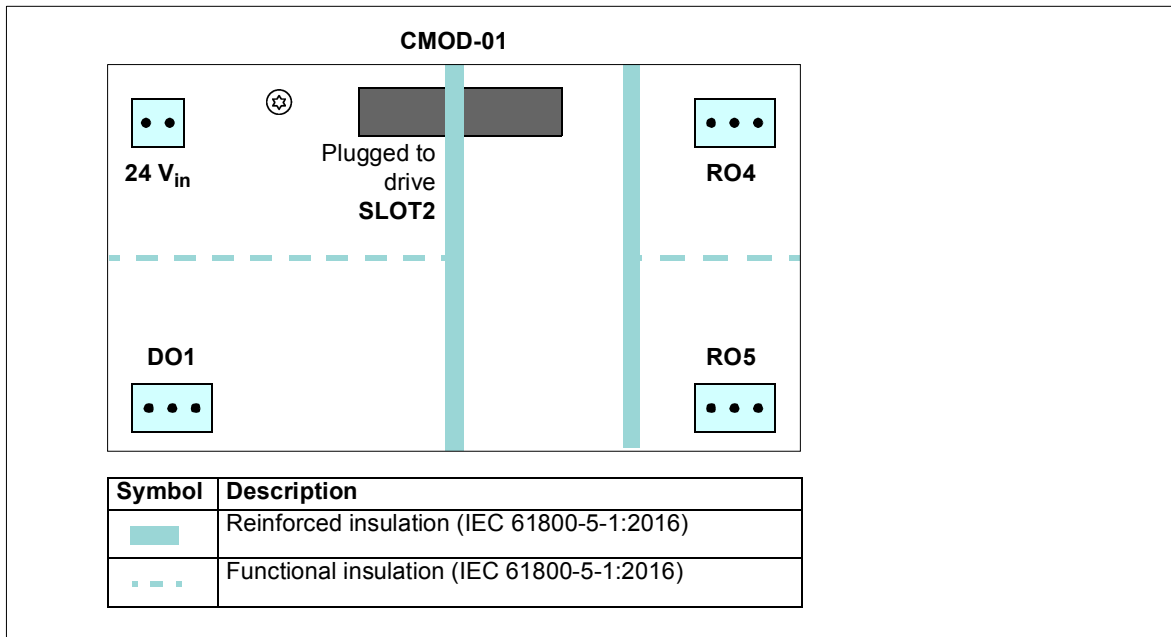
Isolation areas:**Relay outputs (50...52, 53...55):**

- Wire size max. 1.5 mm²
- Minimum contact rating: 12 V / 10 mA
- Maximum contact rating: 250 V AC / 30 V DC / 2 A
- Maximum breaking capacity: 1500 VA

Transistor output (42...44):

- Wire size max. 1.5 mm²
- Type: Transistor output PNP
- Maximum load: 4 kohm
- Maximum switching voltage: 30 V DC
- Maximum switching current: 100 mA / 30 V DC, short-circuit protected
- Frequency: 10 Hz ... 16 kHz
- Resolution: 1 Hz
- Inaccuracy: 0.2%

External power supply (40...41):

- Wire size max. 1.5 mm²
- 24 V AC / V DC ±10% (GND, user potential)
- Maximum current consumption: 25 W, 1.04 A at 24 V DC

CMOD-02 multifunction extension module (external 24 V AC/DC and isolated PTC interface)

■ **Safety instructions**



WARNING! Obey the safety instructions for the drive. If you ignore the safety instructions, injury or death can occur.

■ **Hardware description**

Product overview

The CMOD-02 multifunction extension module (external 24 V AC/DC and isolated PTC interface) has a motor thermistor connection for supervising the motor temperature and one relay output, which indicates the thermistor status. To trip the drive, the user must connect this overtemperature indication back to the drive, for example, to its Safe torque off input.

In addition, the extension module has an external power supply interface, which can be used to power up the drive control unit in case the drive power supply fails. If you do not need the back-up power supply, you do not have to connect it because the module is powered from the drive control unit by default.

There is reinforced insulation between the motor thermistor connection, the relay output and the drive control unit interface. Thus, you can connect a motor thermistor to the drive through the extension module.



WARNING! Do not connect the +24 V AC cable to the control unit ground when the control unit is powered using an external 24 V AC supply.

Layout

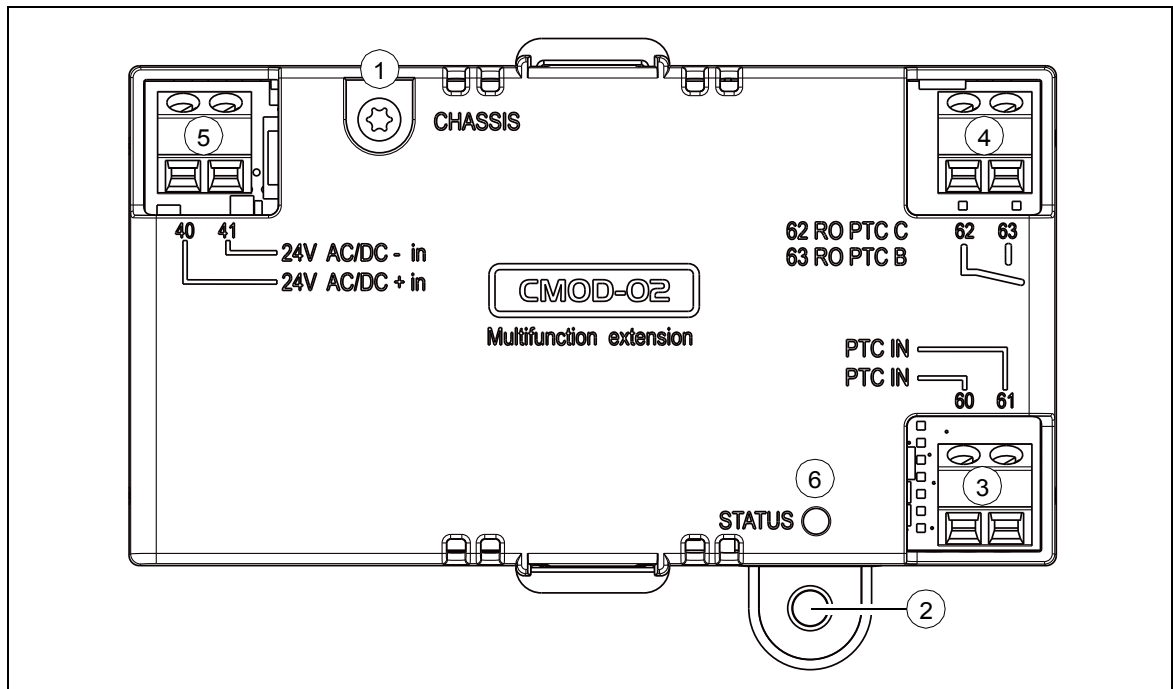

Item	Description	Additional information
1	Grounding screw	-
2	Hole for mounting screw	-
3	2-pin terminal block for motor thermistor connection	Page 168
4	2-pin terminal block for relay output	Page 168
5	2-pin terminal block for external power supply	Page 168
6	Diagnostic LED	Page 170

■ Mechanical installation

Necessary tools and instructions

- Screwdriver and a set of suitable bits

Unpacking and checking the delivery

1. Open the option package.
2. Make sure that the package contains:
 - CMOD-02 multifunction extension module
 - mounting screw
3. Make sure that there are no signs of damage.

Installing the module

See chapter [Installing option modules](#) on page [89](#).

■ Electrical installation

Warnings



WARNING! Obey the instructions in chapter [Safety instructions](#) on page 13. If you ignore them, injury or death, or damage to the equipment can occur. If you are not a qualified electrician, do not do electrical work.

Make sure that the drive is disconnected from the input power during installation. If the drive is already connected to the input power, wait for 5 minutes after disconnecting the input power.

Necessary tools and instructions

- Screwdriver and a set of suitable bits
- Cabling tools

Terminal designations

For more detailed information on the connectors, see section [Technical data](#) on page 170.

Motor thermistor connection

Marking		Description
60	PTC IN	PTC connection
61	PTC IN	Ground (earth) potential

Relay output

Marking		Description
62	RO PTC C	Common, C
63	RO PTC B	Normally open, NO

External power supply

The external power supply is needed only if you want to connect an external back-up power supply for the drive control unit. The control unit has corresponding terminals 40 and 41 for external power supply connection.

Marking		Description
40	24V AC/DC + in	External 24 V (AC/DC) input
41	24V AC/DC - in	External 24 V (AC/DC) input

General cabling instructions

Obey the instructions given in chapter [Guidelines for planning the electrical installation](#) on page 51.

Wiring

Connect the external control cables to the applicable module terminals. Ground the outer shield of the cables 360 degrees under a grounding clamp next to the control unit.

Motor thermistor connection example

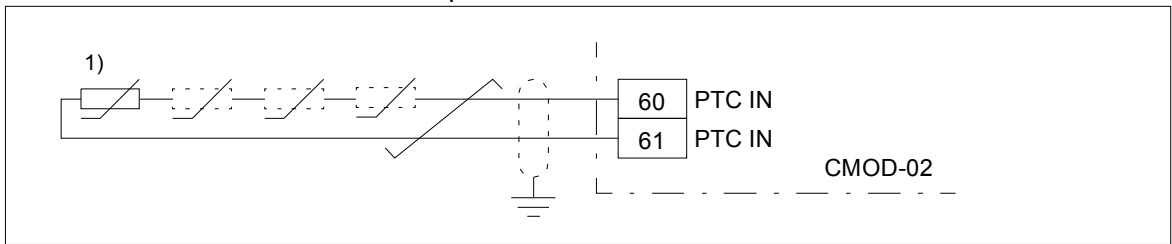

1) One or 3...6 PTC thermistors connected in series.

The PTC input is reinforced/double insulated. If the motor part of the PTC sensor and wiring are reinforced/double insulated, voltages on the PTC wiring are within SELV limits.

If the motor PTC circuit is not reinforced/double insulated (ie, it is basic insulated), it is mandatory to use reinforced/double insulated wiring between the motor PTC and CMOD-02 PTC terminal.

Relay output connection example

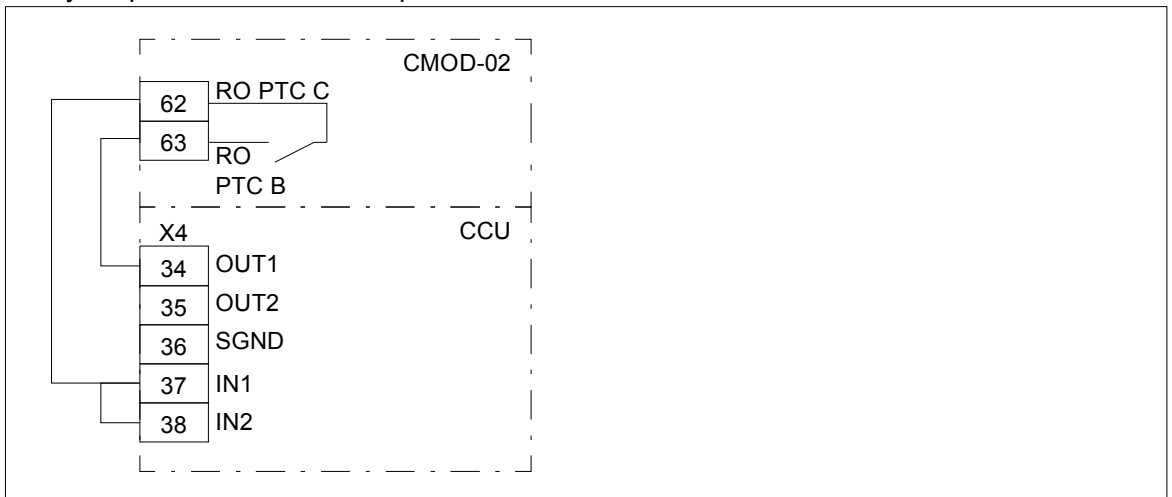

Power supply connection example

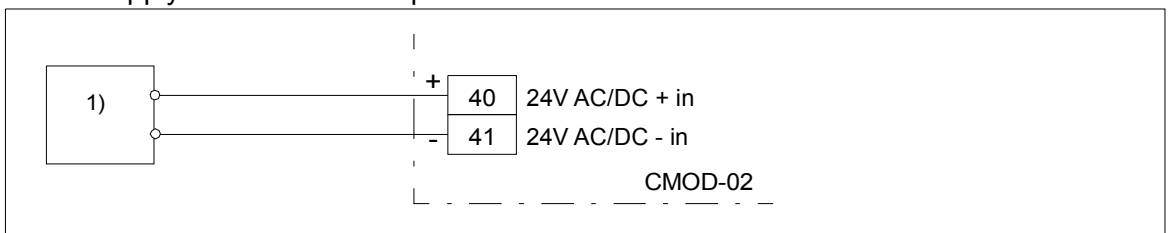

1) External power supply, 24 V AC/DC



WARNING! Do not connect the +24 V AC cable to the control unit ground when the control unit is powered using an external 24 V AC supply.

■ Start-up

Setting the parameters

1. Power up the drive.
2. If no warning is shown,
 - make sure that the value of both parameter 15.02 Detected extension module and parameter 15.01 Extension module type is CMOD-02.

If warning A7AB Extension I/O configuration failure is shown,

- make sure that the value of parameter 15.02 Detected extension module is CMOD-02.
- set parameter 15.01 Extension module type to CMOD-02.

You can now see the parameters of the extension module in parameter group 15 I/O extension module.

■ Diagnostics

Faults and warning messages

Warning A7AB Extension I/O configuration failure.

LEDs

The extension module has one diagnostic LED.

Color	Description
Green	The extension module is powered up.

■ Technical data

Dimension drawing:

The dimensions are in millimeters and [inches].

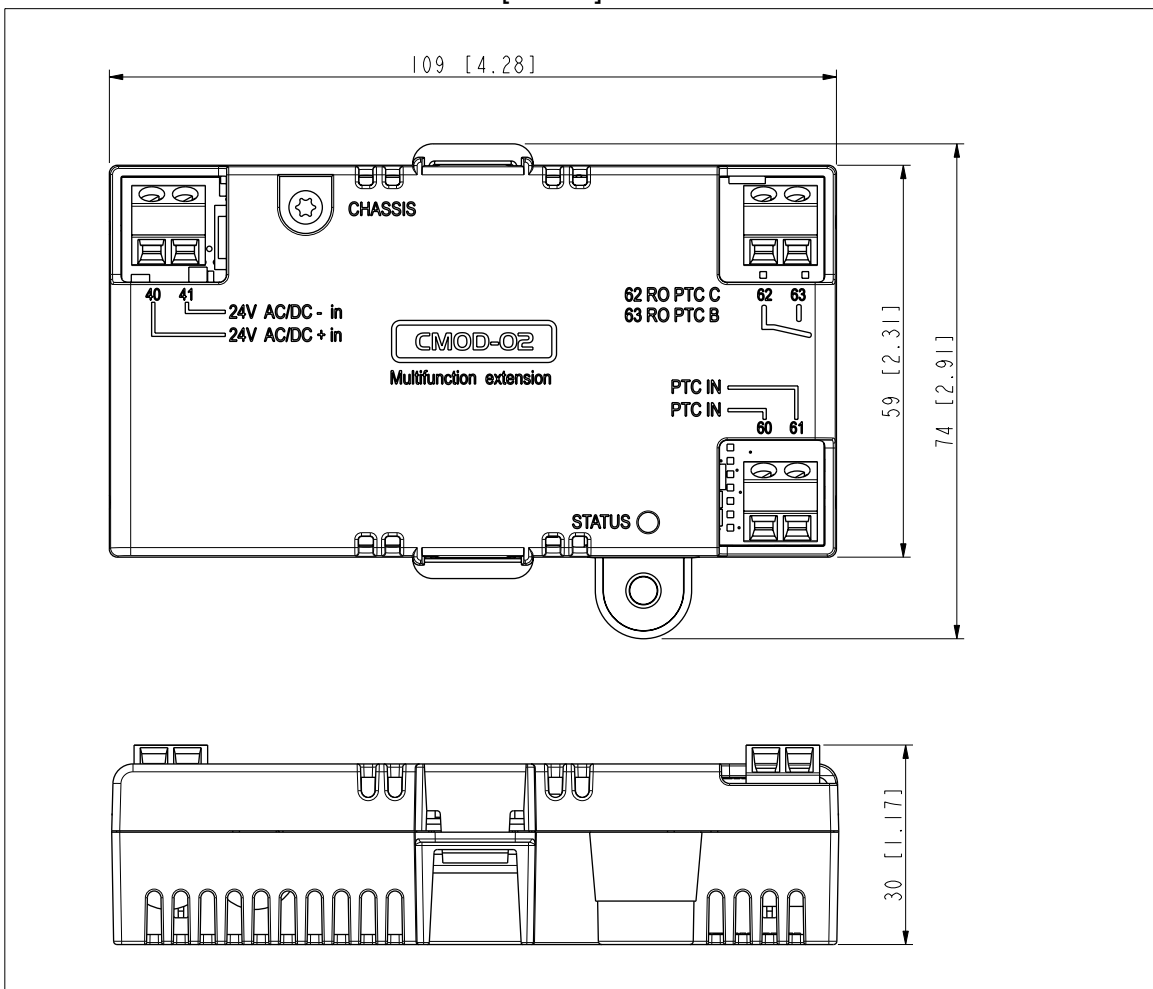

Installation: Into an option slot on the drive control unit

Degree of protection: IP20

Ambient conditions: See the drive technical data.

Package: Cardboard

Isolation areas:

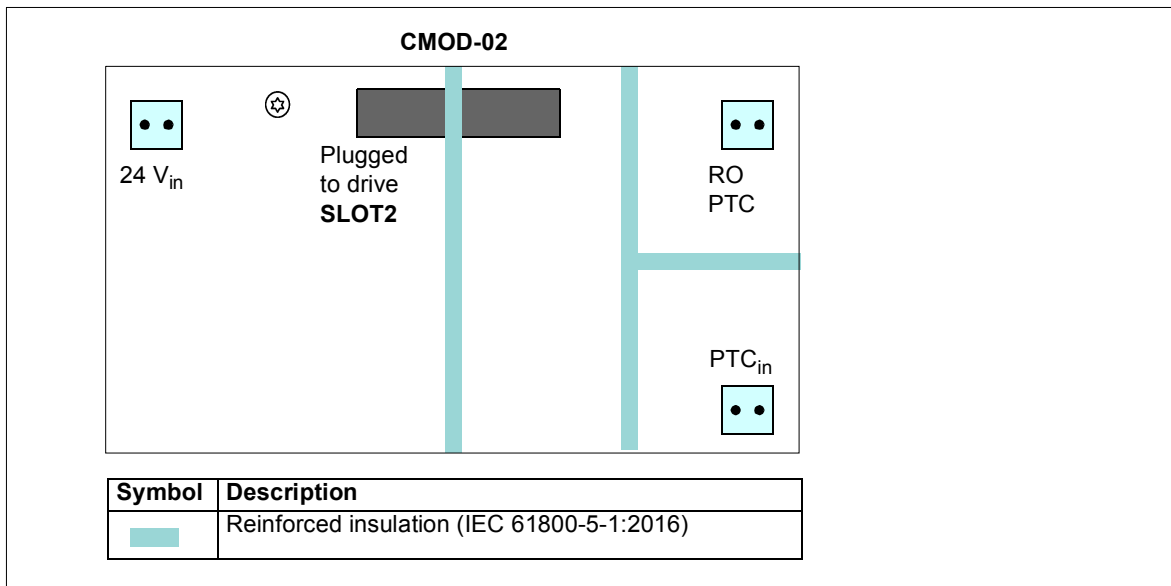

Motor thermistor connection (60...61):

- Wire size max. 1.5 mm²
- Supported standards: DIN 44081 and DIN 44082
- Number of PTC thermistor relays: 1 or 3...6 in series
- Triggering threshold: 3.6 kohm
- Recovery threshold: 1.6 kohm
- PTC terminal voltage: ≤ 5.0 V
- PTC terminal current: < 1 mA
- Short-circuit detection: < 50 ohm

Relay output (62...63):

- Wire size max. 1.5 mm²
- Maximum contact rating: 250 V AC / 30 V DC / 5 A
- Maximum breaking capacity: 1000 VA

External power supply (40...41):

- Wire size max. 1.5 mm²
- 24 V AC / V DC $\pm 10\%$ (GND, user potential)
- Maximum current consumption: 25 W, 1.04 A at 24 V DC

CPTC-02 ATEX-certified thermistor protection module, (external 24 V AC/DC and isolated PTC interface)

See *CPTC-02 ATEX-certified thermistor protection module, Ex II (2) GD (+L537+Q971) user's manual* (3AXD50000030058 [English]).

17

du/dt filters

Contents of this chapter

This chapter describes how to select *du/dt* filters for the drive.

du/dt filters

■ When is *du/dt* filter needed?

See section [Examining the compatibility of the motor and drive](#), page 52.

■ Selection table

Contact ABB.

du/dt filter types for the drive module types are given below.

Frame	<i>du/dt</i> filter type
R10	FOCH0610-70
R11	FOCH0875-70

3AXD00000586715

■ Ordering codes

Filter type	ABB ordering code
FOCH-0610-70	68550483
FOCH-0875-70	3AUA0000125245

■ Description, installation and technical data of the FOCH filters

See *FOCH du/dt filters hardware manual* (3AFE68577519 [English]).

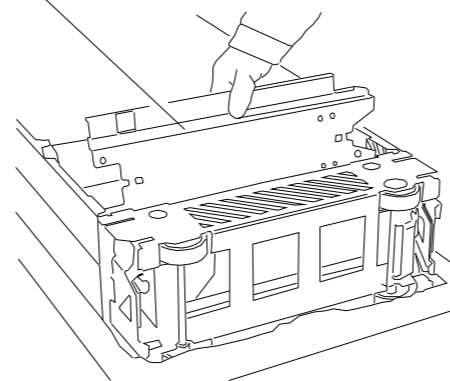
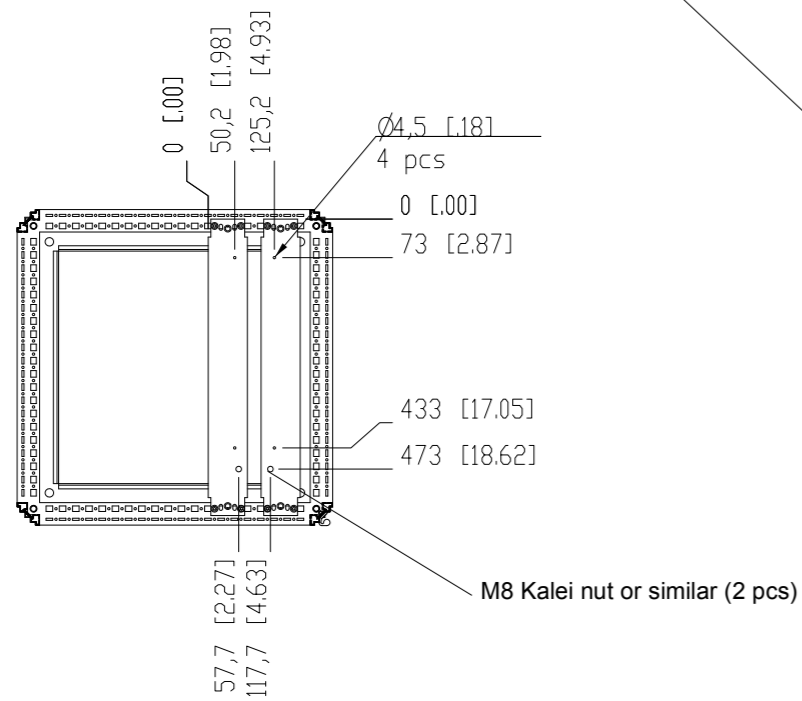
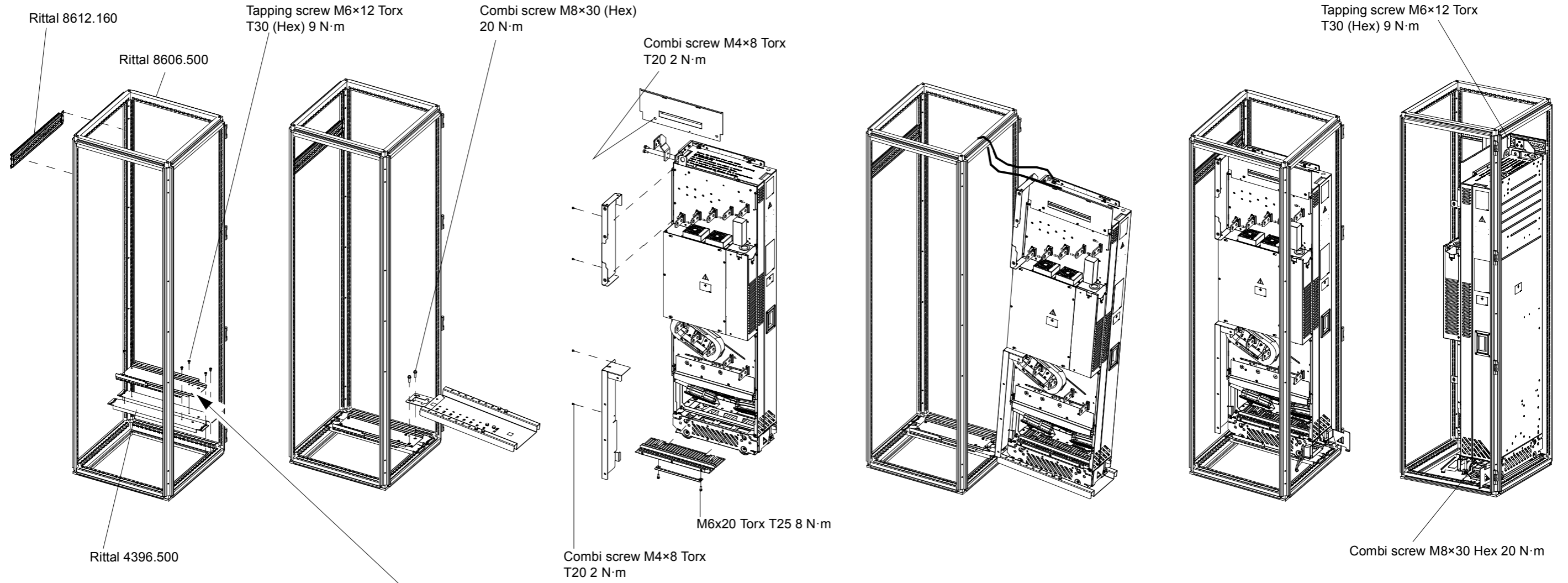

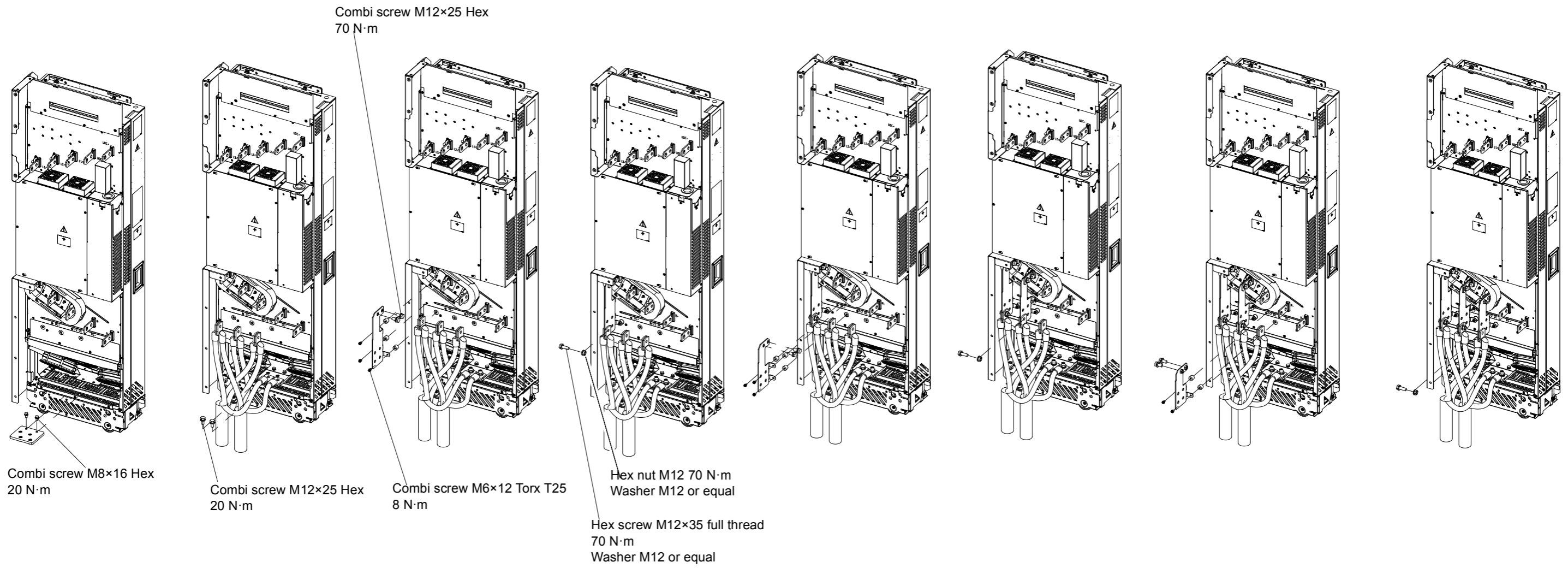

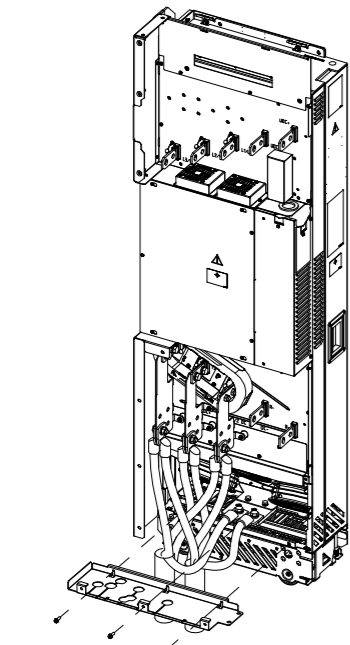

Combi screw M6×20
Torx T25 2 N·m

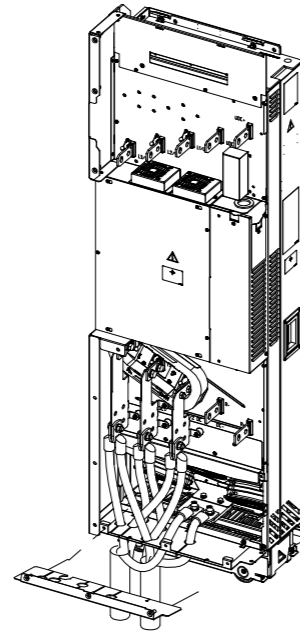

Combi screw M6×20
Torx T25 2 N·m

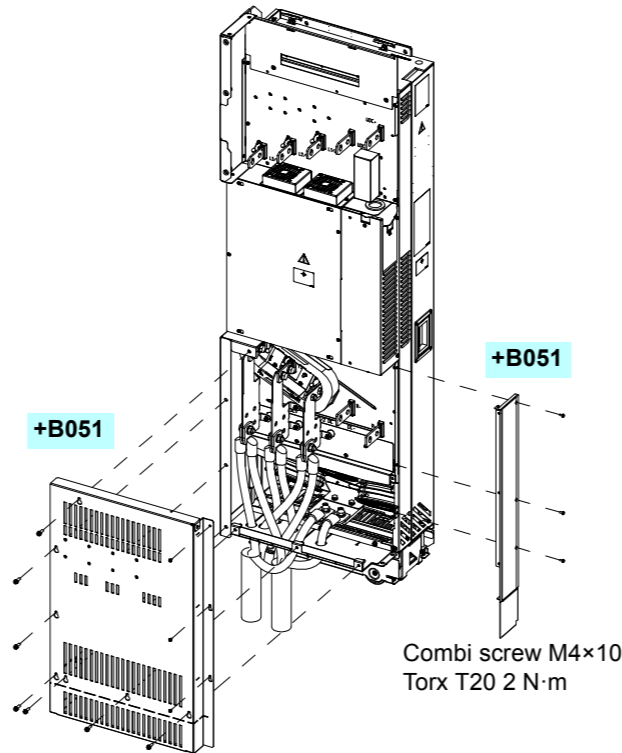

Combi screw M4×10
Torx T20 2 N·m

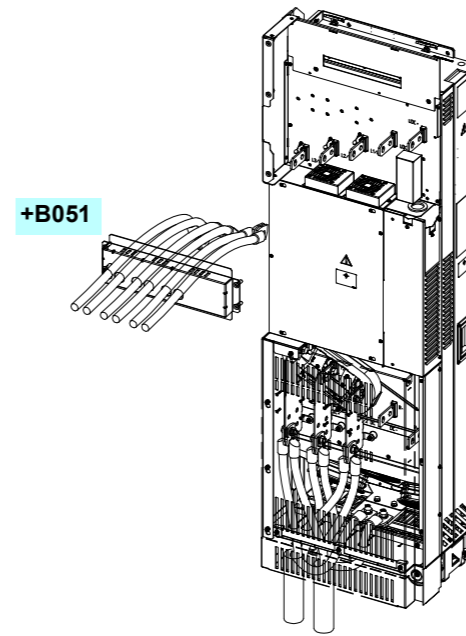

+B051

Hex screw M12×35 full thread
70 N·m
Washer M12 or equal

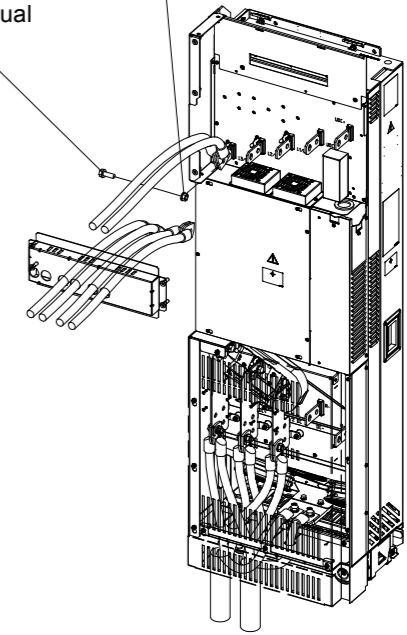

Hex nut M12 70 N·m
Washer M12 or equal

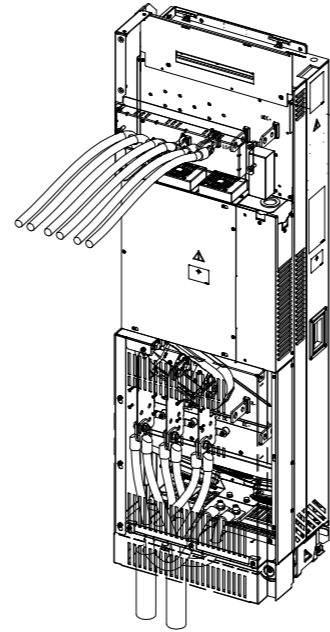
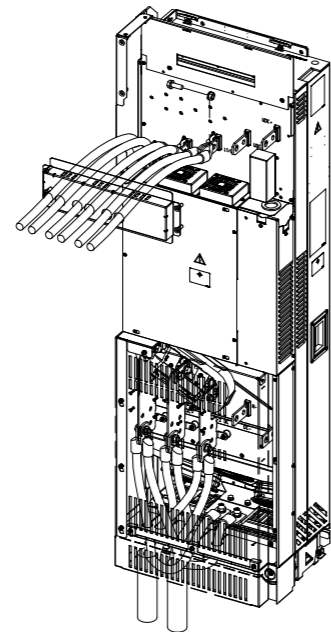
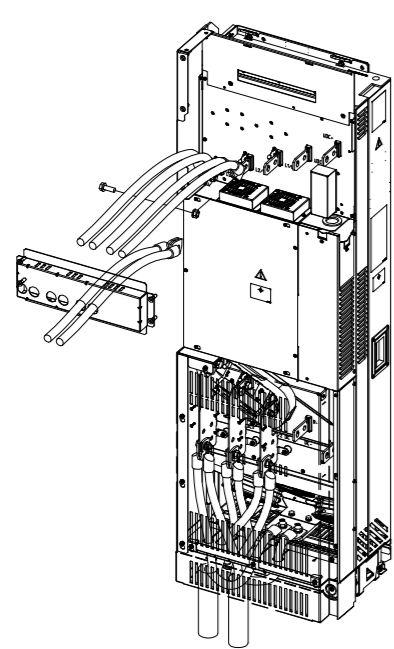

Combi screw M4×10
Torx T20 2 N·m

+B051

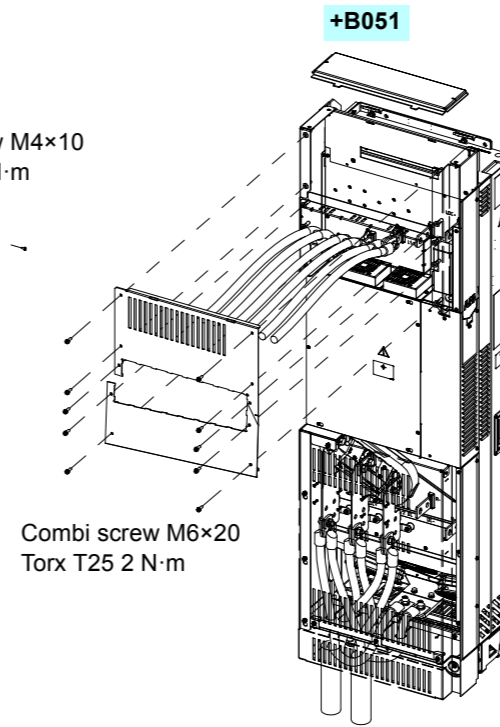

Combi screw M6×20
Torx T25 2 N·m

+B051

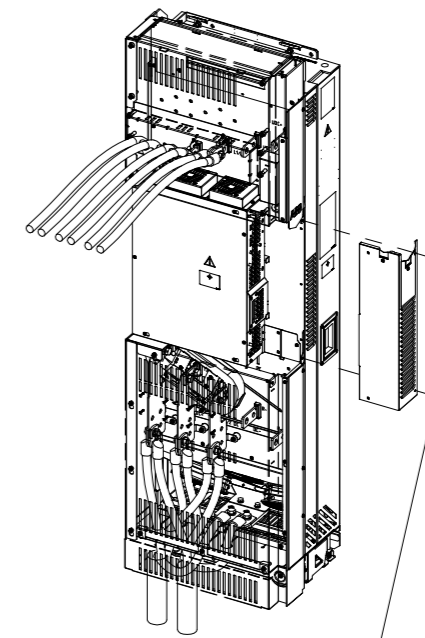

Combi screw M4×8 Torx T20
2 N·m

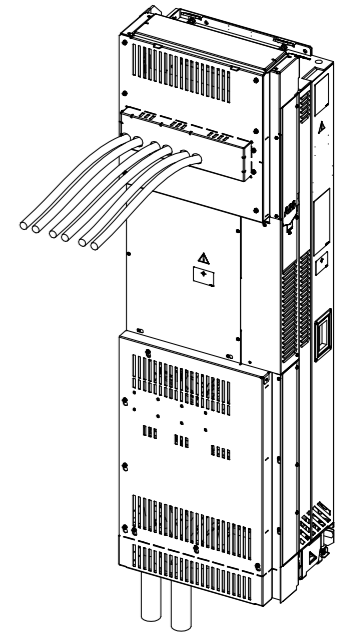

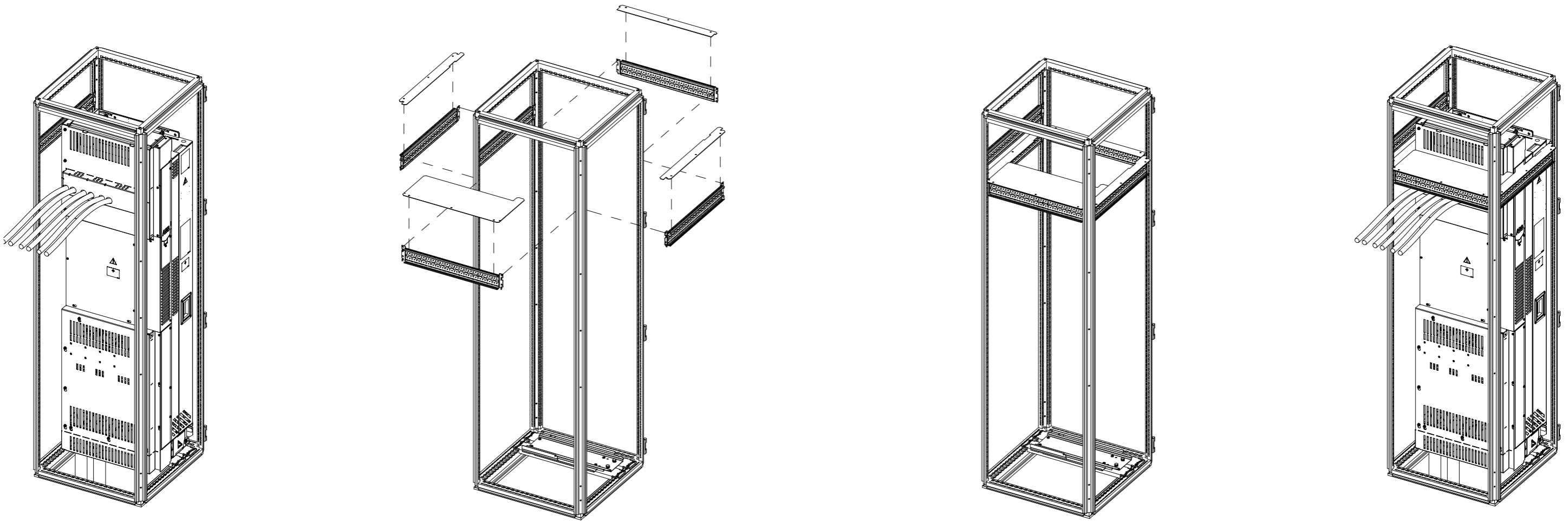

Note: These air baffles are compatible with option +B051 only, for the standard drive module configuration, see section [Standard drive module configuration](#) on page 46.

Further information

Product and service inquiries

Address any inquiries about the product to your local ABB representative, quoting the type designation and serial number of the unit in question. A listing of ABB sales, support and service contacts can be found by navigating to www.abb.com/searchchannels.

Product training

For information on ABB product training, navigate to new.abb.com/service/training.

Providing feedback on ABB manuals

Your comments on our manuals are welcome. Navigate to new.abb.com/drives/manuals-feedback-form.

Document library on the Internet

You can find manuals and other product documents in PDF format on the Internet at www.abb.com/drives/documents.

Contact us

www.abb.com/drives
www.abb.com/drivespartners

3AXD50000048685 Rev A (EN) 2017-05-12

