

## 4. Replacement of interface options

Optional modules such as fieldbus adapters and I/O extensions are inserted in the optional module slot on the control unit.

ACX580 CCU control unit contains three option slots. In the table below there is described which interface options can be used in which slot

Option modules	Install to
Fieldbus adapters (FENA, FPBA)	Slot 1
I/O extensions (CMOD)	Slot 2
Embedded fieldbus (CEIA)	Slot 3

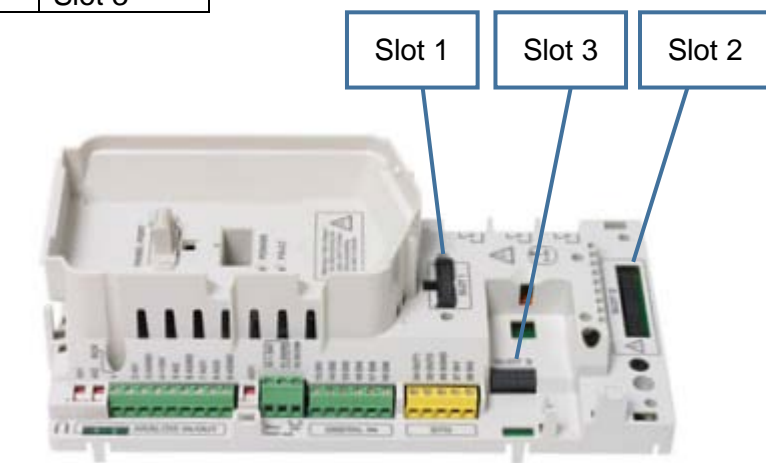
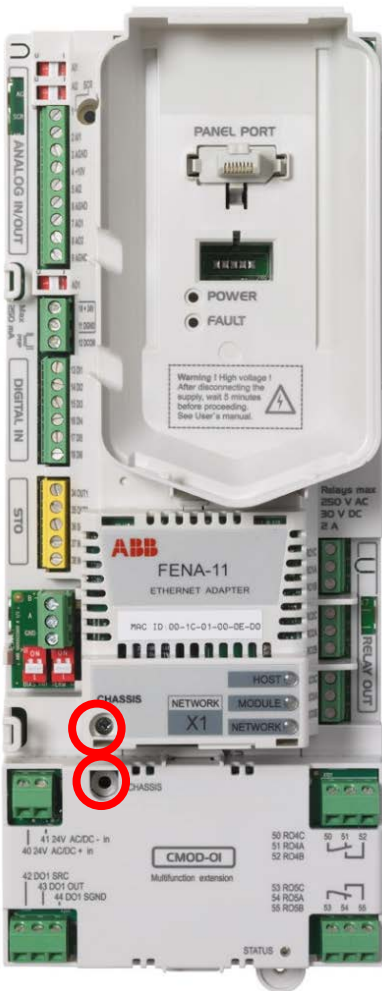

CCU-11 option slots

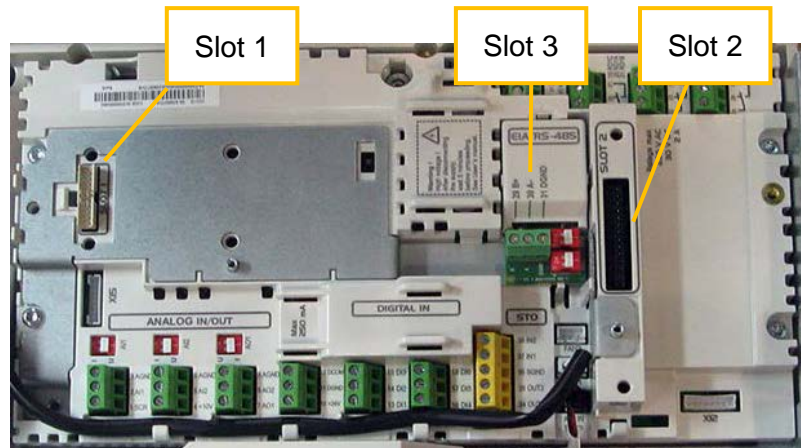

CCU-12 option slots

**Install the optional modules as follows:**

1. Insert the module carefully into its position on the control board.
2. Fasten the **fastening screws**. **Note:** Proper tightening of the screws is essential for fulfilling the EMC requirements and for proper operation of the module.