 ABB Oy, Drives Service		On-Site Service Instructions		Document nbr 3AXD10000303478
		ACx580-01 R6-R9		Related to material
Department ESP400	Date 30.05.2016	Revision B	Page 122 (126)	

4. Other maintenance actions

4.1 Replacement of interface options

Optional modules such as fieldbus adapters and I/O extensions are inserted in the optional module slot on the control unit.

ACS580 CCU control unit contains three option slots. In the table below there is described which interface options can be used in which slot

Option modules	Install to
Fieldbus adapters (FENA, FPBA)	Slot 1
I/O extensions (CMOD)	Slot 2
Embedded fieldbus (CEIA)	Slot 3

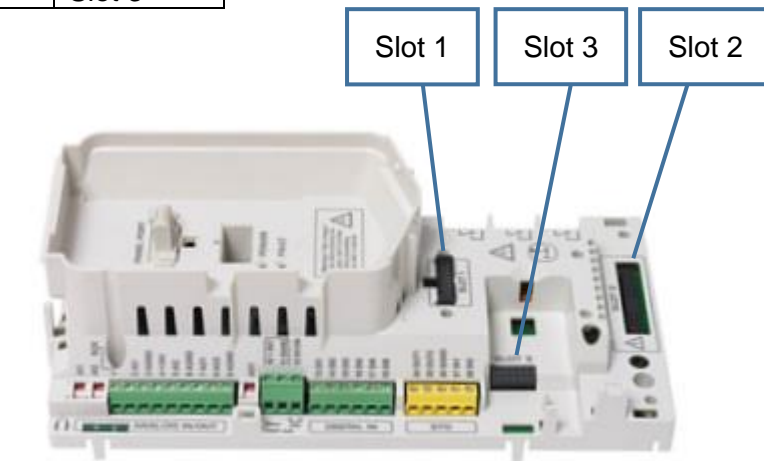

CCU-11 option slots

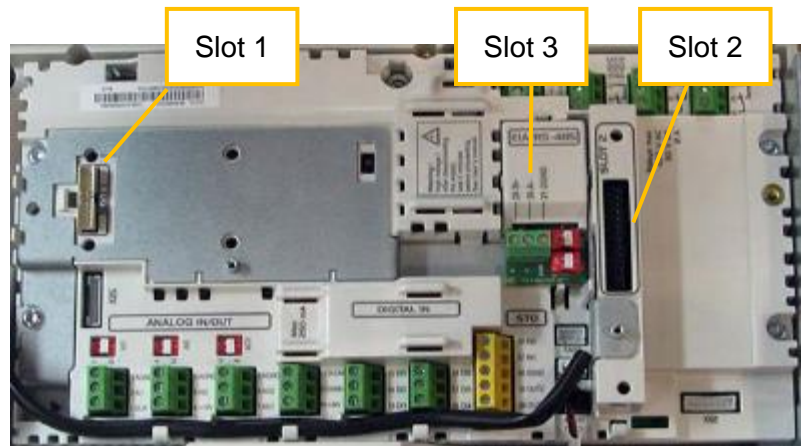

CCU-12 option slots

Install the optional modules as follows:

1. Insert the module carefully into its position on the control board.
2. Fasten the **fastening screws**. **Note:** Proper tightening of the screws is essential for fulfilling the EMC requirements and for proper operation of the module.